

Original citation:

Hadley, Mark J.. (1999) Topology change and context dependence. International Journal of Theoretical Physics, Volume 38 (number 5). pp. 1481-1492.

Permanent WRAP url:

<http://wrap.warwick.ac.uk/14412>

Copyright and reuse:

The Warwick Research Archive Portal (WRAP) makes this work of researchers of the University of Warwick available open access under the following conditions. Copyright © and all moral rights to the version of the paper presented here belong to the individual author(s) and/or other copyright owners. To the extent reasonable and practicable the material made available in WRAP has been checked for eligibility before being made available.

Copies of full items can be used for personal research or study, educational, or not-for-profit purposes without prior permission or charge. Provided that the authors, title and full bibliographic details are credited, a hyperlink and/or URL is given for the original metadata page and the content is not changed in any way.

Publisher statement:

The final publication is available at Springer via

<http://dx.doi.org/10.1023/A:1026697201033>

A note on versions:

The version presented here may differ from the published version or, version of record, if you wish to cite this item you are advised to consult the publisher's version. Please see the 'permanent WRAP url' above for details on accessing the published version and note that access may require a subscription.

For more information, please contact the WRAP Team at: publications@warwick.ac.uk

warwick**publications**wrap

highlight your research

<http://wrap.warwick.ac.uk/>

Topology change and context dependence

Mark J Hadley

Department of Physics, University of Warwick, Coventry CV4 7AL, UK

email: M.J.Hadley@warwick.ac.uk

Tel: +44 1203 522410

Fax: +44 1203 692016

Abstract

The non-classical features of quantum mechanics are reproduced using models constructed with a classical theory - general relativity. The inability to define complete initial data consistently and independently of future measurements, non-locality, and the non-Boolean logical structure are reproduced by these examples. The key feature of the models is the role of topology change. It is the breakdown of causal structure associated with topology change that leads to the apparently non-classical behaviour. For geons, topology change is required to describe the interaction of particles. It is therefore natural to regard topology change as an essential part of the measurement process. This leads to models in which the measurement imposes additional non-redundant boundary conditions. The initial state cannot be described independently of the measurement and there is a causal connection between the measurement and the initial state.

Key Words

Topology change, Closed timelike curves, Quantum mechanics

1 Introduction

It is well known that quantum mechanical systems cannot be described as classical systems evolving in time independently of future measurements (Belinfante 1973, Beltrametti & Cassinelli 1981). Attempts to construct classical models either fail or have non-local, measurement-dependent, influences. The Kochen-Specker paradox (Belinfante 1973) is an example of the inability to assign initial data (particle spins) independently of future measurements. While in Bohm's theory particle positions and momenta can be defined but they are insufficient to determine the subsequent evolution - the desired results are only obtained at the expense of introducing a non-local influence in the form of the pilot wave.

Common to any interpretation of quantum mechanics is the non-Boolean logical structure (Isham 1968, Beltrametti & Cassinelli 1981) of the propositions. The propositions have to be defined differently in the different interpretations (see (Isham 1968, Section 9.2)), so that in some interpretations the propositions are about properties held by the particle while in other interpretations this would be meaningless and the propositions are statements about the state preparation. The non-Boolean logic of propositions characterises quantum theory and distinguishes it from classical theory. Once a measurement is defined, and propositions are restricted to those that relate to the chosen measurement apparatus, the results have the familiar logical structure - that this must be the case is explained by Mackey see (Belinfante 1973, Beltrametti & Cassinelli 1981, Chapter 13). Unlike any classical theory, quantum mechanics is therefore a context-dependent theory.

It is known that if a breakdown in causal structure is an inherent feature of elementary particles then the propositions associated with the theory could have the, non-Boolean, logical structure of quantum mechanics (Hadley 1997). In this paper models are constructed upon which it is impossible to define complete initial data independently of future measurements. This context dependence is the essence of the Kochen-Specker Paradox. Another striking characteristic of quantum theory is the non-locality predicted, and confirmed, in EPR experiments - this too is reproduced in these examples.

As early as 1957 Dennis Sciama pointed out that quantum mechanics was a way to account for hidden variables where half of them were in the future (Sciama 1957)

A common feature of the models presented in this paper, is a breakdown of the causal structure in such a way that there exists a causal link from the measurement to the *initial* data, and that the measurement itself imposes non-redundant boundary conditions. It is known that a theory with these properties will have the logical

structure of quantum mechanics. Apart from exotic alternatives (Fivel 1994), any vector representation will have the familiar Hilbert space structure, operators and commutation relations.

Models of elementary particles based on geons (where some or all of the particle's properties arise from the topology of spacetime) require topology change to occur when interactions take place. Theorems of Geroch and Tipler place severe constraints on topology change which prevent it occurring without a breakdown of the causal structure in one sense or another. The relationship between topology change and non-trivial causal structure is exploited in this paper. By associating topology change with the measurement process in quantum mechanics, we are naturally led to models which display context dependence.

Geroch's theorem (Geroch 1967) shows that for a compact time-oriented manifold without closed timelike curves, CTCs, the topology cannot change from one spacelike boundary to the other. Some authors consider the causal structure to be more fundamental and have examined spacetimes with singularities in order to allow topology change (Dowker & Garcia 1997, Sorkin 1997). This paper does not consider singularities, it retains the framework of classical general relativity - including a continuous spacetime manifold with a continuous metric. The breakdown in causal structure is actually seen as advantageous because it offers a way of reconciling classical and quantum physics (Hadley 1997). The examples are created by relaxing the assumptions of Geroch's theorem. We consider in turn manifolds which are not time-orientable, those with CTCs, non-compact manifolds and finally examples where the spacelike boundaries cannot be defined. In each case the properties are compared with the phenomena previously associated exclusively with quantum theories. If topology change is considered to be an integral part of the measurement process then these models are examples of context dependence which is the distinguishing characteristic of quantum theory.

2 Notation

The paper is concerned with spacetime manifolds of 1+1, 2+1 and 3+1 dimensions with a Lorentzian metric of signature $(-,+)$, $(-,+,+)$ and $(-,+,+,+)$ respectively. The combination of the manifold and the Lorentzian metric is referred to as a **geometry**. The metric defines a timelike ray (a pair of timelike vectors γ and $-\gamma$ corresponding to a forward and backward direction in time). A geometry which is time-orientable admits a continuous choice of timelike vector γ and is called **isochronous**. An isochronous manifold M therefore admits a continu-

ous vector field. Indeed a manifold which admits a continuous vector field can be endowed with a Lorentzian metric such that it is isochronous see for example (Borde 1997, Reinhart 1963).

The constructions which follow comprise a geometry M (of dimension $n + 1$) whose boundary is the disjoint union of two manifolds Σ_1 and Σ_2 (each of dimension n). By a topology change we mean that the topology of Σ_1 differs from that of Σ_2 . From the results above, a timelike vector field can be constructed in the isochronous case. A unique timelike curve can be constructed through any point such that the curve is everywhere tangent to the vector field. The curves, but not the vector field, can also be constructed in a geometry which is not isochronous.

Most of the paper is concerned with compact geometries. An important class of non-compact spacetimes to which Geroch's theorem, and related considerations, also apply are externally simple spacetimes (see Borde (Borde 1997)). A spacetime M is externally simple if there exist compact regions $\tilde{\Sigma}_1$ and $\tilde{\Sigma}_2$ such that $\Sigma_1 - \tilde{\Sigma}_1$ is diffeomorphic to $\Sigma_2 - \tilde{\Sigma}_2$.

3 Theorems

The following theorem, attributed to C W Misner, is a result special to $3 + 1$ dimensions:

Theorem 1 (Misner) *Let Σ_1 and Σ_2 be two compact 3 manifolds. Then there exists a compact geometry M whose boundary is the disjoint union of Σ_1 and Σ_2 , and in which Σ_1 and Σ_2 are both spacelike.*

A proof can be found in (Geroch 1967, Yodzis 1972). The significance of the theorem is that, in the three space and one time dimension of primary interest, a timelike vector field can always be constructed. There are no topological obstructions as there are in other dimensions.

Theorem 2 (Geroch) *Let M be a compact 4-manifold with metric signature $(-, +, +, +)$ whose boundary is the disjoint union of two compact spacelike manifolds, Σ_1 and Σ_2 . Suppose M is isochronous and has no closed timelike curves (CTCs). then Σ_1 and Σ_2 are diffeomorphic and further, M is topologically $\Sigma_1 \times [0, 1]$.*

Although a 4-manifold was specified (three space and one time dimension) in the original theorem, the proof is also valid for 1+1 and 2+1 dimensions.

Essentially, in order for topology change to take place, from one spacelike boundary to another, at least one timelike ray must pass through Σ_1 but not Σ_2 or vice versa. Geroch shows that for compact manifolds there are only two ways for this to happen:

1. The timelike rays that cross the surface Σ_1 and enter M , never leave the interior of M - in which case, due to the assumed compactness, there must be a CTC within M .
2. The timelike rays that cross the surface Σ_1 and enter M , also exit through Σ_1 - which implies that M cannot be isochronous.

The first case is further refined by Tipler, who assumes that M is isochronous:

Theorem 3 (Tipler) *Topology change cannot occur on an isochronous 4-geometry which satisfies Einstein's equations and the weak energy condition.*

Note that Einstein's equations, by themselves, place no constraint whatsoever on the topology (or even the metric). It is only the combination of the equations with some assumptions about physically realistic energy momentum tensors that places a kinematic constraint.

4 Manifolds which are not isochronous

When time-orientability is not required, some timelike curves from Σ_1 can enter the manifold and exit through Σ_1 rather than Σ_2 . A simple example is $S^1 \rightarrow \emptyset$, as depicted in figure 1, formed from the cylinder $S^1 \otimes I$, where I is an interval $[0, \tau]$. The first spacelike surface, Σ_1 , is S^1 ; in place of the second surface we identify antipodal points to create a möbius band oriented in the space direction but not the time direction. Every timelike curve from Σ_1 (S^1) which enters M re-emerges through Σ_1 after a finite time.

Initial data on Σ_1 cannot be defined without knowing the value of τ (the time at which the antipodal map occurs). Consider, for example, a wave $\psi(\theta, t)$ which satisfies the one dimensional wave equation. The general solution $\psi(\theta, t) = \zeta(\theta - vt) + \phi(\theta + vt)$ (with ζ and ϕ having period 2π) is subject to additional constraints - consistency requires: $\psi(\theta, t) = \zeta(\theta - vt) + \zeta(\theta + vt - 2v\tau + \pi)$, which depends upon the value of τ .

Clearly the example can be extended to any number of disconnected spaces $n \times S^1 \rightarrow m \times S^1$. The model has been described as the annihilation of a universe (Borde 1997). The main purpose of this paper is to consider kinematics rather than dynamics, however, this particular example is flat - and hence trivially satisfies Einstein's equations in 1+1 dimensions. The model can also be extended to higher dimensions. In 2 + 1 dimensions the space orientation is also reversed by the antipodal map. In 3+1 dimensions we have $S^3 \rightarrow \emptyset$ which satisfies Einstein's equations with a non-zero cosmological constant (it is an Einstein cylinder with the antipodal map imposed). The constraints on initial data in the 3+1 case can be demonstrated by considering gravitational waves following null geodesics rather than an unspecified extraneous wave - in which case the manifold is the combination of an underlying slowly varying spacetime and a smaller scale ripple.

If the topology change is associated with a measurement, then the measurements at two different times, corresponding to a topology change at $t = \tau_1$ or at $t = \tau_2$, would be incompatible. The topology change cannot take place at both values of τ , and the alternative times would impose different boundary conditions on the problem. To illustrate the non-Boolean logic; we consider either an unspecified one dimensional wave, a classical object like a billiard ball or (in 3+1 dimensions) a gravitational wave that is an intrinsic part of the manifold. In either case, the initial conditions must include a combination of a forward and backward moving wave (or particle); and the combination depends upon the value of τ .

Consider a version of the two slit experiment; with slits S_1 and S_2 and a measurement at $t = \tau$ to determine if a billiard ball is in the region $X = [x_1, x_2]$. As described above we associate a topology change and time reversal with the measurement process. The experiment can be carried out with either S_1 or S_2 or both slits open.

With the arrangement of figure 2(a) with only slit S_1 open, there are no trajectories consistent with a measurement at $t = \tau$. Similarly for the case with only S_2 open. With both S_1 and S_2 open, there is now a range of trajectories consistent with a measurement at $t = \tau$ and detection at X - one of which is shown by the dashed line in Figure 2(b).

These examples show that the probability of going through S_1 and reaching X is zero as is the probability of going through S_2 and reaching X, but the probability of going through (S_1 or S_2) and reaching X is not zero. This is a clear example of non-Boolean logic.

In a technical sense the objectives of this paper have been satisfied by this simple, and well-known, example of a geometry which exhibits a type of context sensitivity. Initial data cannot be specified independently of the topology change;

and there is a clear causal path from the measurement (antipodal map) to the *initial* surface. The parameter τ must be specified before the geometry can be defined.

Unfortunately, continuity prevents this construction being extended to more realistic examples such as a connected boundary Σ_1 changing to a non-empty boundary Σ_2 with a different topology. It is not therefore suitable as a model of particles interacting *within* a universe.

5 Spacetimes with closed timelike curves

Considering compact isochronous geometries, topology change can occur if CTC's are present in the interior of M . Some (or all) curves from the initial surface Σ_1 have no endpoint, they are trapped near a timelike curve. The final surface Σ_2 has some curves which originated in Σ_1 and others that have no past endpoints because they originated from the region of a CTC. There is no limit on topology change in 4 dimensions if CTCs are allowed (Geroch 1967).

Trivial examples of topology change with CTCs are known (Borde 1997, Dowker & Garcia 1997); in which either the initial or final surface is empty - (see for example figure 3). There are also examples with no timelike curve from the initial to final surface, because they are all confined to the interior of M . In this case Σ_2 cannot be considered to be in the future of Σ_1 . These cases will not be considered further because of the lack of any causal connection between the two boundaries.

The examples of interest are those where curves from a subset $A \subset \Sigma_1$ have an endpoint in $B \subset \Sigma_2$ while others are trapped within M . Since Σ_2 is compact there must be at least one point, p , of Σ_2 which is not in B . The curve through p cannot have a past endpoint in M and must therefore originate from the region of a CTC.

These geometries do not exhibit quantum phenomena. The topology change introduces unknown (and probably unknowable) boundary conditions because some timelike curves do not originate in the initial surface. However, the topology change places no constraint on the initial data; there is no causal link from the measurement to the initial state nor any clear mechanism for non-local effects between separated measurements, as seen in quantum mechanics.

Although there is no dynamical constraint on the formation of CTCs, Tipler's theorem shows that Einstein's equations, plus the weak energy condition, prevents this mechanism for topology change.

6 Non-compact spacetimes

Geroch's theorem can be applied to externally simple geometries, even when they are not compact, because the topology change takes place in a compact region. An externally simple spacetime would be an appropriate description for a geon embedded in \mathbb{R}^4 . However, continuity still prevents a failure of time-orientability from being a mechanism for topology change.

More generally topology change can take place in non-compact geometries (Krasnikov 1995), because the timelike curves from Σ_1 can avoid the boundaries without being trapped near a closed timelike curve - see for example figure 4. These counter-examples can have topology change without a breakdown of the causal structure.

7 Non-spacelike boundaries

A further relaxation of the assumptions in Geroch's theorem, is to have boundaries (one or both) that are not entirely spacelike. The terms *initial* and *final* for the boundaries are not strictly correct although the majority of the surface could be spacelike. With such a significant departure from the conditions of Geroch's theorem, topology change is easily demonstrated. Figures 5 and 6 show a topology change from $S^1 \rightarrow S^1 \cup S^1$, both examples are not time-orientable. Figure 5 has an initial spacelike boundary, but the final boundaries are not spacelike. Figure 6 does not have either an initial or final spacelike boundary but it is clearly flat, and therefore a trivial solution to the field equations. Another feature of figure 6 is the causal link between the two *legs* of the trousers, which has some comparisons with an EPR experiment. A more realistic model of an EPR experiment would be a combination of three topology changing regions corresponding to the pair creation, and measurement in the two arms of the experiment.

An externally simple example is shown in figure 7 which illustrates $\mathbb{R} \rightarrow \mathbb{R} \cup S^1$: the manifold is not isochronous. The mechanism for topology change is essentially that of the non-isochronous case (section 4 above), the freedom to allow non-spacelike surfaces, permits the construction of non-trivial examples with a continuous metric. In the examples of figures 5 and 7, the initial surface Σ_1 is spacelike and time *can* be oriented in a finite neighbourhood of Σ_1 . It is the subsequent topology change that turns some timelike geodesics back to Σ_1 and obstructs the time-orientability of the geometry.

8 Conclusion

In these examples, boundary conditions cannot be specified on the initial surface without knowing about the subsequent measurement (topology change). There is a causal link between the measurement and the initial surface. This breakdown of the causal structure, associated with a measurement, will necessarily require a context dependent theory such as quantum theory to describe the observations.

All these compact and externally simple examples prevent, or at least limit, the construction of spacelike boundaries and spacelike hypersurfaces. It must be stressed that this does not indicate any departure from the equations or structure of classical general relativity. To require spacelike boundaries is an extra, convenient but unwarranted, constraint commonly imposed upon the theory. It is a constraint that is not justified either by the mathematical structure or by physical reality. Indeed, what we know about quantum theory is incompatible with spacetime being a classical hypersurface evolving with time. Quantum theory gives evidence for the small scale structure of spacetime and general relativity could, in return, explain the origins of quantum phenomena.

Of all the interpretations of quantum mechanics, this work relates closely to the pragmatic interpretation of quantum mechanics, where the wavefunction is simply a way of determining the probabilities of the different outcomes from an experiment.

Consider the classical case, $P(n) = 1/6$; ($n = 1, 2 \dots 6$) is a probability function which gives the result of a dice throw; but there is no direct relationship between $P(n)$ and the underlying Newtonian laws of motion. Indeed the probability function does not depend upon the exact form of the equations of motion, it depends only upon the structural form and the symmetry. The classical equations can be expressed as deterministic equations with uniquely defined trajectories determined by the initial conditions alone. The sets of initial conditions corresponding to different results satisfy a Boolean algebra. In principle a measure on the space of initial conditions can be used to calculate the probability function, $P(n)$. The equations of motion are independent of n - this gives the essential symmetry.

With the measurement dependent effects shown here, general relativity gives a different structure. A measure over *initial* conditions and measurement conditions would also give a Boolean logic as required by Mackey (Mackey 1963); but a measure over *initial* conditions alone would give a different logical structure which must be orthomodular (Hadley 1997, Beltrametti & Cassinelli 1981). The orthomodular structure can be represented by the projections on a Hilbert Space (Beltrametti & Cassinelli 1981). Given the Hilbert Space structure, it is well-

known that the equations for the wavefunction can be derived from symmetry arguments(Ballentine 1989, Weinberg 1995). As in the classical case, the probability function does not depend upon the details of the equations of motion; just on their form.

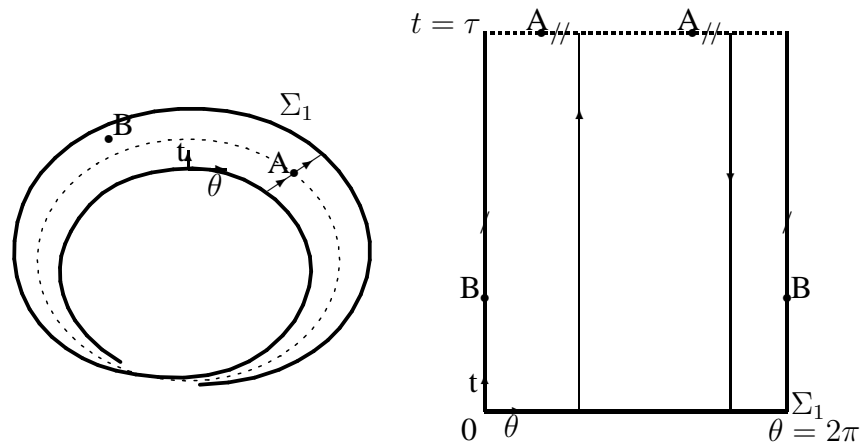

Figure 1: Topology change from $S^1 \rightarrow \emptyset$ to create a manifold that is not isochronous. Depicted pictorially and diagrammatically as a rectangle with sides identified. Every timelike curve originating in Σ_1 returns to Σ_1

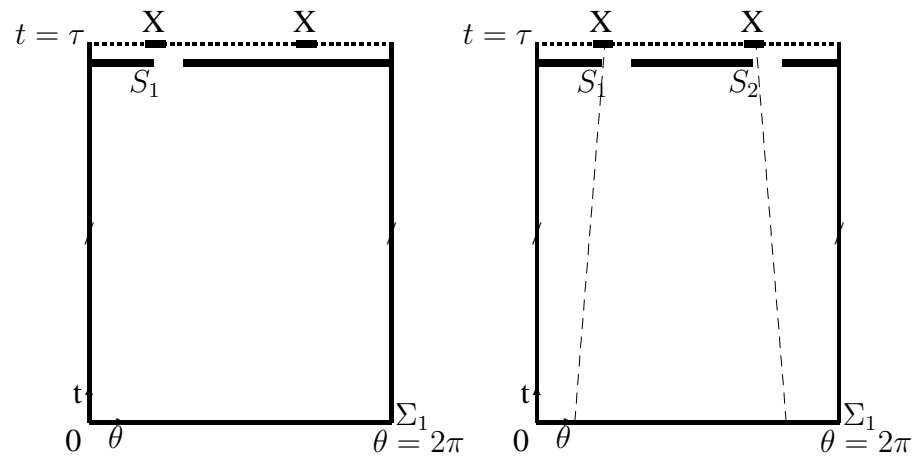

Figure 2: A Two slit experiment: a) there are no trajectories consistent with only slit 1 or slit 2 being open, b) there are consistent trajectories (dashed line) when both slits are open.

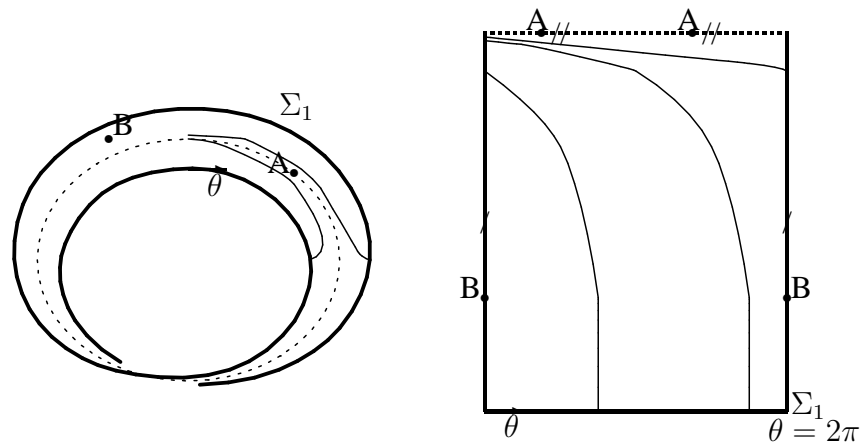

Figure 3: Topology change $S^1 \rightarrow \emptyset$ on a manifold with CTCs. The timelike curves form Σ_1 enter the manifold and never exit. They asymptotically approach the CTC (dashed line).

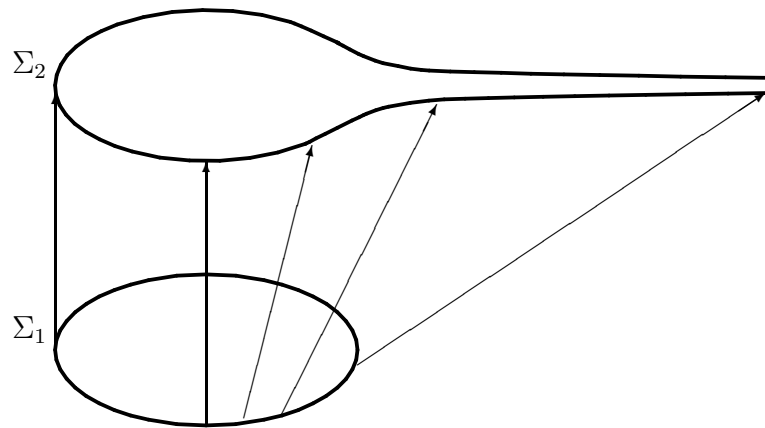

Figure 4: Topology change $S^1 \rightarrow \mathbb{R}$ on a manifold that is not compact. There is no breakdown of the causal structure.

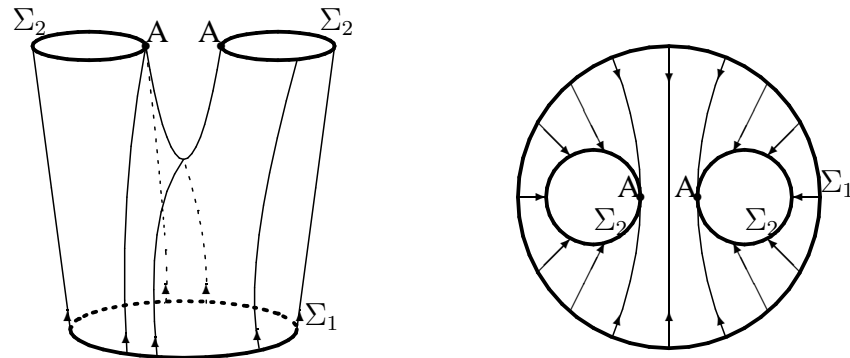

Figure 5: Topology change from $S^1 \rightarrow S^1 \cup S^1$. Σ_1 is spacelike but some timelike curves from Σ_1 return to Σ_1 . The surface Σ_2 is not entirely spacelike. At points A the timelike curves are tangent to Σ_2 .

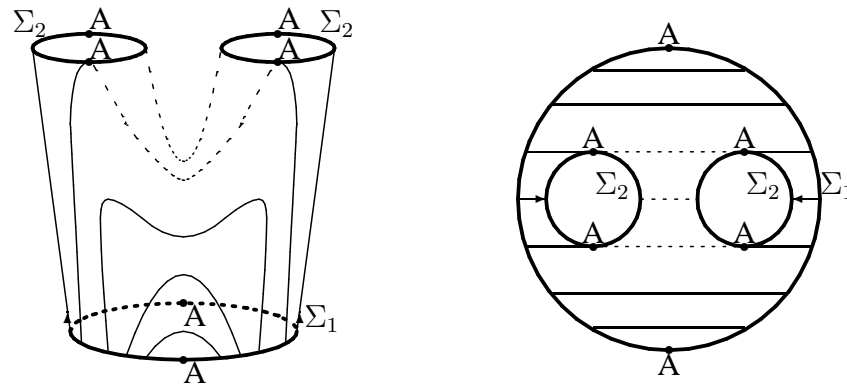

Figure 6: Topology change from $S^1 \rightarrow S^1 \cup S^1$. The manifold is flat but neither Σ_1 nor Σ_2 is entirely spacelike. At points A the timelike curves are tangent to the surfaces. Note the timelike curves (dashed curves) joining the different legs of the trousers.

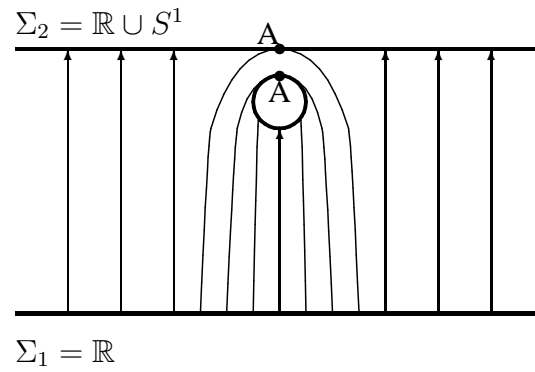

Figure 7: Topology change from $\mathbb{R} \rightarrow S^1 \cup \mathbb{R}$. Σ_1 is spacelike but some timelike curves from Σ_1 return to Σ_1 . The surface Σ_2 is not entirely spacelike. At points A the timelike curves are tangent to Σ_2 .

References

- Ballentine, L. E. (1989), *Quantum Mechanics*, Prentice Hall.
- Belinfante, F. J. (1973), *A Survey of Hidden-Variables Theories*, Pergamon Press.
- Beltrametti, E. G. & Cassinelli, G. (1981), *The Logic of Quantum Mechanics*, Vol. 15 of *Encyclopedia of Mathematics and its Applications*, Addison-Wesley Publishing Company.
- Borde, A. (1997), 'How impossible is topology change?', *Bull. Astr.Soc. India (eprint gr-qc/9406053)* **25**, 571–577.
- Dowker, H. F. & Garcia, R. S. (1997), 'A handlebody calculus for topology change', gr-qc/9711042.
- Fivel, D. I. (1994), 'How interference effects in mixtures determine the rules of quantum mechanics', *Physical Review A* **50**(3), 2108–2119.
- Geroch, R. P. (1967), 'Topology in general relativity', *Journal of Mathematical Physics* **8**, 782–786.
- Hadley, M. J. (1997), 'The logic of quantum mechanics derived from classical general relativity', *Foundations of Physics Letters* (eprint quant-ph/9706018) **10**(1), 43–60.
- Isham, C. J. (1968), *Quantum Theory- Mathematical and Structural Foundations*, Imperial College Press.
- Krasnikov, S. V. (1995), 'Topology change without pathology', *General Relativity and Gravitation* **27**(5), 529–536.
- Mackey, G. W. (1963), *The Mathematical Foundations of Quantum Mechanics*, W A Benjamin Inc.
- Reinhart, B. L. (1963), 'Cobordism and the euler number', *Topology* **2**, 173–177.
- Sciama, D. W. (1957), Determinism and the cosmos, in S. Hook, ed., 'Determinism and Freedom in the Age of Modern Science', Collier-Macmillan.
- Sorkin, R. D. (1997), 'Forks in the road, on the way to quantum gravity', gr-qc/9706002.

Weinberg, S. (1995), *The quantum theory of fields*, Cambridge University Press.

Yodzis, P. (1972), 'Lorentz cobordism', *Communications in Mathematical Physics* **26**, 39–52.