

University of Warwick institutional repository: <http://go.warwick.ac.uk/wrap>

This paper is made available online in accordance with publisher policies. Please scroll down to view the document itself. Please refer to the repository record for this item and our policy information available from the repository home page for further information.

To see the final version of this paper please visit the publisher's website. Access to the published version may require a subscription.

Author(s): Robert E. Critoph, Steven J. Metcalf and Zacharie Tamainot-Telto

Article Title: Proof of Concept Car Adsorption Air Conditioning System Using a Compact Sorption Reactor

Year of publication: 2010

Link to published article:

<http://dx.doi.org/10.1080/01457631003604459>

Publisher statement: 'This is an electronic version of an article published in Critoph, R. E. (2010). Proof of Concept Car Adsorption Air Conditioning System Using a Compact Sorption Reactor. Heat Transfer Engineering, Vol. 31(11), pp. 950 – 956. Heat Transfer Engineering is available online at:

<http://www.informaworld.com/smpp/content~content=a918860045>

**Proof of Concept Car Adsorption Air Conditioning System Using a Compact Sorption
Reactor**

Robert E. Critoph, Steven J. Metcalf, Zacharie Tamainot-Telto

School of Engineering, University of Warwick, UK.

Address correspondence to: R.E Critoph, School of Engineering, University of Warwick,
CV4 7AL, UK. Tel. +44 2476 523137, Fax +44 2476 418922, e-mail
R.E.Critoph@warwick.ac.uk

ABSTRACT

A prototype compact sorption generator using an activated-carbon ammonia pair based on a plate heat exchanger concept has been designed and built at Warwick University. The novel generator has low thermal mass and good heat transfer. The heat exchanger uses Nickel brazed shims and spacers to create adsorbent layers only 4 mm thick between pairs of liquid flow channels of very low thermal mass. The prototype sorption generator manufactured has been evaluated under the EU car air conditioning testing conditions.

While driven with waste heat from the engine coolant water (at 90°C), a pair of the current prototype generators (loaded with about 1 kg of a carbon in each of two beds) has produced an average cooling power of 1.6 kW with 2 kW peaks.

INTRODUCTION

Adsorption refrigeration and heat pumping devices have the potential to reduce harmful and greenhouse gas emissions (CO, CO₂, NO_x, SO_x ...) and to produce substantial fuel savings. The primary energy source for state of the art Mobile Air Conditioning (MAC) systems in cars is mechanical power produced by the engine, to drive the compressor, and electric power to run the fans, which in turn is again derived from the mechanical power from the engine itself. The air conditioning system has a considerable impact on fuel consumption. For a B class car on an urban cycle under severe ambient conditions (35°C and 60% RH) it can increase car fuel consumption by up to 70% [1]. The CO₂ emissions due to the use of MAC ranges from 4 to 8% on a yearly basis. This is equivalent to CO₂ emissions from 5 to 10 Million tons of CO₂ per year in Europe and correspondingly more globally [1].

The major technical challenges to developing a sorption system to use the waste heat of a car engine are:

1. Reducing the size sufficiently to fit within the required space,

2. To obtain a sufficient Coefficient of Performance (COP) to deliver adequate cooling to the vehicle under all driving conditions.

The intensification of heat transfer within sorption generators has been the focal point of adsorption refrigeration R&D at Warwick University, aimed at high power density and COP for both cooling and heating systems. The concept of a plate heat exchanger (PLATEX) applied to sorption generators (adsorber/desorbers) for cooling and heat pump applications has been investigated and has proven to be interesting. Initial computational modelling of a compact generator using the carbon-ammonia pair reveals an attractive performance: specific cooling power (SCP, the cooling power per unit mass of adsorbent) from 1 kW kg⁻¹ carbon up to 6.5 kW kg⁻¹ carbon; specific heating power 0.250 kW kg⁻¹ carbon up to 2.5 kW kg⁻¹ carbon with cooling COP varying between 0.5 and 1.2 [2,3].

In the EU-TOPMACS (Thermally OPerated Mobile Air Conditioning System) project, co-ordinated by Centro Recherche Fiat, a system is being designed for a Class C passenger vehicle. Table 1 shows the required cooling power for 'Normal' use, i.e. transient urban driving cycle use. This is actually the most demanding condition for a waste heat driven system, because the quantity of waste heat can be limiting. Analysis of the heat available from the car's exhaust and cooling water in both urban and highway driving conditions reveals firstly that the heat recoverable from the exhaust is too variable and is insufficient to drive a sorption system under urban driving cycles and secondly that there will probably be extreme conditions when either storage (of cold or heat) or a backup heat source for the sorption chiller will be needed. The chosen solution is to rely on a backup heater using the vehicle's fuel which is diesel oil. Provided the auxiliary heat is only needed infrequently there will still be considerable fuel savings. The 80°C driving temperature corresponds to waste heat operation solely and the 90°C to waste heat boosted by auxiliary heat.

In 'Extreme' conditions (motorway driving at an ambient temperature of 38°C) heat is available at 90°C and a COP of 0.24 is required. This is easily achievable with the system described below and we will concentrate on performance under the more onerous 'Normal' conditions.

There is also a 'cooldown' test condition: water inlet to condenser and adsorber 48°C, evaporating temperature 20°C, cooling power 4kW. This corresponds to starting the system after the car has been left for a long time in a hot environment.

A further requirement is that the total system volume should be less than 16 litres and mass less than 35 kg.

SYSTEM DESIGN

It is well known that for all sorption systems there is a trade-off between the internal thermal regeneration employed (and hence efficiency) and the power density that can be obtained (and hence physical size for a required cooling capacity). In the case of car air conditioning with a driving temperature of no more than 95°C and ambient temperature that could have a typical value of 30°C there is very little gain to be had from complex many-bed configurations, and a simple two-bed system with mass recovery was selected. Figure 1 is a system schematic. Valves V1-V4 may be set so that hot water from the engine cooling jacket passes through Generator (adsorber/desorber) G1 whilst water from a fan coil cools Generator (adsorber/desorber) G2 towards ambient, or vice versa. Operation is straightforward:

1. Generator (adsorber/desorber) G1 is heated by water from the engine cooling circuit, desorbing ammonia which flows through the check-valve V6 to the condenser, where it condenses, rejecting heat to ambient air and then through the refrigerant expansion valve (throttle) V5 to the evaporator where it boils and chills the water-glycol mixture that cools the vehicle cabin. The low-pressure ammonia gas passes through check

valve V8 to G2 where it is adsorbed. The heat of adsorption is removed by pumped water that is circulated through an air cooled heat exchanger via pump P2 and valves V3,V4.

2. External heating and cooling of the beds stops whilst valve V10 is briefly opened for mass recovery. This allows a rapid transfer of ammonia from G2 to G1 as the pressures equalise. The effectively adiabatic desorption from the hot, previously high pressure bed results in a further reduction in concentration and a corresponding increase of the concentration of the cold previously low pressure bed. The increased concentration swing over the whole cycle results in both higher cooling power and COP.
3. Now G2 is heated to desorb ammonia and G1 cooled to adsorb ammonia as in phase 1 but with G1 and G2 interchanged. Ammonia flows from G2 through V9, condenser, expansion valve V5, evaporator, check valve V7 to G1.
4. Mass recovery as '2'.

The whole process then repeats as above.

The most novel parts of the system are the two sorption generators. The strict limitations on volume require a very compact solution. The generators are similar to plate heat exchangers but with the added constraint that their thermal mass must be as low as possible. Computer modelling implies that the conduction path through the carbon (typical conductivity of the order of $0.1 \text{ W m}^{-1} \text{ K}^{-1}$) should not be more than about 2 mm to ensure low cycle times and adequate SCP's. The water-side heat transfer is by means of nominal 0.5 mm square channels with 1 mm pitch. Laminar flow in such small channels ensures good heat transfer. Taking an approximate Nusselt number of 3 (typical of the three standard boundary conditions of uniform heat flux in flow direction and uniform wall temperature at

particular flow cross section, uniform heat flux both in flow direction and around periphery, and uniform wall temperature, from Holman [4]) the water side heat transfer coefficient based on the projected area of the plate is approximately $3800 \text{ W m}^{-2} \text{ K}^{-1}$. The heat flux per unit temperature difference (UA in W K^{-1}) value for fluid heat transfer has been calculated at 4200 W K^{-1} . The plates with their water channels were fabricated from pairs of stainless steel shims. 0.65 mm thick shims, approximately 150 mm x 150 mm were chemically etched to create 'D' shaped channels (Figure 2) which approximated to 0.5 mm square cross section. When brazed to 0.25 mm thick plain shims the pairs form the required water flow channels. Between each of the shim pairs a 4 mm thick U-shaped spacer contains the carbon adsorbent. A total of 28 shim pairs, 29 spacers and 2 end plates are nickel brazed in one operation to form the core of the adsorption reactor (Figure 3). The water manifold is also shown and a close view of the channels through part of the manifold in Figure 4. The whole assembly, in Figure 5, shows the flanges needed to retain the walls against internal ammonia pressures of up to 30 bar. The ammonia inlet/outlet connection is in the centre of the upper face. The threaded tie rods enable the reactor to be disassembled but a production version would be welded and hermetically sealed.

The carbon used (Chemviron SRD1352/3) is compacted into the 4 mm slots and initial estimates were that its effective conductivity would be $0.4 \text{ W m}^{-1} \text{ K}^{-1}$. The ammonia mass concentration (x) as a function of temperature (T) and saturation temperature (T_{sat}) is given by the Dubinin equation [5] as modified by Critoph [7]:

$$x = x_0 e^{-k \left(\frac{T}{T_{sat}} - 1 \right)^n} \quad (1)$$

Where:

$x_0 = 0.4288$ is the saturated mass concentration (kg adsorbate / kg adsorbent),

$k = 12.5626$ and $n = 1.7366$ are constants found by experimental curve fitting to porosity data measured using a Rubotherm magnetic suspension balance.

T is the temperature (K)

T_{sat} is the saturation temperature corresponding to the adsorbate pressure (K)

For testing in the laboratory, two sorption generators were constructed in a test rig as shown in Figure 6. Hot and cold water tanks of 120 litres capacity were used to provide water for heating or cooling the generators in a controlled fashion and solenoid valves enabled rapid switching of the hot and cold flows to each generator.

The ammonia leaving either generator was directed via a check valve to a water cooled plate condenser, rather than an air cooled condenser as in the vehicle application. This was more convenient in the laboratory when trying to maintain steady condensing conditions. The liquid ammonia was metered via two solenoid valves into a large flooded evaporator; again this was convenient for maintaining steady conditions in laboratory tests. The evaporator was used to chill a steady controlled water flow and the temperature drop monitored by K-type thermocouples.

As stated above, the total system volume should be less than 16 litres and mass less than 35 kg. Table 3 gives the mass and volumes of the whole system and components. The total volume is slightly over target, but achievable in a future version.

EXPERIMENTAL RESULTS

The sorption generator was initially evacuated and then filled with enough ammonia in order to raise the pressure to just above atmospheric, with the condenser and receiver disconnected. The generator was then put through several heating and cooling cycles corresponding to pressurization and depressurization of the generator with very little adsorption and desorption. The test conditions are:

- Heating water inlet temperature: 75°C

- Heating water flow rate: 12 litre min⁻¹
- Cooling water inlet temperature: 21°C
- Cooling water flow rate: 12 litre min⁻¹

The experimental results of the temperature profiles are presented in Figure 7. Water temperatures were measured by K-type sheathed thermocouples in the water flow at the inlet and outlet of the generator and the carbon temperature was measured by a 1 mm diameter sheathed K-type thermocouple inserted centrally in the central layer of carbon. Two complete cycles of heating and cooling are shown. Because the temperatures are measured in the inlet and outlet of the water flow and the flow direction reverses in heating and cooling, at each half cycle the hot inlet temperature becomes the cold outlet temperature and the cold inlet temperature becomes the hot outlet temperature. The heating and cooling is extremely rapid: cooling of the adsorbent from 75°C to 30°C with 21°C cooling water takes just 17 seconds.

The heat transfer performance can now be determined from these test results. Since no temperature was measured for the stainless steel shims of the sorption generator, only an overall heat transfer coefficient for the unit as a whole can be determined entirely experimentally. However, since the flow within the shims is laminar, the heat transfer coefficient in the fluid can be determined with some confidence. Additionally, the heat transfer coefficient in the fluid is an order of magnitude greater than that in the carbon adsorbent. Therefore, the heat transfer coefficient in the adsorbent can also be estimated from the experimental results. The heat flux per unit temperature difference (UA in $W K^{-1}$) value for fluid heat transfer has been calculated above at $4150 W K^{-1}$. From this and the overall UA value for the unit (as calculated from the measured heat input to the cooling water and lumping the thermal mass halfway to the centre of a carbon layer), the thermal conductivity of the carbon adsorbent can be calculated. This is carried out for the first cooling phase of the two cycles as shown in Figure 8 (The second cycle gives substantially the same results).

During the first 5 second period, the heat exchanger shims are heating rapidly which distorts the overall UA value of the unit and creates the apparent high adsorbent thermal conductivity. When a more stable state is reached and the majority of the heat transfer is to the carbon, a true value for the adsorbent conductivity can be obtained. The average value of $0.42 \text{ W m}^{-1}\text{K}^{-1}$ was calculated over a ten seconds measurement period. After this period, the fluid inlet and outlet temperatures become too close to determine an accurate value for the heat output due to measurement noise. The experimental value is extremely close to the $0.4 \text{ W m}^{-1}\text{K}^{-1}$ which has been assumed in previous computational modelling and was based on experimental measurements.

The prototype was subsequently tested for its cooling production while mounted on the full laboratory air conditioning system test rig driven by heat from water at up to 90°C . At the modest driving temperature of 90°C the benefit of thermal regeneration between the two generators is minimal and only mass recovery was used. One generator temperature and pressure cycle with 90°C driving temperature is shown in Figure 9. The bed is initially at its maximum temperature of 88°C . The combination of mass recovery (briefly opening a valve to the low pressure bed) and the sudden influx of cooling water results in a rapid drop in both temperature and pressure to about 55°C and 7 bar within about 5 seconds. The lower pressure and temperature result in a greater rate of adsorption of gas from the evaporator and an increase in the cooling power as can be seen in Figure 10. For the remainder of the half-cycle time of 75 seconds the cooling rate reduces as the bed temperature approaches the cooling water temperature and the cooling power (proportional to the rate of adsorption) declines from a peak of 2.3kW to 1.0 kW. There is a corresponding slight increase in the evaporating pressure during this period. At 75 seconds the mass recovery operation is carried out, hot water is switched to the bed and the pressure and temperature rise rapidly for the first 10 seconds. The rate of change of temperature decreases as the temperature difference between

bed and heating water decreases; the rate of desorption and hence condenser heat rejected falls, corresponding to the slight drop in the condensing pressure. The cooling power (Figure 10) from 75 to 150 seconds corresponds to the vapour from the evaporator going to the other bed. The cooling power in both half cycles is not completely identical, but this is due to minor and unintentional differences in the generators, occurring during the manufacturing process. The test conditions and results are presented in Table 4 both for nominal driving temperatures of 80 and 90°C. The average cooling production of 1.6 kW with mass recovery corresponds to an SCP of 114 W per litre of generator volume or 800 W kg⁻¹ carbon and a COP of 0.22 which is close to the target value of 0.24. The COP was calculated as the total cooling power integrated over a complete cycle divided by the high temperature input power to the generator integrated over the cycle. It should be remembered that the selection of the adsorbent (Chemviron carbon SRD1352/3) and the design of the generator was based on the maximum cooling production as the primary figure of merit rather than COP. Model predictions show that adding thermal enhancement material such as expanded natural graphite to the adsorbent could not only reduce the generator manufacturing cost but also improve the COP by up to a factor of 4 [7].

Figure 11 shows the cooling power with a driving temperature of 80°C. It can be seen that the cooling power drops from 1.6 to 1.26 kW. The COP was 0.23 which is below the target of 0.52 and the SCP dropped to 650 W kg⁻¹ carbon. The increased COP compared to the 90°C driving temperature case is due to the fact that the cycle time had not been optimised. The cycle time chosen was based both on simulation and some preliminary experimentation which indicated that it gave reasonable results. There will in fact be different optima maximising power or COP for different conditions. Later work will investigate the variation in detail.

The effect of coolant flow rates through the generator from 0.46 to 1.25 m³ h⁻¹ is presented in Figure 12. It can be seen that the effect of the flow rate on performance over the range tested is minimal, cooling power ranging between 1.4 and 1.6 kW and with no measurable difference in COP. The system should therefore not be significantly affected by the variation in the coolant water flow rate from the engine during the driving cycle.

The effect of varying the cooling loop inlet temperature to the evaporator is shown in Figure 13. The dramatic effect of decreasing evaporating temperature is evident, cooling power drops from 1.6 to 1.0 kW and COP drops from 0.22 to 0.15 as the water outlet temperature drops from 15 to 7.5°C. The approach between the saturation temperature and the water leaving the evaporator is fairly stable at about 2.5°C.

CONCLUSIONS

A pair of plate heat exchanger sorption reactors have been built and tested successfully in a laboratory test rig. SCP's as high as 800 W per kg of adsorbent have been achieved. Some, but not all of the thermal performance criteria have been met or exceeded. The current preliminary performance will be improved when operating the system with both mass and heat recovery; and with an optimised control strategy.

ACKNOWLEDGEMENTS

This research is supported by the EU- 'TOPMACS' project TST4-CT-2005-012394

NOMENCLATURE

x	ammonia mass concentration (-)
T	temperature (K)
T_{sat}	saturation temperature (K)
x_0	maximum ammonia mass concentration in Eq. (1)
k	constant in Eq. (1)

- n constant in Eq. (1)
- p absolute pressure (bar)

REFERENCES

- [1] Mola, S., Centro Recherche Fiat, private communication.
- [2] Critoph, R. E. and Metcalf, S. J. - Specific cooling power intensification limits in carbon-ammonia adsorption refrigeration systems - *Applied Thermal Engineering*, Vol. 24, Issues 5- 6, pp. 661-679, 2004.
- [3] Metcalf, S. J. – Gas-fired adsorption heat pump for domestic gas boiler replacement - *International Heat Powered Cycles Conference (HPC 2006)*, Paper No 06137, Newcastle, UK, September 2006.
- [4] Holman, J.P. Heat transfer, in: SI Units, seventh ed., McGraw-Hill, 1992, p. 289.
- [5] Critoph, R.E., ‘Adsorption Refrigerators and Heat Pumps’ from ‘Carbon Materials for Advanced Technologies’, ed. T.D. Burchell, Elsevier, 1999
- [6] Dubinin M.M., Astakhov V.A. *Adv. Chem. Ser.* **102**, 69, 1970.
- [7] Critoph, R.E., Lynch, P., Metcalf S.J. and Tamainot-Telto, Z.- Expanded natural graphite - Active carbon composite for adsorption heat pumps - *International Symposium on Innovative Materials for Processes in Energy Systems*, Tokyo (Japan), Paper A044, October 2007.

List of Table Captions

Table 1. System performance specification

Table 2: Generator characteristics

Table 3: Component volumes and masses

Table 4: Sorption air conditioning system results

Table 1. System performance specification

	Without auxiliary heater	With auxiliary heater
Generator desorption inlet	80°C	90°C
Generator adsorption inlet	33°C	33°C
Condenser inlet	33°C	33°C
Evaporator inlet	20°C	20°C
Heat source flow rate (Maximum)	1.44 m ³ /h	1.44 m ³ /h
Heat sink flow rate (Maximum)	1.44 m ³ /h	1.44 m ³ /h
Flow rate – Condenser (liquid)	0.30 m ³ /h	0.30 m ³ /h
Flow rate–Evaporator (liquid)	0.30 m ³ /h	0.30 m ³ /h
<i>Target performance</i>		
Cooling power	1.2 kW	1.2 kW
COP	0.52	0.24

Table 2: Generator characteristics

Type of carbon	SRD1352/3 (compacted)
Thermal enhancement additives	None
Carbon density	435 kg/m ³
Mass of carbon	0.915 kg
Maximum ammonia concentration	0.43 kg ammonia/kg carbon
Total weight of generator (without flanges)	9.5 kg
Volume of generator (without flanges)	3.5 litres
Type of gasket	PTFE Foam Sealant (RS-512-244)
Filter	Stainless Steel Mesh (Mesh grade 180)

Table 3: Component volumes and masses

	Volume (litres)	Mass (kg)
Adsorbent	12	2
Reactor heat exchanger	2	19
Refrigerant	Not applicable	1
Sorption reactor total	14	22
Condenser	2	4
Evaporator	1.2	2
Auxiliary equipment	2.7	2
Total	19.9	30

Table 4: Sorption air conditioning system results

	Nominal driving temperature 80°C	Nominal driving temperature 90°C
Cycle time (s)	150	150
Generator desorption inlet (°C)	82	92
Generator adsorption inlet (°C)	32	32
Condenser water inlet temperature (°C)	32	32
Evaporator water inlet temperature (°C)	20	21
Chilled water flow rate (l min ⁻¹)	5	5
Condenser water flow rate	5	5
Generator water flow rate	22	22
Average cooling power (kW)	1.3	1.6
COP	0.23	0.22

List of Figure Captions

Figure 1: Simplified schematic diagram of system within a car

Figure 2: Chemically etched shim

Figure 3: Reactor with one water manifold

Figure 4: Close view of water channels through part of water manifold assembly

Figure 5: Complete sorption generator

Figure 6: Laboratory test rig

Figure 7: Temperature profile during heating/cooling cycles

Figure 8: Adsorbent thermal conductivity identified from the experimental results

Figure 9: Temperature and pressure in a cycle with 90°C driving temperature

Figure 10: Cooling power in a cycle with 90°C driving temperature

Figure 11: Cooling power in a cycle with 80°C driving temperature

Figure 12: Effect of coolant flow rate on the system performance with 90°C driving temperature

Figure 13: Effect of evaporator water inlet temperature

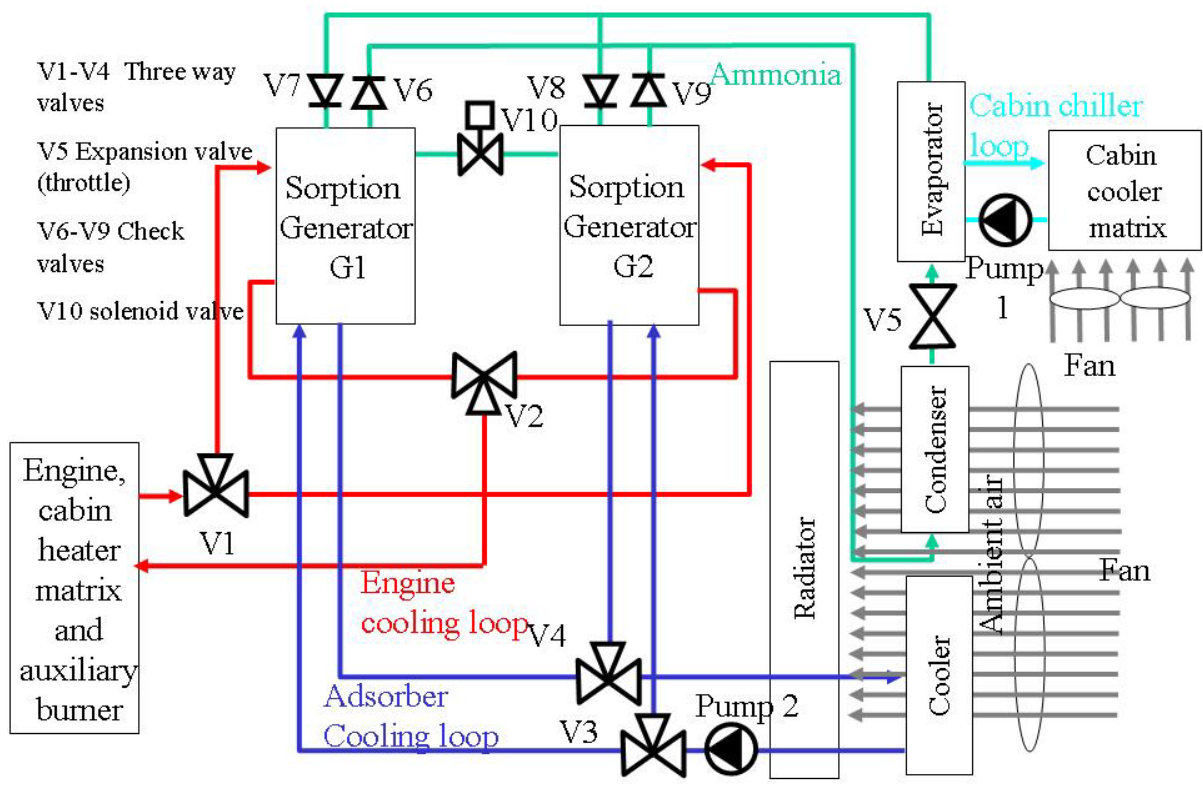

Figure 1: Simplified schematic diagram of system within a car

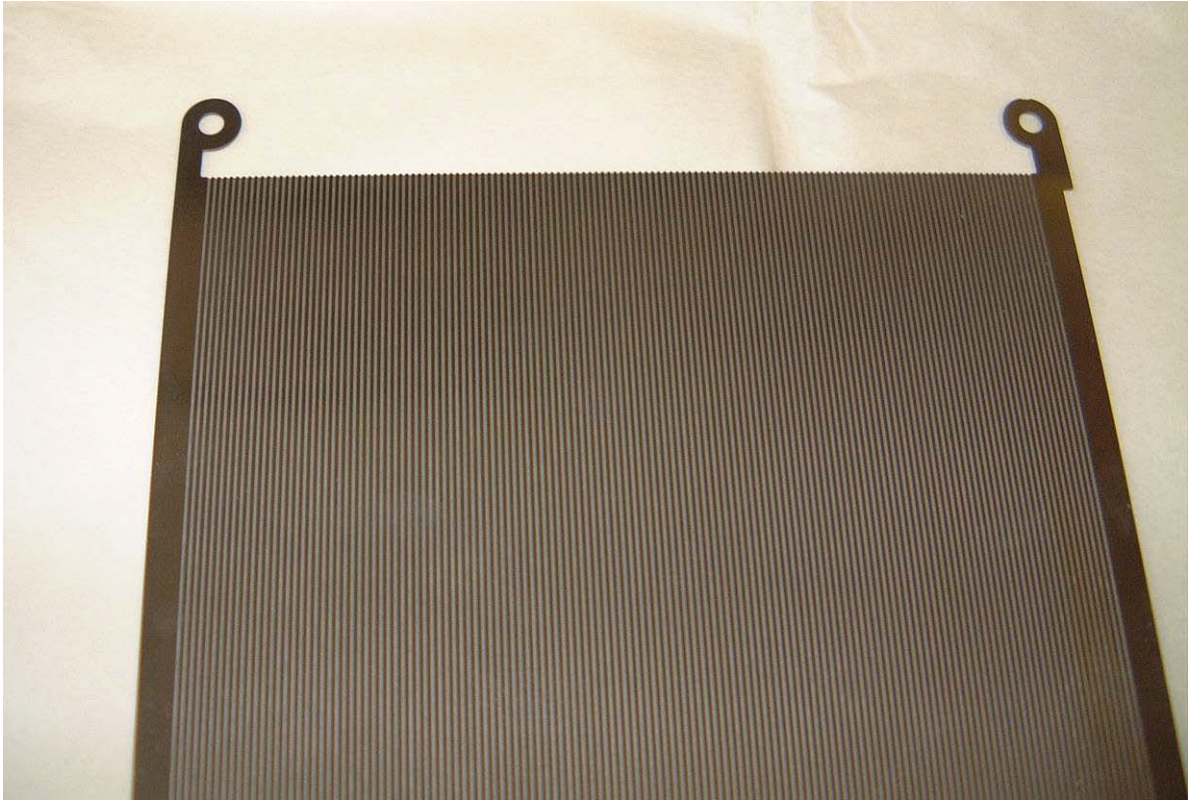

Figure 2: Chemically etched shim

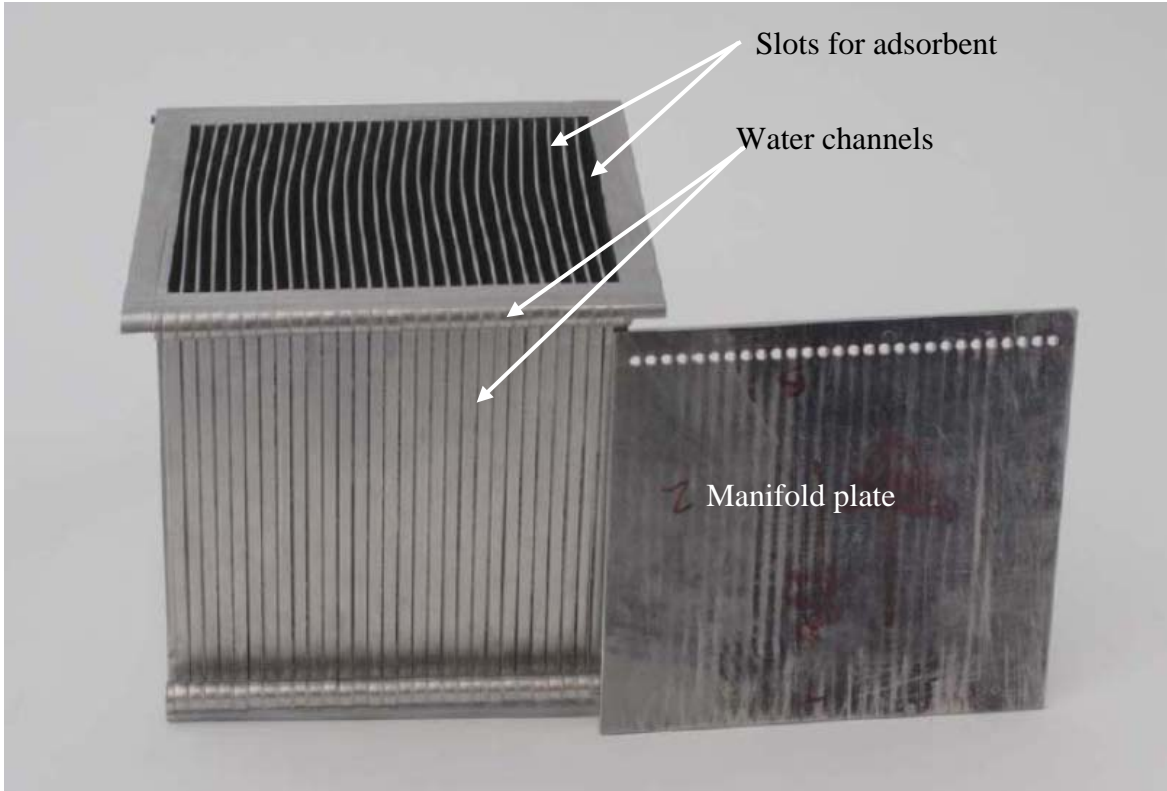

Figure 3: Reactor with one water manifold

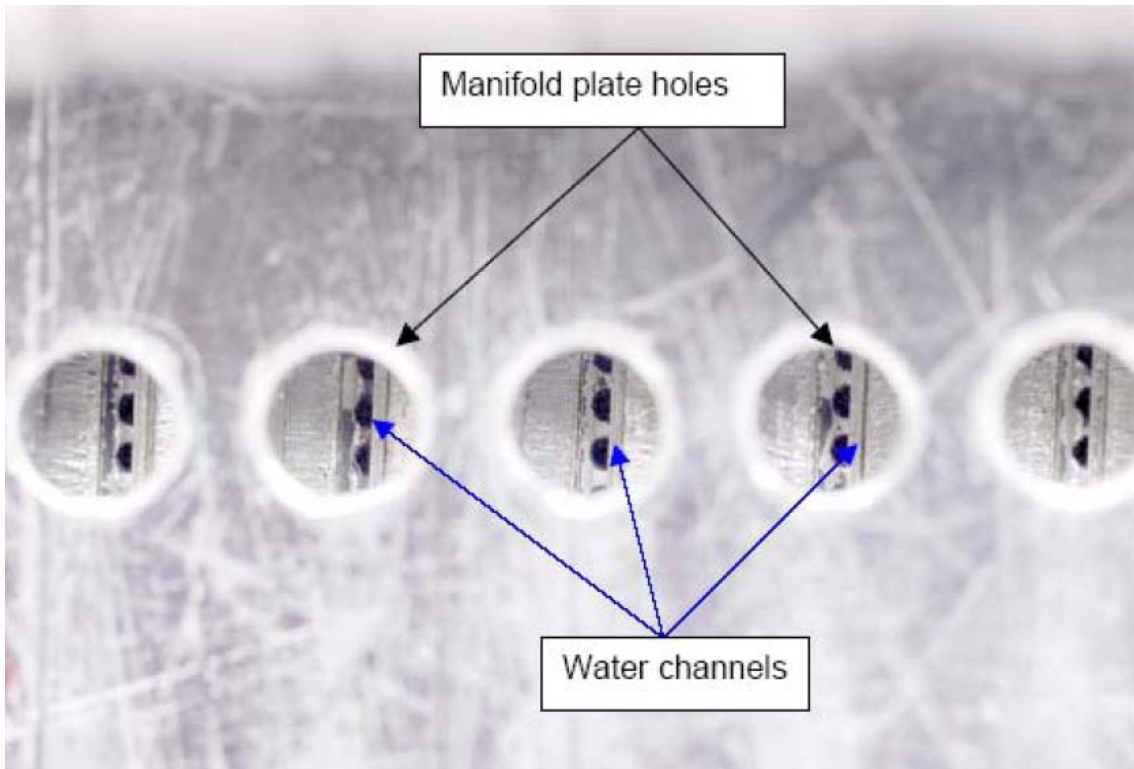

Figure 4: Close view of water channels through part of water manifold assembly

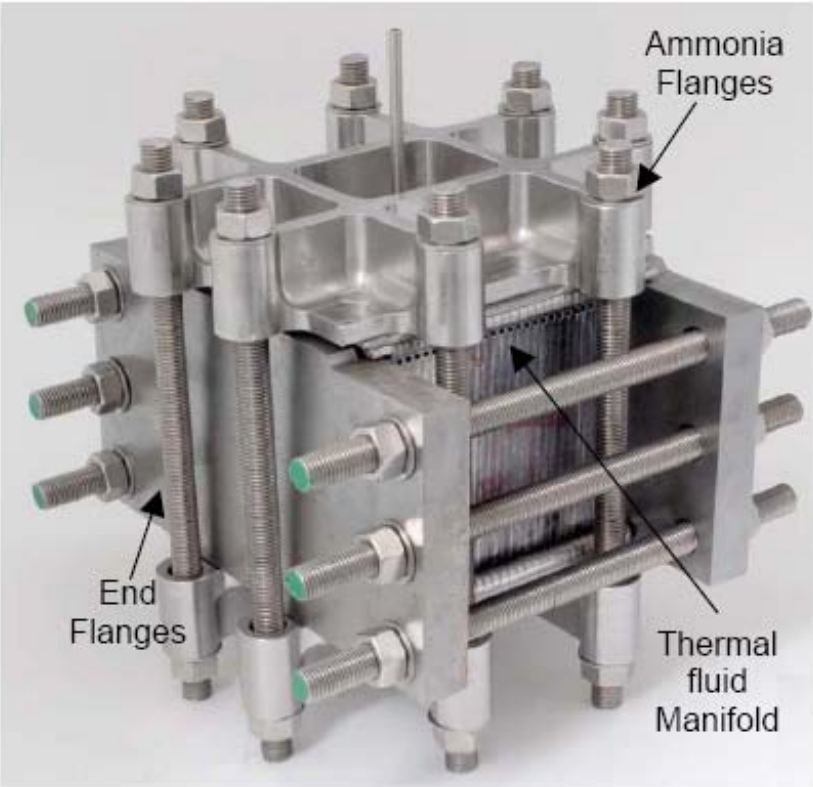

Figure 5: Complete sorption generator

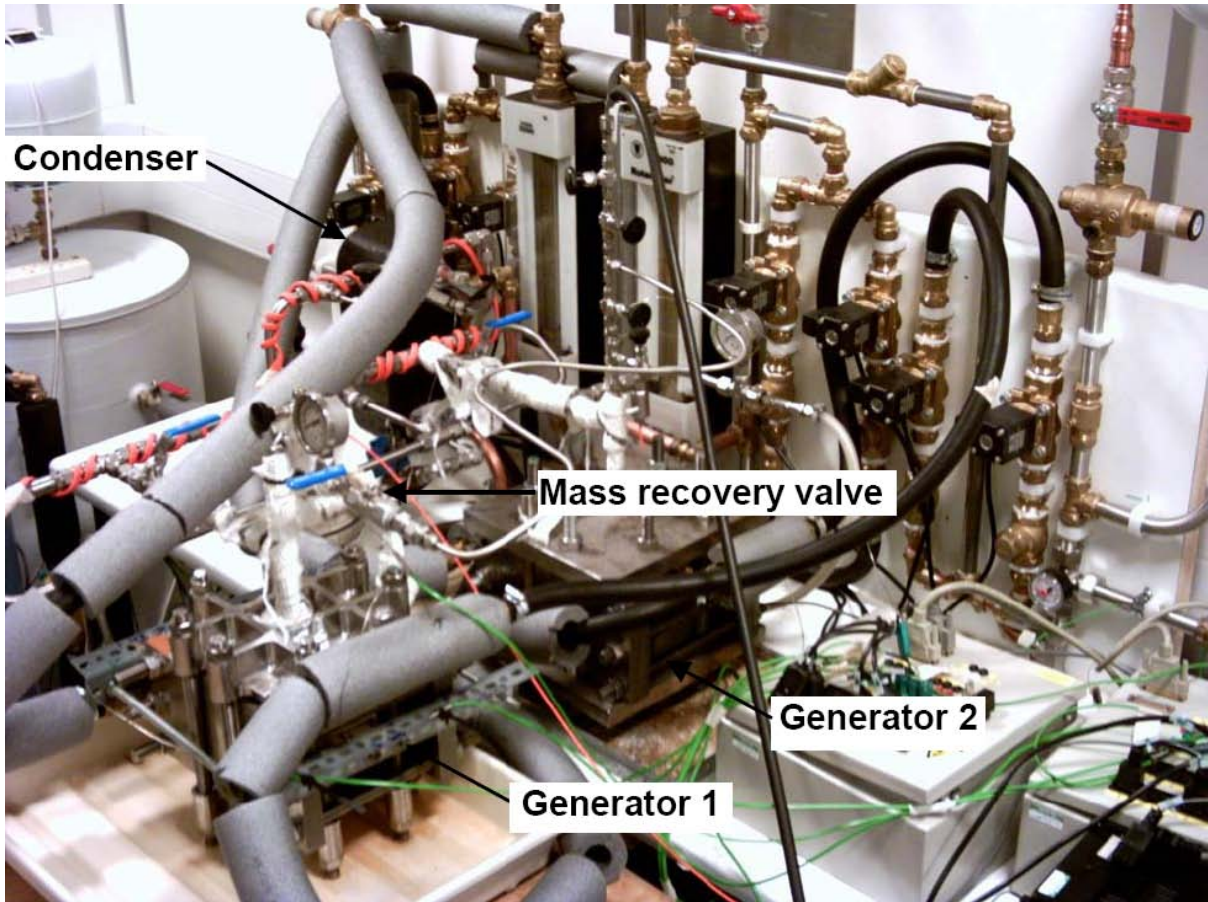

Figure 6: Laboratory test rig

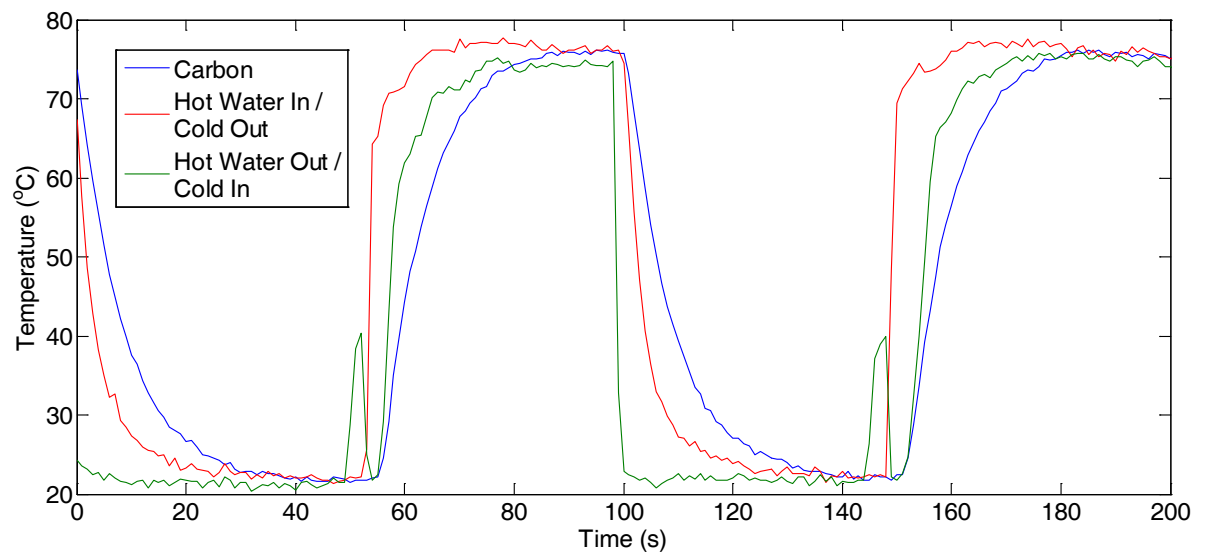

Figure 7: Temperature profile during heating/cooling cycles

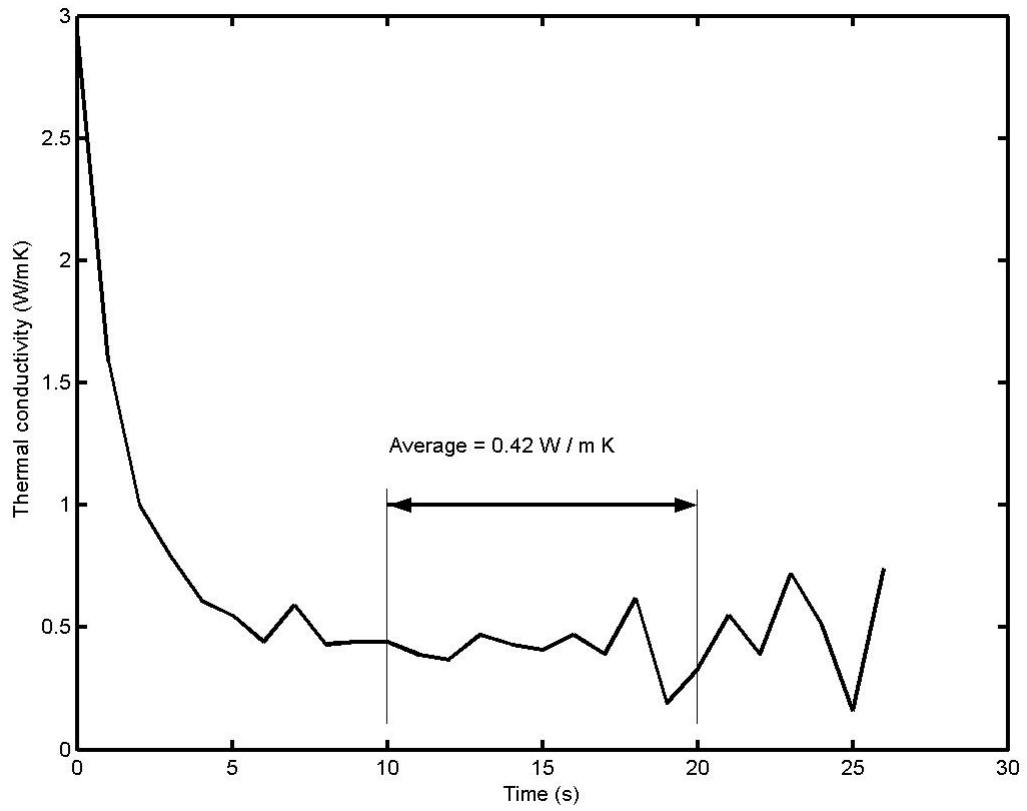

Figure 8: Adsorbent thermal conductivity identified from the experimental results

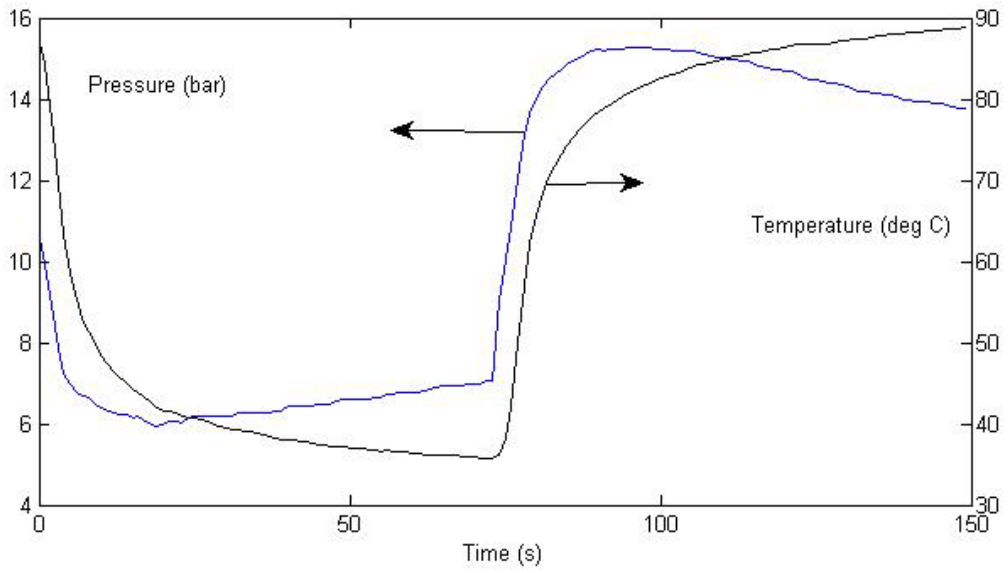

Figure 9: Temperature and pressure in a cycle with 90°C driving temperature

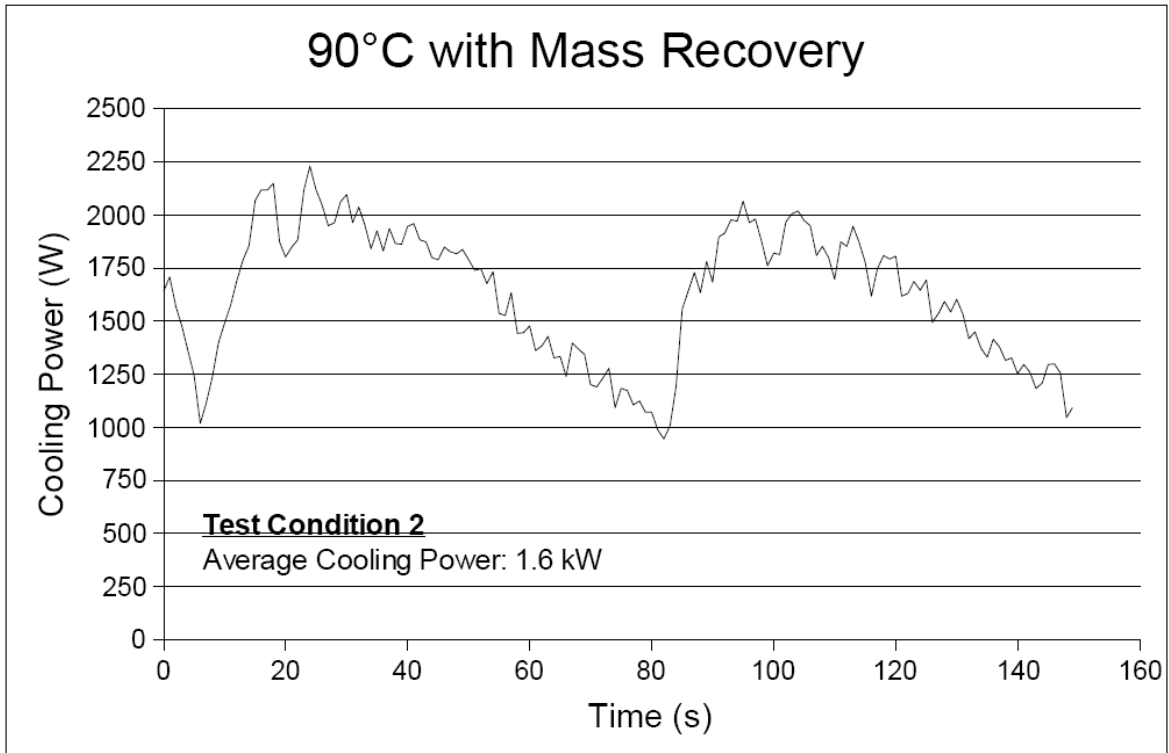

Figure 10: Cooling power in a cycle with 90°C driving temperature

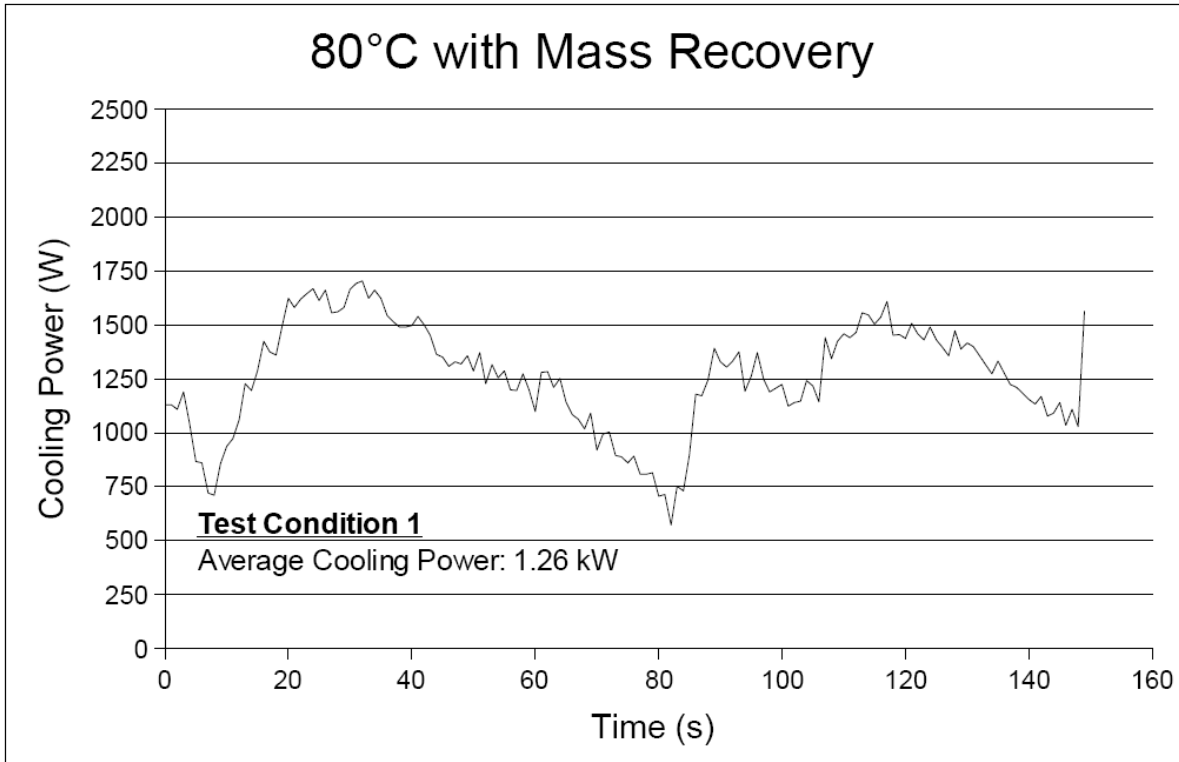

Figure 11: Cooling power in a cycle with 80°C driving temperature

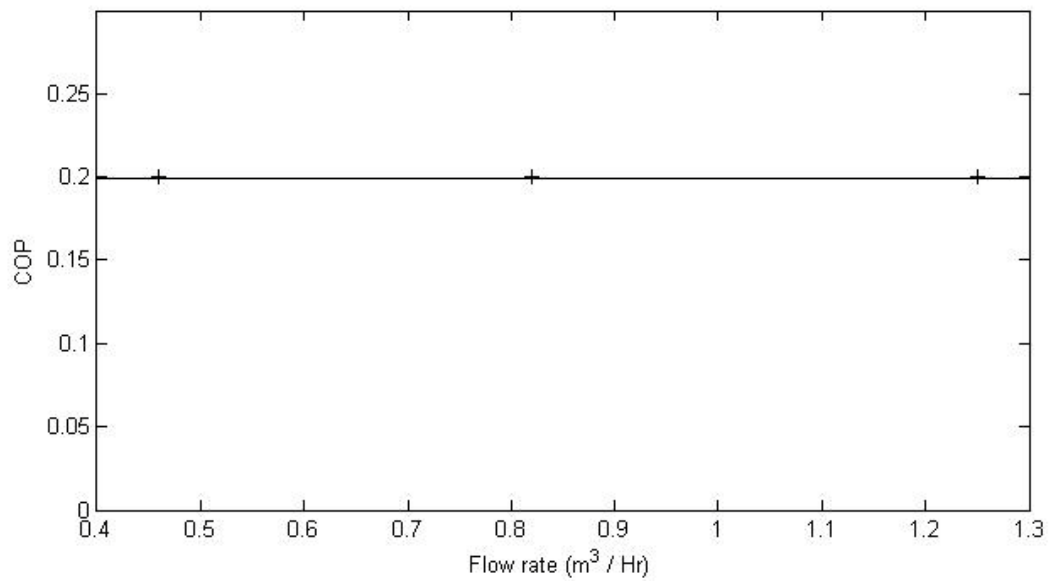
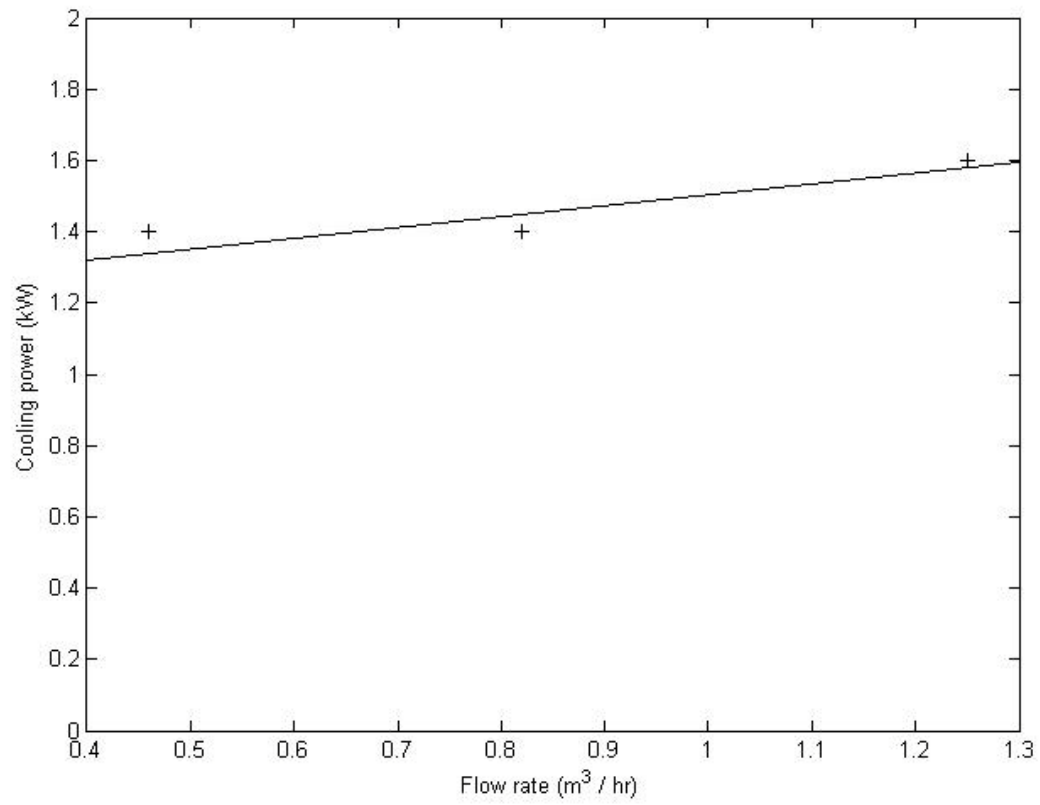

Fig. 12: Effect of coolant flow rate on the system performance with 90°C driving temperature

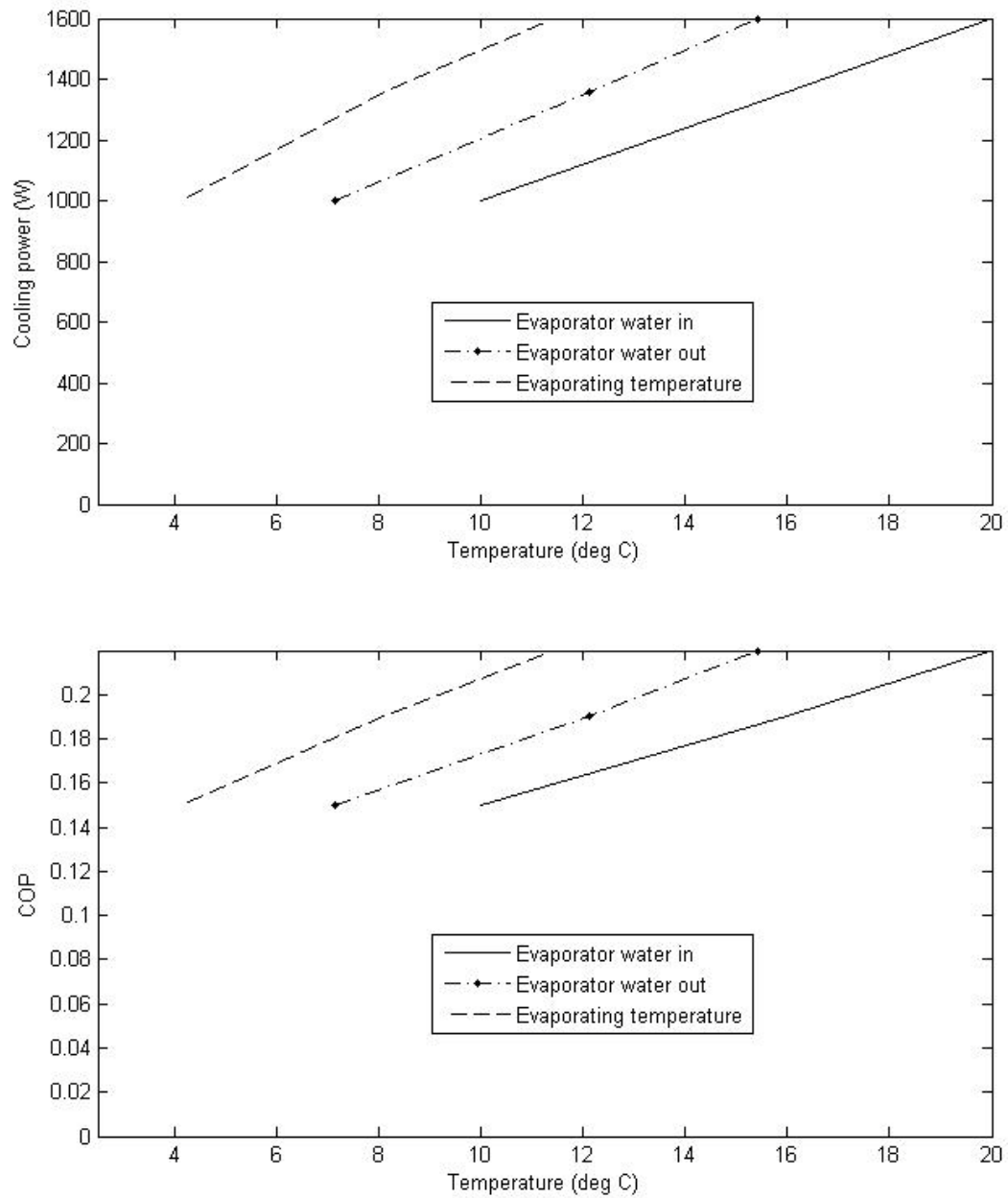

Figure 13: Effect of chilled water inlet temperature



Robert Critoph is a professor and head of the Sustainable Energy and Engineering Design research group of the School of Engineering in the University of Warwick. He obtained his B.Sc. in Aeronautical Engineering from the University of Southampton in 1972, and was awarded the 1972 Royal Aeronautical Society Prize. His PhD was from the University of Southampton in 1977 and his D.Sc. from the University of Warwick in 2007. He has worked in solid adsorption heat pump and refrigeration systems since 1986.



Steven Metcalf is currently a PhD student and research associate at the University of Warwick's School of Engineering. He gained a first class MEng degree in mechanical engineering at the university in 2004 and received the IMechE best student award. The design of a plate heat exchanger, to which he has made a significant contribution and which was carried out as part of an EU project, has recently been filed with the UK patent office.



Zacharie Tamainot-Telto graduated from the University of Nancy I in France (MST, 1988), National Polytechnic Institute of Lorraine INPL (MSc, 1990) and National Institute of Applied Sciences INSA Lyon (PhD, 1993). He joined the School of Engineering at the University of Warwick (UK) in 1994 and has held successively Research Fellow and Senior Research Fellow positions. He has worked on Sorption systems applied to heat pump and air conditioning for several years. He is currently Assistant Professor in Refrigeration, Heat Pumping and Energy Conservation since 2007. He is a UK Chartered Engineer and member of both Institution of Mechanical Engineers and Institute of Refrigeration.