

Original citation:

White, C. L., Attridge, A. N., Williams, M. A. (Mark A.), Skrypchuk, Lee and Hasedžić, Elvir (2013) Recreating daylight for readability assessments of in-vehicle displays. In: SID 20th Annual Symposium on Vehicle Displays , University of Michigan-Dearborn, Dearborn MI, 10-11 Oct 2013. <http://dx.doi.org/10.13140/2.1.4343.6160>

Permanent WRAP url:

<http://wrap.warwick.ac.uk/73777>

Copyright and reuse:

The Warwick Research Archive Portal (WRAP) makes this work of researchers of the University of Warwick available open access under the following conditions. Copyright © and all moral rights to the version of the paper presented here belong to the individual author(s) and/or other copyright owners. To the extent reasonable and practicable the material made available in WRAP has been checked for eligibility before being made available.

Copies of full items can be used for personal research or study, educational, or not-for-profit purposes without prior permission or charge. Provided that the authors, title and full bibliographic details are credited, a hyperlink and/or URL is given for the original metadata page and the content is not changed in any way.

A note on versions:

The version presented here is a working paper or pre-print that may be later published elsewhere. If a published version is known of, the above WRAP url will contain details on finding it.

For more information, please contact the WRAP Team at: publicatons@warwick.ac.uk

Recreating Daylight for Readability Assessments of In-Vehicle Displays

C.L. White, A.N. Attridge, M.A. Williams

WMG, University of Warwick
Coventry, West Midlands, UK, CV4 7AL. c.l.white@warwick.ac.uk

L. Skrypchuk, E. Hasedžić

Jaguar Land Rover Limited
Abbey Road, Whitley, Coventry, West Midlands, UK, CV3 4LF.

Abstract: *This paper describes the early stages of research into defining daylight scenarios encountered by vehicles and outlining which are the worst-case situations with respect to display readability. The main objective of the research is to design a facility capable of recreating a wide range of daylight scenarios to perform controlled, repeatable and reproducible readability assessments within automotive vehicles. This will be achieved through sky luminance mapping, display readability assessments under real skies and investigations into daylighting technologies.*

This is an engineering doctoral research project with WMG, University of Warwick and sponsored by Jaguar Land Rover.

Keywords: Automotive displays; artificial sky; daylight; readability

1 Introduction

Over the years there have been great advances in in-vehicle technologies. The use of display screens in the centre console and instrument cluster have become more commonplace. More and more vehicle systems are being controlled through a centralised display, making readability under ambient lighting conditions an important consideration for designers. To address the effects of screen washout and glare under changing ambient lighting conditions, in-vehicle displays have traditionally been recessed. However with the advent of touch screens this is no longer an appropriate solution due to the need for users to interface with the display directly.

During the design stage, optical ray tracing software is used to model the effects of daylight conditions and how light interacts with the internal environment of the vehicle. This enables designers to see how different displays with a variety of optical properties perform under a wide range of ambient lighting conditions, depending on the position and orientation of the display. The optimal design of display location within the centre console will be where the effect of daylight on readability is the least detrimental.

The final design will still need to undergo readability assessments to verify the performance of the display for a specified number of lighting conditions. Assessments under real skies would not provide adequate control and repeatability due to the changeable nature of the sky. Therefore, the solution is to test under controlled artificial lighting that gives a good representation of daylight. A range of solutions exist to perform these assessments based on ISO international standards, with some facilities being more sophisticated than others. However, these standards do not define the contribution of the sky component of daylight and whether or not the illumination test set-up stipulated gives a good representation of daylight, comparable to real-world scenarios.

The challenge for the automotive industry is to standardise the daylight illumination environment for performing assessments and to make measurements controlled, repeatable and comparable to real daylight situations [1].

2 Readability issues for automotive displays

2.1 Display reflections

Ambient light within the vehicle cockpit is reflected from different surfaces in all directions. Reflected light at the display becomes a problem when it travels back to the driver's eye point, and is perceived as any combination of the three components of reflection [2];

Specular: directional reflections that produce mirror-like images at the display.

Lambertian: diffuse reflections independent of direction. A uniform wash of light is superimposed on the image of the display resulting in a loss of contrast.

Haze: diffuse reflections in the direction of the source of illumination that produces a fog-like effect over the display image.

Both the specular reflections (also known as glare) and diffuse reflections (commonly referred to as washout) degrade the performance of the display resulting in low image quality and reduced readability [1].

2.2 Automotive design & testing

During design of the vehicle, the display geometry with respect to driver's eyepoint is established, and an assessment on this geometry is performed to give the optimal orientation of the display. Traditionally these assessments were performed using a prototype vehicle and a manikin to define the viewing angles. In many cases the manual assessments are still performed, however it is now possible to perform simulations using optical ray tracing software or photometric light simulation software (such as SPEOS [3]). Simulations are performed to avoid a direct specular situation that will impair the driver [4] as well as to consider the use of additional technologies to improve the readability of the display.

Photometric light simulations of the display under assessment, give a good indication of how the display will perform under ambient daylight conditions, but as with all computer generated designs, quality assurance requires verification measurements to prove that the requirements of the design have been fulfilled [5].

2.3 Display daylight readability

International standards have been developed to assess the daylight readability performance of a display. ISO 15008 [6] and SAE J1757-1 [7] define the minimum requirements for readability and outline 'High Ambient Illumination Contrast Ratio Measurements' of displays specifically for automotive applications, recommending two measurement methods.

In-situ measurement: The method simulates two situations; diffuse sky and direct sun which are simulated separately (see Figure 1). This method has the advantage of being able to be performed within the vehicle under assessment; however it is also possible to set up the tests with vehicle geometry on the test bench.

Integrating (Ulbricht) Sphere: this setup simulates the diffuse ambient condition; daylight without direct sun exposure. This method cannot be performed within the vehicle and has a set geometry (see Figure 2).

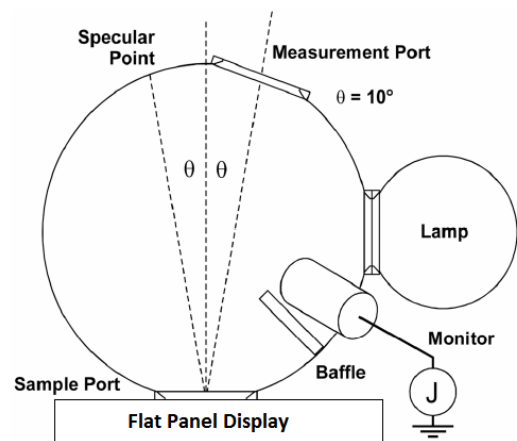

Figure 2: Measurement set-up using an Integrating Sphere [7]

Measurements under these conditions can be used to compare the different ambient light performance between displays. However, these set-ups are not realistic representations of daylight due to measurements under direct sun and diffuse sky being taken separately and only for a single source geometry [1]. Under real skies, light will be reflected off all surfaces from all directions within the vehicle, and cannot exist without the solar component.

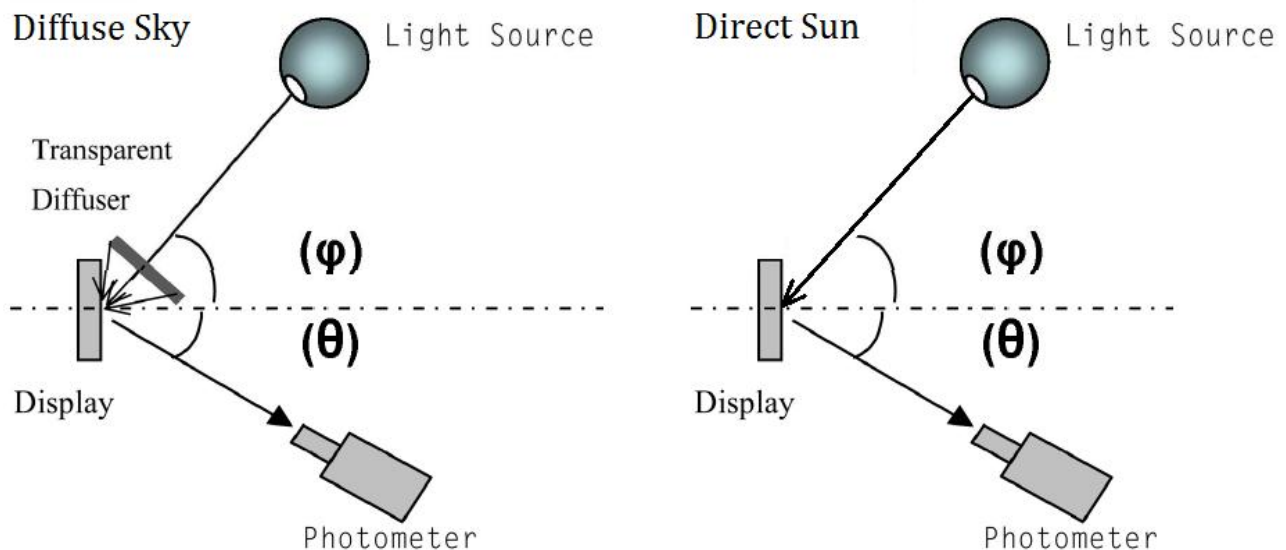

Figure 1: SAE J1757-1 Real Life/In Car Measurements Using High Ambient Light Illumination Simulation Geometry (Plan view); Diffuse Sky (left) and Direct Sun (right) [based on 7]

3 Recreating daylight

To recreate illumination scenarios in a laboratory environment the basic components of daylight need to be considered; the direct sun, the direct sky and the external and internal reflections. These factors, and how they interact with each other, contribute to the ambient light within a space. One of the more complex elements to artificially recreate is the sky component due to its constant variation in intensity, direction and distribution.

The objectives of this project are to:

- Recreate daylight illumination for in-vehicle display readability assessments and design and cost for an illumination test facility.
- Define different illumination scenarios that a specific vehicle will encounter and specify the worst-case situations with respect to readability.
- Define the impact of the sky component of daylight on display readability.
- Propose best-practice of illumination readability test procedure.

3.1 Artificial Skies

Artificial skies are used by architects, engineers, researchers and students, to assess scale models for daylighting design and analysis of buildings.

When used in conjunction with sun simulators, artificial skies can simulate the daylight luminance distribution for most times of day and year at different locations.

There are two types of artificial sky; full covering and partial covering skies.

A full covering sky recreates the entire sky vault around the scale model. This allows illuminance measurements to be taken and the interactions between light and surfaces throughout the model to be observed. The following are examples of full covering skies:

Mirror box sky is a light box with mirrored walls and translucent ceiling through which light from luminaires are diffused [8]. A uniform luminance distribution is produced through the inter-reflections of the light from the mirrored walls and a good approximation of the CIE standard overcast sky is simulated [9].

Sky domes are opaque, reflective domes [10] diffusely lit from below, by an array of perimeter lamps, or a translucent inner dome with lamps mounted within an outer dome [11]. The luminance distribution can be fine-tuned by adjusting the luminaires, to display uniform or CIE standard overcast skies.

Point source simulators (Figure 3) are full hemispherical domes comprising a number of individually addressable luminaires which represent the sky vault [12]. This flexibility of the luminaires allows for any sky condition to be generated including predefined CIE standard skies and measured sky luminance distributions.



Figure 3: Point Source Artificial Sky Dome. Photo taken at University College Dublin, November 2011

Partial covering skies simulate a small section of the sky and utilise mathematical modelling of the measurements taken during the simulation to produce the full luminance distribution of the sky vault. The following are examples of partial skies:

Scanning Sky Simulator is a 1/6th partial sky [13] [14] which rotates about the model under assessment to make up the full sky vault. The luminance distribution of the full sky is compiled from photometric measurements and digital images of each scan allowing the reproduction of CIE and measured sky distributions.

Single Patch Sky models a single area of the sky vault and a fixed sun simulator. The scale model being assessed rotates and measurements of luminance, illuminance are recorded. A weighting factor for each patch is applied to give the required distribution of CIE and measured skies [15].

Existing artificial skies are used on a small scale, and are not capable of performing assessments on a full size vehicle. However, with proper consideration and application, this technology will provide the basis for analogous daylight conditions for in-vehicle illumination assessments.

4 Sky capture & readability assessment

The luminous environment that a vehicle will most likely encounter will be defined through the measurement and mapping of the luminance distribution of the sky. This will be done while assessing the readability of the centre console display, which will show the influence of different skies on display readability. Additionally, data will be provided to recreate the luminous environment in a computer simulation.

The experimental set-up for both sky capture and assessment of readability needs to be designed carefully to ensure controlled, repeatable and useful measurements.

4.1 Sky capture

In this research, the sky capture will be performed with the use of a pro-metric PM-1600 CCD camera with an 8mm fisheye lens. This type of camera allows the sky luminance data to be captured per pixel giving greater accuracy of the sky luminance distribution. This technique will also provide an image of the sky to allow classification of sky type (Figure 4).

Initial setup investigation will be required to ensure that the CCD sensor does not become saturated. A combination of ND filters and possible shades for the circumsolar region will be considered.

Calibration of the camera and the lens is required to reduce distortions associated with the lens, cosine fall-off, vignetting and non-uniformity of the CCD sensor [16].

The camera set-up will be defined with respect to the vehicle position to provide comparability between experimental setups at different locations. It would also be useful to evaluate the local environment with respect to possible sources of external reflections.

4.2 Readability

Under varying skies, the reflected illuminance at the display and colour contrast will be measured and characterised with the use of a photometric camera. These measurements will be further assessed using the perceived just noticeable difference (PJND) method [17] to determine readability.

The set up shown in Figure 5 will be the basis for the readability experiment. To make the procedure more repeatable a mechanical fixture to mount the camera is required.

This fixture will need to provide adjustment to position the camera relative to the driver's eyepoint and to the correct working distance of the camera relative to the display. There is also a requirement to provide a simple method to align the camera to the centre of the display.

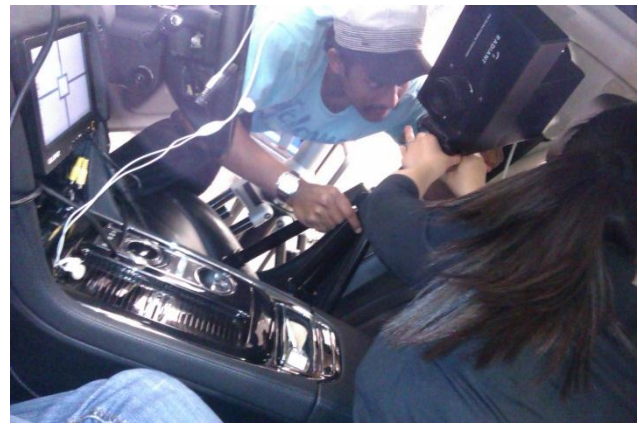

Figure 5: Typical set-up for in-vehicle display assessments based on ISO 15008 [6] and SAE J1757-1 [7]

As well as controlling the optical geometry of the setup, the environment that the measurements are recorded in must also be defined.

The vehicle interior should be defined to ensure comparability of measurements if the vehicle used for testing is different for different locations.

The following parameters should be controlled for each test:

Vehicle make and model, interior colours and finishes: This should remain the same for each test to control the internal reflections within the vehicle. Ensure that the same make and model of display is fitted for each test.

Passenger: if there is a passenger within the vehicle it should be the same person, in the same location, wearing the same colours. Any variation should be noted as this could affect the reflections within the vehicle.

Age of display: over time the optical characteristics of a display can change [18].

Temperature: The internal temperature of the cockpit should be recorded as heating of the display can change its optical characteristics [18].

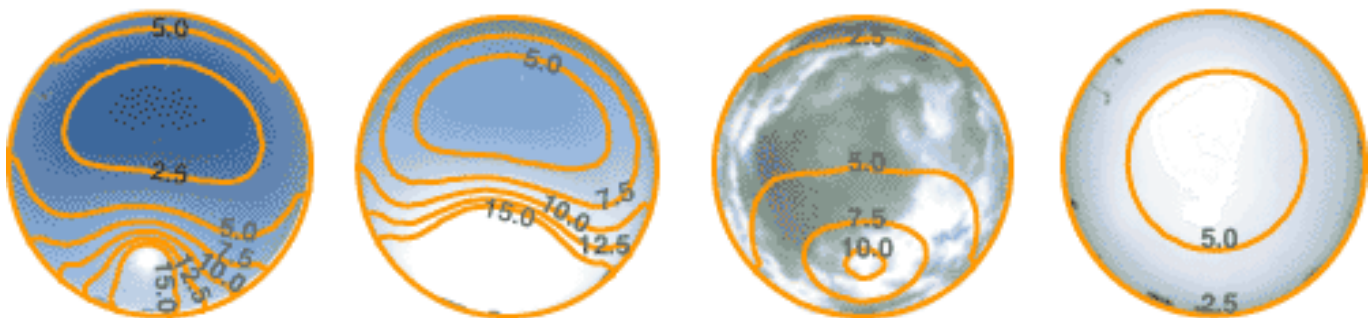

Figure 4: Classification of basic sky types [21] (from left to right) Cloudless, Cloudless Turbid, Intermediate & Overcast

4.3 *The influence of the 'sky' component*

By defining the influence of the sky on readability assessments the level of accuracy required by the daylight facility will be indicated.

A computer simulation of the measured sky and the reflections at the display will be produced. The sky component of daylight within the vehicle can then be isolated and compared to the influence of the full model.

The sky component through an aperture can also be calculated [19]. This can be used in conjunction with the computer simulation to verify the influence of the sky component of daylight at the display screen.

The influence of correlated colour temperature (CCT) variation of the sky throughout the day will also be considered. This will affect the selection of light source and luminaire design with the possible introduction of daylight filters.

4.4 *Illumination scenarios*

The illumination scenarios of most interest for vehicle assessment are those considered to be most detrimental to readability. The 'worst case' illumination scenarios will be defined using experimental data and will be based on the following parameters:

Global location: Identify the global locations where the display is most affected by poor readability.

Sun position: Identify detrimental sun positions with respect to the orientation of the vehicle and position of the driver. This is dependent on global location, time of day and time of year.

Sky condition: Identify the different types of sky (see Figure 4) and how they affect readability. Factors such as cloud cover and pollution (turbidity) are also important in defining the sky condition.

Daylight availability: The duration of a situation (per year) where the sky condition and sun position are detrimental to readability is also an important criterion for determining a 'worst case scenario'.

5 **Factors affecting simulator requirements**

5.1 *Internal reflections*

Daylight enters the vehicle cockpit from all around; through the windows, sunroof, convertible roof, and more recently through panoramic glass roofs. To perform illumination evaluations within a vehicle, a fully immersive environment is required to allow for daylight from all directions.

5.2 *Components of daylight*

The 'direct sun' component of daylight will need to be recreated with a sun simulator. This will model the position of the sun at different times of day and year at different latitudes, and also show the changes in direct solar illuminance.

How the 'sky component' is to be recreated will depend on how significant its effect is on the readability of displays.

It is possible that the effect of sky is negligible. In which case, a uniform distribution of luminance in conjunction with a sun simulator will be sufficient to perform evaluations. However, if the changing distribution of the sky is seen to have a significant effect, it will be necessary to simulate real sky luminance values and distributions.

5.3 *Quantitative and qualitative evaluations*

During vehicle interior evaluations, it is important to assess and record illuminance variations that are detectable to human vision. This can be achieved with photometric imaging equipment. Photometric measurements are important for control and to quantify the variation of illuminance at the area under evaluation. Images captured by the cameras can be assessed subjectively and immediately show engineers and designers any areas for concern. The images are also useful to qualify what the customer will 'see' in each simulated situation.

5.4 *Real-time assessments*

In addition to photometric and imaging equipment, real-time assessments may be required. This may mean that true illumination levels with respect to the sky and sun will need to be simulated without the need for scaling factors to be applied to the luminance distribution.

Real-time assessments have the benefit of being able to perform qualitative assessment and allow the person performing the evaluations to see and experience the vehicle under the same lighting conditions as a driver. It would also allow customer satisfaction assessments of the real vehicle environment from within the simulator.

6 **Simulator characteristics**

6.1 *Size*

The size of the facility needs to be large enough to house the vehicle under assessment, with clearance to move freely around the vehicle whilst carrying equipment. The clearance must take into account any minimum safe distance for personnel to operate within the simulator, due to intensity of the light sources.

The required space will need to be designed around other equipment; a sun simulator and its rigging/track, air-conditioning vents/conduit, and measurement equipment and simulator controls.

The size of the facility is also dependant on the simulator type to be recreated. For example, point light source simulators used to assess daylighting within scale models of buildings, limit the size of the model under assessment to 5:1 to reduce the influence of parallax errors [9]. In terms of this vehicle evaluation facility, the simulated sky would need to have a diameter five times the length of the largest vehicle to be assessed.

Such a large facility would be expensive and difficult to achieve. The necessity depends on how significant parallax errors are in this context. There is the possibility that parallax errors can be considered to be negligible for a small area of regard, such as a display screen, close to the centre point of the dome [20].

6.2 Access

An entryway to the simulator needs to be considered for both the vehicle under evaluation and for personnel performing assessments.

Assuming the simulator is a full covering sky, any access point will need to be integrated into the sky and be indistinguishable from the surrounding area. Alternatively, the access route for the vehicle may be via a lift platform from below and possibly a trapdoor to a stairwell for personnel.

6.3 Illumination sources

The type of lamp and number required will depend on the type of sky being created and the luminous output to be generated.

There are a number of illumination sources available and before selection for the simulator can be made, an investigation into the suitability of available light sources needs to be performed. LEDs and fibre-optics are among the types of source to be considered, as well as compact fluorescent lamps. Many existing simulators utilise compact fluorescents due to low power consumption, compact size and range of available colours.

The lamp characteristics to be investigated include;

- Correlated Colour Temperature (CCT)
- Radiometric & photometric output
- Variation between sources
- Lamp life

6.4 Errors & Uncertainty

A detailed investigation is required to identify system errors inherent to the simulator, possible measurement errors associated with the photometric imaging equipment and operator errors.

Both the magnitude of these errors as well as possible ways to control or mitigate them within the simulator needs to be addressed.

6.5 Equipment

Measurement equipment for use with the simulator will include the video photometer used to perform interior evaluations as well as photometers to monitor and measure the distribution of the 'sky'.

As well as the sky, a sun simulator is required to simulate the direct sun component of daylight. Sun simulators are generally a moveable light source with parallel beams, or a lamp plus a device to collimate the light, such as a parabolic mirror. Fabrication of a perfect parabolic mirror is challenging and expensive, therefore an investigation into other available technologies such as liquid lenses and mylar mirrors is worthwhile.

The mechanism for changing the position of the 'sun' could be a curved arm on a circular track in the floor. This would allow the sun to change position vertically (elevation) along the arm and horizontally around the simulator on the track (azimuth). Another possibility is a fixed track that follows the curvature of the sky to change the elevation of the sun, and the azimuth can be simulated with the use of a heliodon.

With the addition of a star simulator and other situational lighting, the artificial sky can be used to reproduce night-time situations. Assessments on vehicle interiors as seen under street lighting and interior illumination can be performed, as well as studies into distraction and glare from oncoming headlights.

The quality of external reflections can be altered with the addition of different ground surfaces. This can be used to simulate different road surfaces (such as tarmac, concrete, dirt-track, desert roads etc.) and changing conditions (such as rain, snow, ice, salt and grit etc.).

7 Conclusions

Due to issues associated with ambient lighting at the display screen, a facility is required to perform evaluations comparable to real daylight situations. This facility will be based on artificial sky technologies.

For a range of daylight scenarios to be defined and recreated, it is necessary to understand the influence of the different components of daylight and how they affect the readability of the display.

The 'sky capture & readability' experiment will aid this understanding and will also address what type of simulated sky is suitable for vehicle interior evaluations and display readability assessments.

The design of the facility will be based on the results of investigations into the types of illumination sources suitable for daylight recreation and also the errors associated with artificial skies and uncertainty of measurement.

The basic requirements of an artificial sky to perform vehicle interior evaluations are a full covering sky, a sun simulator and photometric imaging equipment to perform qualitative and quantitative assessments.

Other features can be added to the simulator to give greater versatility to vehicle interior evaluations and subjective research studies.

8 Acknowledgements

This work is supported by the Engineering and Physical Sciences Research Council [EP/I01585X/1].

9 References

- [1] K. Blankenbach, "Display Metrology," in *Handbook of Visual Display Technology*, Springer-Verlag, 2012.
- [2] E. F. Kelley, G. R. Jones, and T. A. Germer, "The Three Components of Reflection," *Information Displays*, vol. 10, pp. 24-29, 1998.
- [3] OPTIS, "Light Modeling," *SPEOS CAA V5 Based*, 2013. [Online]. Available: www.optis-world.com/products/software/speos-LM-CAAV5.html. [Accessed: 11-Sep-2013].
- [4] P. Weindorf and B. Hayden, "Automotive Display Visibility Considerations," *SID Symposium Digest of Technical Papers*, vol. 44, no. 1, pp. 555-558, 2013.
- [5] H. Czichos et al., "Fundamentals of Metrology and Testing," in *Springer Handbook of Metrology and Testing*, H. Czichos, T. Saito, and L. Smith, Eds. Berlin, Heidelberg: Springer Berlin Heidelberg, 2011.
- [6] British Standards Institution, "BS EN ISO 15008:2009. Road vehicles — Ergonomic aspects of transport information and control systems — Specifications and test procedures for in-vehicle visual presentation." BSI, London, 2009.
- [7] SAE International, "SAE J1757-1: Standard Metrology for Vehicular Displays." SAE International, 2007.
- [8] B. Matusiak and H. Arnesen, "The limits of the mirror box concept as an overcast sky simulator," *Lighting Research and Technology*, vol. 37, no. 4, pp. 313-328, Dec. 2005.
- [9] P. J. Littlefair and C. R. T. Lindsay, *BEPAC Technical Note 90/30, Scale models and artificial skies in daylighting studies*. Building Research Establishment, 1990.
- [10] S. Selkowitz, "A hemispherical sky simulator for daylighting model studies," in *Sixth National Passive Solar Conference*, 1981.
- [11] D. C. Croghan, "Transilluminated domical artificial sky," *Light and Lighting*, vol. 57, pp. 290-293, 1964.
- [12] The Bartlett, "Lighting Simulator," *University College London*, 2013. [Online]. Available: <http://www.bartlett.ucl.ac.uk/about-us/facilities>. [Accessed: 15-Jun-2013].
- [13] L. Michel, C. Roecker, and J.-L. Scartezzini, "Performance of a new scanning sky simulator," *Lighting Research and Technology*, vol. 27, no. 4, pp. 197-207, Dec. 1995.
- [14] C. Aghemo, A. Pellegrino, and V. R. M. Lo Verso, "The approach to daylighting by scale models and sun and sky simulators: A case study for different shading systems," *Building and Environment*, vol. 43, no. 5, pp. 917-927, May 2008.
- [15] M. Bodart, A. Deneyer, A. De Herde, and P. Wouters, "Design of a new single-patch sky and sun simulator," *Lighting Research and Technology*, vol. 38, no. 1, pp. 73-89, Jan. 2006.
- [16] P. Kenny, J. Olley, and J. O. Lewis, "Whole-Sky Luminance Distribution Maps from Calibrated Digital Photography," in *Proceedings of the EuroSun 2006 Conference (CD)*, 2006.
- [17] K. Vassie, "Specification and assessment of the visual aspects of cockpit displays," *SID Symposium Digest of Technical Papers*, vol. 29, no. 1, pp. 1199-1203, 1998.
- [18] E. F. Kelley, M. Lindfors, and J. Penczek, "Display daylight ambient contrast measurement methods and daylight readability," *Journal of the Society for Information Display*, vol. 14, no. 11, pp. 1019-1030, 2006.
- [19] M. Andersen, "Extension of the sky component calculation method to tilted windows," in *IESNA 2004 conference, session Daylight Modeling*, 2004, pp. 1-12.
- [20] C. White, "Telephone conversation with John Mardaljevic, 12/01/2012." Reader in Daylight Modelling, IESD, De Montfort University, Leicester, 2012.
- [21] Satel-Light, "Sky Types and Luminances," *Satel-Light Advanced User Guide*. [Online]. Available: <http://www.satel-light.com/guide/advlum.htm>. [Accessed: 16-May-2013].