

Original citation:

Gardner, J. W., Wei, G. , Vincent, Timothy A., Volans, K, Tremlett, P. , Wotherspoon, T. and Dyer, David. (2015) A gas sensor system for harsh environment applications. Procedia Engineering, 120. pp. 275-278.

<http://dx.doi.org/10.1016/j.proeng.2015.08.608>

Permanent WRAP url:

<http://wrap.warwick.ac.uk/76971>

Copyright and reuse:

The Warwick Research Archive Portal (WRAP) makes this work of researchers of the University of Warwick available open access under the following conditions.

This article is made available under the Creative Commons Attribution-NonCommercial-NoDerivatives 4.0 International (CC BY-NC-ND 4.0) and may be reused according to the conditions of the license. For more details see <http://creativecommons.org/licenses/by-nc-nd/4.0/>

A note on versions:

The version presented in WRAP is the published version, or, version of record, and may be cited as it appears here.

For more information, please contact the WRAP Team at: publications@warwick.ac.uk

warwick**publications**wrap

highlight your research

<http://wrap.warwick.ac.uk>



EUROSENSORS 2015

A Gas Sensor System for Harsh Environment Applications

J.W.Gardner^{a*}, G.Wei^b, T.Vincent^a, K.Volans^a, P.Tremlett^c, T.Wotherspoon^c, D.C.Dyer^a

^a*School of Engineering, University of Warwick, Coventry, CV47AL, United Kingdom*

^b*School of Information and Electronic Engineering, Shandong Institute of Business and Technology, Yantai, 264005, P.R.China*

^c*Microsemi Ltd, Monmouthshire, NP26 5YW, United Kingdom*

Abstract

A novel low power, miniature gas sensor measuring system is presented for application in harsh environmental conditions, i.e. to detect carbon monoxide and oxygen at temperatures of up to +225°C and high relative humidities up to 95%. The gas sensors are fabricated using SOI high temperature technology and two full custom ASICs are embedded into a high-temperature circuit board interfaced to a low-cost general purpose microcontroller. The sensor system has been developed for a CO concentration range of 0 to 300ppm, O₂ concentration range of 0 to 21%, and monitors the humidity and temperature of the gas, as well as operating temperatures of micro-heaters within the two MOX gas sensors. Feedback control is built into the program of the micro-controller to compensate for temperature dependence of gas sensors. Preliminary experiments show promising results for the intended application within domestic boilers.

© 2015 Published by Elsevier Ltd. This is an open access article under the CC BY-NC-ND license (<http://creativecommons.org/licenses/by-nc-nd/4.0/>).

Peer-review under responsibility of the organizing committee of EUROSENSORS 2015

Keywords: gas sensor system; harsh environment; high temperature

1. Introduction

With increasing demand for environment protection and energy conservation, combustion control and optimization is highly desirable and requires better monitoring of the input and output gas concentrations in combustion reactions, such as small-scale boilers for industrial, automotive, aerospace, marine, and domestic application. In these real-world situations, sensor systems need to cope with one or more of the following extreme conditions: high operating temperature (>150°C), high pressure, significant vibration, high humidity, high radiation

* Corresponding author. Tel.: +44-(0)-2476523695.
E-mail address: J.W.Gardner@warwick.ac.uk

levels, aggressive media (corrosive, toxic, explosive), electromagnetic spikes; these conditions may be described as a harsh environment [1]. In general, traditional sensors cannot survive in harsh environments for a long time because of failure within the sensor, inside the packaging, or at the interconnection between the sensor and electronics. Special sensors are being studied and designed to adapt to harsh environment applications, such as temperature sensors [2, 3] and gas sensors [4, 5].

Based on an EU project called “SOI-HITS”, special gas sensors and temperature sensors based on SOI high temperature techniques, two full custom ASICs called Read Out Interface (ROI) and Generic Sensor Interface (GSI) are manufactured by commercial partners. All components are embedded into a high-temperature circuit board and a low power, small size gas sensor measuring system is designed and constructed for the purpose of combustion optimization. The system comprises a low cost and general purpose Freescale Freedom KL25 microcontroller board connected to a 4-layer interface board designed for the sensors and specific ASICs as well as the auxiliary circuits.

2. System design and realization

2.1. System design

A block diagram of the gas sensor system is shown in Fig. 1. Sensors are contacted through an interface board, acquired and controlled by a microcontroller board and communicated with a computer.

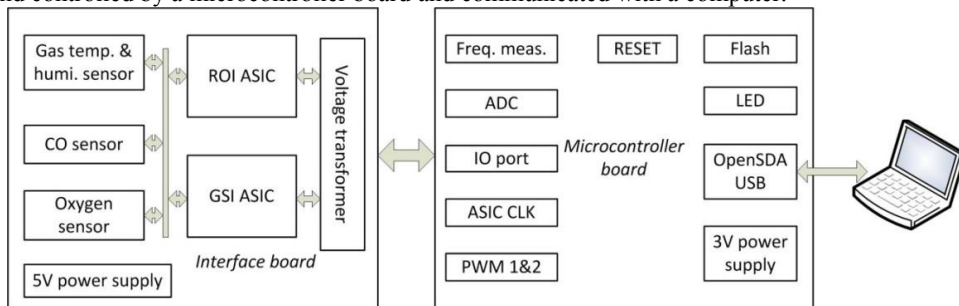

Fig. 1. Functional block diagram of the gas sensor measuring system.

A Freescale Freedom KL25 microcontroller board is employed due to its low price and high performance; it is available as a single chip implementation for high volume application. The KL25Z contains a 32 bit ARM Cortex - M0+ microcontroller clocked at 48 MHz, with on chip peripherals such as timers, ADCs and communication interface modules. Flexible I/O port configuration makes it easily adapt to the application. An interface board is designed compatible with the general purpose microcontroller board.

The micro-sensors used are based on high temperature SOI based micro hotplates [3]; each gas sensor includes a silicon diode temperature sensor. The capacitance type humidity sensor integrated with a diode temperature sensing unit, are designed to detect the humidity and temperature of target gas. The MOX type CO and O₂ sensors contain a heater, a temperature diode and a gas sensing unit in their micro hotplates. Heaters are controlled to set the micro hotplate operating at proper temperature, for example, 300°C for CO sensor, and 550°C for O₂ sensor. The temperature diode is monitored as a feedback for heater controlling in order to obtain a constant heating temperature to make sensors stable.

The ROI and GSI chips are designed to transform the signal of sensors to the detective levels and control the sensors conveniently (from Université Catholique de Louvain and CISSOID). They work in tandem but could be integrated further into a single chip.

The ROI chip contains a driver circuit to power to micro hotplate heater, a 3-channel diode biasing circuit to measure the temperature, a Z-to-f transducer which produces an oscillation frequency output proportional to the micro hotplate IDE reading and a resistive voltage divider to generate a 2.5V output for the GSI chip. It is designed to withstand a large temperature range from -55°C to 225°C. A pulse-width modulated (PWM) voltage driving circuit is designed. The pulses width controls the micro hotplate heating by joule effect in the tungsten resistance.

GSI chip contains an analogue multiplexer, a programmable gain amplifier, an anti-aliasing filter, a current reference and a voltage reference. It is programmable to amplify and acquire 4 dual channel inputs.

2.2. Real system

Two demo units have been constructed for comparison, shown in Fig. 2 (a) and (b). Fig. 2(a) is a low temperature demo unit housing sensors and ASICs together, which is only suitable for low temperature conditions up to 85°C. Fig. 2(b) shows an interface board and sensor board adaptive to high temperature conditions up to 225°C, which uses high temperature sensors, soldering paste and materials (from Microsemi). Both the two interface boards have same and compatible I/O ports and share the same electrical interconnects with same micro-controller boards embedded with same programs.

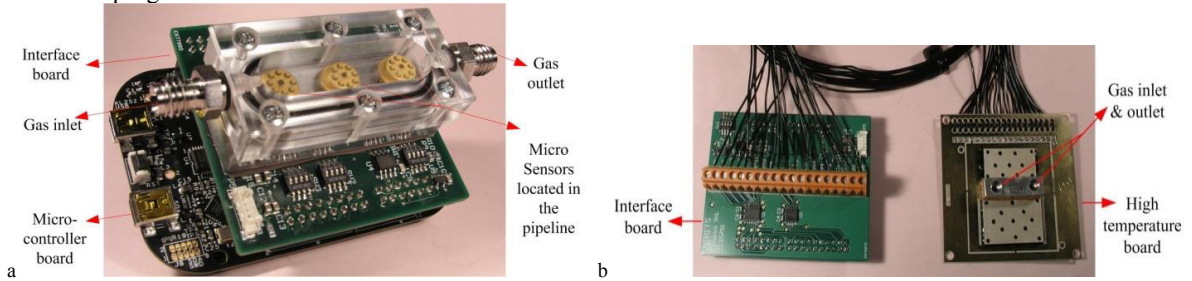

Fig. 2. (a) Photograph of the low temperature system configurable up to 85°C; (b) Photograph of high temperature system (right hand side) configurable up to 225°C.

3. System measurement

3.1. Data logging user interface

All the signals and controls can be performed with a virtual user interface realized with MATLAB installed in a computer. UART data transmission scheme is realized through the USB connection between the microcontroller and the computer. Fig.3 (a) shows the interface, which contains the plots of temperature, humidity, CO and O₂ sensor values, the PWM duty cycle updates and the received hexadecimal code of serial port.

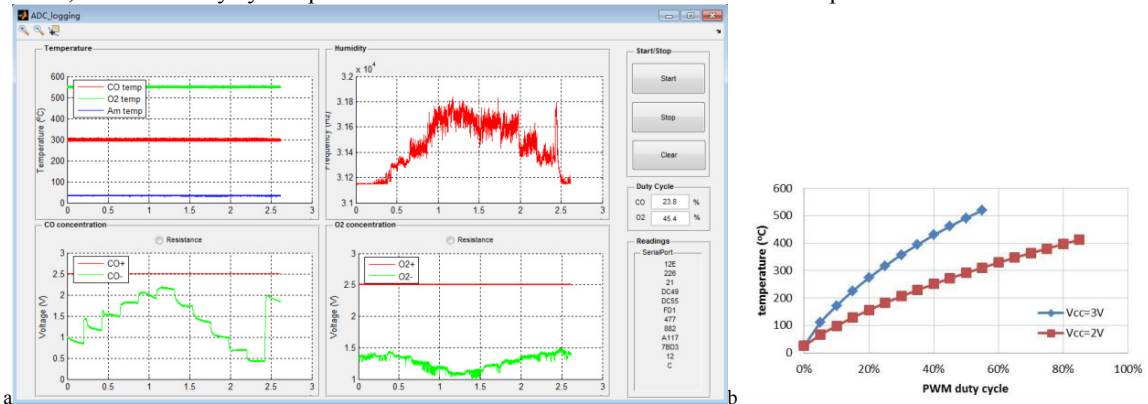

Fig. 3 (a) Test user interface displayed on PC; (b) Dependence of sensor heater temperature on PWM duty cycle.

A PWM technique is used to control the operating temperature of gas sensors, which is embedded into the program of micro controller. Preliminary measurements of the temperature dependence of PWM duty cycles at two heating voltages are shown in Fig.3 (b).

3.2. Gas test

O₂ concentration is set to 20.9% (air) - 16% - 8% - 4% - 2% - 1% - 2% - 4% - 8% - 16% - 20.9% (air). Each stage lasts 10min. Two series of tests are performed. No time interval exists between the two series. Fig.4 (a) shows the voltage response curves. From Fig.4 (a) it can be seen that the sensor shows good proportionality to the O₂ concentration and good repeatability. Sensor resistances fall into the range of 56-91 K Ω corresponding to the O₂ range of 20.9% to 1% calculated based on the load resistor.

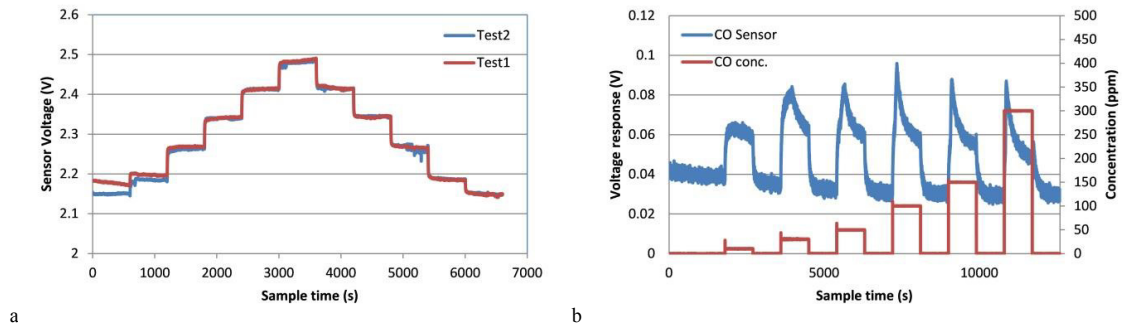

Fig. 4 (a) O₂ sensor response signal in dry air at room temperature; (b) CO sensor response signal in dry air at room temperature.

CO concentration is set to a step change in the range of 0-300 ppm. The voltage response and the CO concentration settings are shown in Fig. 4(b). Sensors are sensitive to CO at low concentration values, but saturated at high concentration values.

4. Summary and discussion

A miniature gas sensor measuring demo system is presented for application in harsh environmental conditions. Preliminary experiments have been performed based on the demo boards. Two ASICs simplify the conditioning circuit of sensors. The sensors are bonded directly onto the high temperature board, which brings time consumption due to bonding problem of replacing sensors and chips. Therefore, the high temperature experimental results will be presented in the conference hopefully.

Acknowledgements

This work is part of an EU project called “SOI-HITS” and we thank the other partners - Cambridge CMOS Sensors Ltd (UK), Honeywell (Romania), CISSOID (France), and Université Catholique de Louvain (Belgium) for the sensor components.

References

- [1] F. Udrea, S.Z. Ali, M. Brezeanu, V.Dumitru, O.Buiu, et al, SOI sensing technologies for harsh environment. IEEE 2012 International Semiconductor Conference 1 (2012) 3-10.
- [2] H. Cheng, X. Ren, S. Ebadi, Y. Chen, L. An, X. Gong, Wireless Passive temperature sensors using integrated cylindrical resonator/antenna for harsh-environment applications, IEEE Sensors Journal, 2015,15(3): 1453-1462.
- [3] A. De Luca, V. Pathirana, S.Z. Ali, D. Dragomirescu, F. Udrea, Experimental, analytical and numerical investigation of non-linearity of SOI diode temperature sensors at extreme temperatures. Sensors and Actuators A 222 (2015), 31-38.
- [4] B.J.D. Furnival, S.K. Roy, K.V. Vassilevski, N.G. Wright, A.B. Horsfall, C.J. O'Malley, CMOS compatible gas sensor arrays for hostile environments, IEEE Sensors Conference (2012) 1-4.
- [5] D. Nowark, S. Sawicki and A. Dziedzic, High temperature LTCC package for gas sensor, IEEE International Students and Young Scientists Workshop, (2010) 64-65.