

University of Warwick institutional repository: <http://go.warwick.ac.uk/wrap>

A Thesis Submitted for the Degree of PhD at the University of Warwick

<http://go.warwick.ac.uk/wrap/34803>

This thesis is made available online and is protected by original copyright.

Please scroll down to view the document itself.

Please refer to the repository record for this item for information to help you to cite it. Our policy information is available from the repository home page.

THE ISSUES INVOLVED IN DESIGNING
ESP COURSES FOR KUWAIT BUSINESS
INSTITUTE STUDENTS WITH SPECIAL
REFERENCE TO COMPUTER SCIENCE
STUDENTS.

by

Ismat Asa'd Al-Attili (B.A., M.A., English, Baghdad University).

Submitted to the Arts Education Department, The University of Warwick,
England, in Candidacy for the Degree of Doctor of Philosophy.

August, 1986.

C O N T E N T S

Table of Contents	(i)
Acknowledgements	(ix)
Declaration	(x)
Abstract	(xi)
Abbreviations	(xii)
CHAPTER ONE : INTRODUCING THE INSTITUTION AND THE PROBLEM	
1.0 The Institution : Kuwait Business Institute	1
1.1 The Objectives of Learning English by Kuwaitis and Kuwait Business Institute Students	5
1.2 The Status Quo of KBI	6
1.2.1 General Drawbacks of the Present Arrangements in KBI	12
1.3 The Nature of the Problem and the Nature of the Research	14
1.4 The Need for The Research	15
1.5 Rationale	16
1.6 General Remarks	18
CHAPTER TWO : THEORETICAL PRINCIPLES IN ENGLISH FOR SPECIFIC PURPOSES	
2.0 Introduction	20
2.1 The Relationship Between ESP and ELT	21
2.2 Definitions of ESP	23
2.3 Types of ESP	27
2.4 Historical Background	33
2.5 The Needs to Know When Designing ESP Courses	38
2.5.1 The Learners	39
2.5.2 The Objectives	41
2.5.3 The Contents	43
2.5.4 The Methodology	53

2.6	Conclusion	58
CHAPTER THREE : THE BACKGROUND FOR ESP IN KUWAIT BUSINESS		
INSTITUTE		
3.0	Inauguration of Kuwait Business Institute	63
3.1	Division of KBI Life Span	64
3.1.1	The First Stage	65
3.1.1.1	The Lack of Proper Needs Analysis	66
3.1.1.2	Kernel Lessons Intermediate	67
3.1.1.3	Dissatisfaction of Teachers and Students	68
3.1.1.4	Felt Need for ESP and Constraints	69
3.1.1.5	Output of the First Stage	70
3.1.1.6	Supplementary Materials	70
3.2	The Second Stage	71
3.2.1	The Developing English Department	71
3.2.2	Introduction of Placement Examination	71
3.2.3	Introduction of Kernel Lessons Plus	72
3.2.4	Components of Each Unit	72
3.2.5	Shortcomings	74
3.2.6	Implementation	74
3.2.7	Teacher-Made Materials Courses	75
3.2.8	Constraints	76
3.2.9	The Researcher's Point of View	77
3.2.10	Details of 201 and 202 Courses	77
3.2.11	Some Immediate Responses	79

3.3	The Third Stage	80
3.3.1	Partial Achievement of Objectives	81
3.3.2	Proposed Cancellation of Kernel Lessons Plus	82
3.3.3	Cancellation of Course 202	83
3.3.4	The Changing Context of ELT	83
3.3.4.1	Advantages of the Changes of Context	84
3.3.4.2	Problems Created by the Change	85
3.3.5	Rewriting of Course 201	89
3.3.6	Introduction of Materials for Medical Secretaries	90
3.3.7	Pros and Cons of Medical Secretaries Materials	91
3.3.8	Type of Materials That Should Be	93
3.4	Résumé of the Evaluation of ELT Materials Used in KBI	102

CHAPTER FOUR : TOOLS OF RESEARCH USED : QUESTIONNAIRES AND
THEIR RESULTS

4.0	Introduction	111
4.1	Nature and General Objectives of The Questionnaire and/or the Constructed Interview	111
4.1.1	The General Objectives of the Questionnaire	112
4.1.2	The Specific Objectives of Each Section	113
4.2	The Usefulness of a Questionnaire as a Research Tool	115
4.3	Why Are Employers', Teachers' and Graduates' Views Taken Into Consideration?	116
4.3.1	The Constructed Interview	117
4.3.2	Employers' Questionnaire	119
4.3.2.1	Section I	120
4.3.2.2	Section II	122
4.3.2.3	Section III	125

4.3.2.4	Section IV	128
4.3.2.5	Section V	131
4.3.3	Teachers' Questionnaire	135
4.3.3.1	Section I	136
4.3.3.2	Section II	137
4.3.3.3	Section III	139
4.3.3.4	Section IV	141
4.3.3.5	Section V	145
4.3.4	Graduates' Questionnaire	149
4.3.4.1	Section I	149
4.3.4.2	Section II	152
4.3.4.3	Section III	154
4.3.4.4	Section IV	156
4.3.4.5	Section V	159
4.4	General Evaluation of The Results of Questinnaires in Relation to Stated Objectives	163
4.5	Conclusion	167

CHAPTER FIVE : TEXT ANALYSIS AS A CONTRIBUTION TO NEEDS ANALYSIS

5.0	Introduction ^{FOR ESP}	171
5.1	Objectives	171
5.2	Definitions of the Words 'Text' and 'Discourse'.	172
5.3	Historical Development of Discourse Analysis	189
5.4	Approaches to Analysis	194
5.5	Computer Science Text Analysis	199
5.6	Evaluation of 'English for Computer Science'	205
5.6.1	Layout of the Book	205
5.6.2	Objectives of the Book	206

5.6.3	General Evaluation of the Book	209
5.7	KBI Computer Texts Analysis : The Method of Selection and the Books	210
5.7.1	Texts Representation of Computer Science Texts	212
5.7.2	Objectives of this KBI Text Analysis	212
5.7.2.1	The Functions Problem	213
5.7.3	Text Analysis	214
5.7.3.1	The First Text : Basic Elements of a Computer	216
5.7.3.3	The Communicative Functions Realised in the Text	218
5.7.3.3	The Second Text : The Computer as a System	222
5.8	Salient Points	226
CHAPTER SIX : THE CONTRIBUTION OF CLASSROOM LECTURES AND CLASSROOM DISCOURSE TO NEEDS ANALYSIS		
6.0	Introduction	230
6.1	Teaching, Learning Harmony	231
6.1.1	The Ability to Learn and Individual Differences	232
6.1.2	Successful and Unsuccessful learners	232
6.1.3	Eclecticism	233
6.1.4	Attending to the Needs of Students, Teachers and Employers	234
6.2	Objectives	235
6.3	Analytical Approaches to Lectures	345
6.4	6.3.1 Listening to Lectures	236
6.3.1.1	Style 'A' - Reading Style	236
6.3.1.2	Style 'B' - The Conversational Style	237
6.3.1.3	Style 'C' - The Rhetorical Style	238
6.3.2	Lecture and Text	239
6.3.3	Classroom Discourse	240

6.3.4 Spoken and Written Discourse : A Practical Approach	241
6.3.5 Candlin and Murphy	245
6.3.6 Brown and Yule	245
6.3.7 Chaudron and Richards	246
6.4 Significant Elements in Lectures	249
6.5 KBI Computer Science Lectures	250
6.5.1 Objectives of this Section	250
6.5.2 Materials	250
6.5.3 Subjects	251
6.5.4 Procedures	252
6.5.5 Importance of Lecture Analysis in ESP	252
6.6 A Lecture as A Communicative Event	254
6.7 The Representation of the Sample to Their Population	256
6.8 Lecture Analysis	256
6.8.1 The Overall Organisation of the Lecture	256
6.8.1.1 The Information Content of the lecture	258
6.8.1.2 Macro-markers	261
6.8.1.3 Micro-markers	262
6.8.1.4 Functions Realised in the Lecture	263
6.8.1.5 The Recurrent Structural and Lexical Items	267
6.8.2 Almkbil's Lecture	269
6.8.2.1 The Overall Organisation	269
6.8.2.2 Macro-markers	274
6.8.2.3 Micro-markers	275
6.8.2.4 Functions Realised in the Lecture	275
6.8.2.5 The recurrent Structural and Lexical Items in the second lecture	277
6.8.3 Almahmeed's synopsis	280
6.8.3.1 The overall organisation of the synopsis of the third lecture	280

6.8.3.2 Macro-markers in the synopsis	282
6.8.3.3 Micro-markers in the synopsis	282
6.8.3.4 Functions realised in the synopsis	282
6.8.3.5 The recurrent structural and lexical items in the synopsis	284
6.9 The Contribution of the Analysis of Classroom Lectures and Classroom Discourse to a Broad Needs Analysis	285
6.9.1 Features of the English Language used in oral communication in KBI Computer Science Lectures	286
CHAPTER SEVEN : CONCLUDING THE RESEARCH	
7.0 The Problem of Needs Surveyed	291
7.1 The Purpose	293
7.2 Bases for ESP Courses	296
7.3 Content	299
7.4 Methodology	299
7.5 Other Pedagogical Issues	300
7.6 Teacher-Training	301
7.7 Conclusion	302
7.8 Suggestions for Further Research	303
Bibliography	305

APPENDICES

	Pages
A - Syllabus for the Teaching of English at the Commercial Institute. 1975.	318
B - Questionnaires	326
B1 Employers' Questionnaire	326
B2 Teachers' Questionnaire	332
B3 Graduates' Questionnaire	338
C - Computer Science Texts	344
C1 Basic Elements of A Computer	344
C2 The Computer as A System	351
D - Computer Science Lectures	373
D1 Sartawi, Z's Lecture	373
D2 Almukbil, A's Lecture	381
D2* Almukbil's Handwritten Lecture	388
D3 Almahmeed, A's Handwritten Summary of his Lecture	395
E - Computers and Their Uses in Kuwait.	400

ACKNOWLEDGEMENTS

The researcher likes to express his gratitude for all those who extended any sort of help to him before and during the process of preparing this Thesis.

First and foremost thanks are due to Mrs. Julia P.Khan, the supervisor, for her continuous help and her never failing attitude to do so. Lots of thanks are presented to my supervisors in the first stages of the research Mrs.T.Henderson for her insights and directions to recent issues relating to my research and Dr.D.Atkinson for her help and readiness to help when promptly called on. A bundle of thanks, the researcher offers, to Mrs. Jean Ensley for her help. The researcher also thanks his colleagues at the Kuwait Business Institute. A calabash of thanks is also due to Miss Fawzia Alnafisi, the Director of Kuwait Business Institute for her initiative and recommendation. The researcher also acknowledges the help of his colleagues in the Computer Science Department, Messrs, Ahmad Almahmeed, Adnan Almukbil and Zahir Sartawi, who offered every possible help to get access to their lectures and record what was necessary for the purpose of the Thesis. Thanks are extended to Julian and Melanie Pheby and to everybody who shared in answering questionnaires and/or constructed interviews pertaining to the research. Bundles of thanks are offered to the researcher's family, wife, daughters Haneen and Alaa and sons Aghlab and Furat who willingly sacrificed so much of their time for the researcher and helped to create a suitable atmosphere for him to successfully carry out the task.

Finally, the researcher thanks the Librarian, in charge of Westwood, Pat Avann and all the staff for their great help. Thanks are also due to Mrs. V. Ward who has put the script into its final shape.

DECLARATION

The researcher hereby declares that the Present Thesis is the result of research carried out by him as included within . He also adds that it is his own work unless indicated within the body of the Thesis, and where he acknowledges it. He also confirms, this Thesis has not been submitted in candidacy for any degree other than the present one.

The Researcher

I.A. AL-Attili

The Supervisor

Julia P. Khan

ABSTRACT

This research which is about the Issues Involved in Designing ESP* Courses for Kuwait Business Institute Students with Special Reference to Computer Science Students consists of seven chapters. The first chapter introduces Kuwait Business Institute. The second offers the historical background of ESP and a survey of its theoretical bases. The third gives an account of the three stages of KBI's⁺ life span along with a critical appreciation of the English language teaching materials used. The fourth presents questionnaires and constructed interviews used in identifying needs of employers, teachers and graduates and expounds their results. The fifth presents approaches to text analysis and a functional analysis of two chapters selected from two textbooks used by KBI computer science students. The sixth goes into the classroom with computer science teachers and students and presents an analysis of three lectures by three computer science teachers. The last chapter presents conclusions from a synthesis of findings. The findings call for the rejection and replacement of current English Language teaching materials. They also support a broader needs analysis. This should include views, concerning demands made by the language of the computer science academic courses content, of teachers, students and employers. It should also include the results of text analysis component of the relevant academic courses content. Recommendations and suggestions for further research when designing ESP courses for KBI computer science students in particular and students of different specialisations in general are made.

*ESP - English for Specific Purposes

+ - Kuwait Business Institute.

KEY TO ABBREVIATIONS

ALU	-	Arithmetic Logic Unit
CPU	-	Central Processing Unit
E's	-	Employers'
EAP	-	English for Academic Purposes
EEP	-	English for Educational Purposes
ELT	-	English Language Teaching
EOP	-	English for Occupational Purposes
ESP	-	English for Specific Purposes
EST	-	English for Science and Technology
GPA	-	General Point Average
GPE	-	General Purpose English
GCCC	-	Gulf Countries Co-operation Council
G'S	-	Graduates'
I/O	-	Input/Output
KAAU	-	King Abdul-Aziz University
KBI	-	Kuwait Business Institute
KLI	-	Kernel Lessons Intermediate
KLP	-	Kernel Lessons Plus
MS	-	Medical Secretaries
PAAET	-	The Public Authority for Applied Education and Training.
T's	-	Teachers'

CHAPTER ONE

INTRODUCING THE INSTITUTION AND THE PROBLEM

1.0 The Institution : Kuwait Business Institute - KBI

Kuwait Business Institute - KBI is a government Applied Education Institution sponsored completely by the State of Kuwait. It is governed by a board of directors selected from within and from outside the Public Authority for Applied Education and Training according to certain bylaws in its ¹statute. This board of directors is usually selected from three sources according to merit and relevant activities. Members of the board include university professors, private cum public sector employers, a director from KBI and the General Director of the Public Authority for Applied Education and Training - PAAET. All these are headed by the Minister of Education as Chairman of the Board.

KBI is two institutes in one, one for men, another for women on separate sites and both are generally run by a director assisted by two assistant directors for Academic Affairs, on both sites. One administrative and financial deputy is responsible for administrative and financial affairs on each site but there is only one assistant director for registration for both institutes for men and for women.

Four main specialist departments of Business Administration and Secretarial Work, Accounting, Insurance and Banking and Computer

1. Amended Statute of KBI. KBI 1983. Kuwait

Science offer their courses to the student population of 2331, as in the first term 1984-85². This population consisted of 946 men and 1385 women at that time.

One department may have one or more sections as with Insurance which has a banking section. Similar to that is the Department of Business Administration and Secretarial Work which has: Business Administration, Medical Secretaryship, Materials Management, Co-operatives and Posts Sections. Many non-specialist Departments do take part in the teaching and training processes i.e: English Department, the Business Law Department, the Statistics Department, the Economics Department, the Typing Department, the Office Practice Department and the Field Training Department.

A registration section in each of the Institutes handles registration, graduation requirements, test results, record-keeping and other relevant matters.

All the departments, whether specialist or service ones, contribute to the teaching-learning and training processes that are usually provided by the Institute.

The Institute - KBI was officially inaugurated in September 1975, following a study of the need for such an institution, conducted by a committee of experts in technical and vocational education headed then by the Director of the Technical and Vocational Education Department of the Ministry of Education. The study, as indicated by the Report,³ stressed the need for parallel and alternative

2. Taken from a survey carried out by the registration sections at KBI on 15.10.84

3. Parallel and Alternative Education, Report submitted by W.Bonnyrust to the Ministry of Education - Kuwait 1974.

channels of applied education comparable with that branch of theoretical study at a university. The objectives of this study were whether to supply vocational and technical education and training to school leavers so as to create a national technical workforce in commercial and in business fields which will also help to create a good Kuwaiti citizen.

The objectives of the Institute, as laid down in the Statute, were to provide the local market with trained national manpower in business administration, secretarial work, accounting, insurance and underwriting, banking, computer operating and programming. The trained and scientifically based national manpower is aimed at providing the local market with officials for medial jobs in the aforementioned fields. These were short term objectives. In the long run the objectives differed; they aimed at creating national manpower to take over jobs currently occupied by expatriates, to form stable and scientifically-trained manpower, to avoid a one-sided national economy by creating job opportunities and to help in creating a balance between the **native** population and the incoming job seekers.

There were four English courses offered at the beginning. They were offered as common, complementary yet compulsory courses for students of all specialisations. Courses 101 and 102 served the first and second term students respectively. These belonged to the first year of study. The other two courses, named 103 and 104 at the beginning, belonged to the second year of study and were allocated for third and fourth term students respectively. Each course was allocated two credits which made up eight credits for the English Language Courses taught at KBI.

The English Language Courses offered at KBI were then cut down to three after having undergone change in their numbers; thus becoming 101, 102 for first-year students and 201 and 202 for second-year students. The last course, 202 was dropped. A non-credit remedial course, 099, was added.

Though there was a cancellation of the fourth English Course, 202, for most specialisations, it was not applied to the Medical Secretaries Specialisation as was envisaged by the Academic Affairs Committee in 1978. As claimed by the head of Business Administration and Secretarial Work Department and approved by the Academic Affairs Committee, the fourth English course need not be cut off from the Medical Secretaries specialisation. So in all the specialisations the English Language credits ranged from 6 to 8.

The cut down in the English Language course was dealt with in another way. Subject-specific courses in all specialisations were introduced. The credits allotted for such courses ranged from 3 credits in Insurance to 9 in Computer Science. They were credits for courses taught through the medium of English by subject specialists and not by English Language teachers. A two-credit course in Business Correspondence is usually taught for the students who decide to take it. A six-week, four-credit period of job or field training usually comes after finishing the first year of study. It is a prerequisite for graduation. Both teachers or training supervisors from KBI and employers offering training on their premises, besides a third neutral party with relevant expertise, take part in the assessment of trainees' performance. This shows the theoretical and the applied nature of courses at KBI.

In order to graduate, a student should have, at least, obtained a standard of 1.5 as general point average - GPA - on the four point scale. Though a 1.0 GPA is a pass, it does not mean the student who obtained it or any GPA lesser than 1.5, is considered on the graduands list. He has to improve his GPA through repeating some courses and thereby obtaining higher scores to qualify for graduation. Indeed all students are required to pass the 68 credits each as required by his department.

Diplomas were conferred on the first group of graduates in June 1977. Most of the graduates followed up their former careers and others started their careers in the fields they were taught and trained in.

1.1 The Objectives of Learning English in Kuwait and KBI

Kuwaiti people are in general interested in learning English as a foreign language for many reasons; as English is an International language so the Kuwaiti people wanted to learn it. They wanted to keep reciprocal ties with the English and the English language was the means of communication. They had to teach English in the school syllabuses as a school subject. They also had to communicate with the British for commercial, industrial and technological reasons Kharma (1977:103-11). English served them as a means of communication and a carrier of information. A minority studied English Literature at universities (Swales 1984: 4-5). Some needed to pursue the many aspects of recent advances in science. Others had to learn English for specific purposes, such as spreading Islamic thought in the Indian sub-continent. Young men and women learned English so that they could pursue advanced or specialised studies in the fields of Engineering, Science, Medicine and Technology. These and the transfer

of technology helped national development and constituted an important element among the objectives and reasons for learning and teaching English. This goes with what Brumfit (1980:6) wrote in another context:

"Some needed English for instrumental, intellectual or aesthetic reasons".

Amongst the objectives is the desire of a group of young men and women, mostly highly qualified, to settle permanently in the UK or the USA. Such learners study it for integrative purposes.

Commercial transactions have made English the unofficial second language in Kuwait according to M.K.Sawwan⁴.

1.2 The Status Quo of KBI

In KBI, where English is very much in demand, it is taught for instrumental reasons. Studying the language within such a context enables students to learn more and use foreign references. As graduates and members of the local workforce, they need it for better performance; international communication and as a means of assured promotion. The general objectives officially laid down by a committee involved in the teaching-learning process at KBI state:

General Objectives⁵

- (1) The first two (101 and 102) of the four courses should be mainly concerned with activating the entrants' basic command of the fundamentals of English. The contents of the two courses specially the latter (102) should be coloured with commercial language.
- (2) The remaining two courses should be concerned with preparing the students to perform competently in such situations as they are liable to meet with both in their specialised (commercial) studies and later in their jobs.

-
4. M.K.Sawwan 'A Lecture on the Status of English in Kuwait' April 1986
 5. Syllabus for the Teaching of English at the Commercial Institute, KBI, 1975.KBI

Whether these objectives are satisfactory or were carried out as pre-planned, we will debate throughout the thesis. We will also try to prove the necessity of what we believe to be the proper issues to be involved in the design of English for Specific Purposes Courses, ESP, at KBI in general and for Computer Science students in particular.

The four English Language courses previously mentioned had their specific aims which refer to refreshing students' basic command of English, utilisation of certain structures, skills, functions and establishment of links between general English and ESP. Of the means of achieving these aims, no further elaboration was mentioned in the English Language Syllabus. Developing teaching or wishing to teach a foreign language, for example, English Language, should have at least, a satisfactory scheme of work, course design, suitable materials, content, and the suitable means of implementing it, the methodology. Thus a student at KBI should know or at least be guided as to why he studies English at this stage and how that could be carried out; whether for integrative reasons which are out of place at KBI or instrumental ones which form, at least now, the true justification. The content of courses should be both relevant and motivating. The method or approach to be implemented should be clear to the teachers. This would eventually affect teacher-student motivation. Four major factors, the researcher thinks, should be taken into consideration before embarking on designing any course for any kind of learners at KBI.

- (a) Learners. Their background, age, nationality, motivation, culture as well as their researched needs should be considered.

(b) Objectives of learning the language aimed at.

(c) Materials or content of courses, whether ESP or General Purpose English, GPE, or English for Survival or Remedial purposes or otherwise.

It will, then, be left for the institution concerned to see the best possible way for application.

(d) Methodology provided suitably in context. This refers to the method or approach adopted in teaching the English required according to objectives, be it communicative or otherwise.

Concerning learners or students at KBI, they are mostly Kuwaitis, adults who have had their General Secondary School Certificate or any other equivalent certificate in parallel education. The mean age of entry differed according to the stages of the KBI life span mentioned in Chapter three. The stages, the researcher envisages are developmental ones. In the first it was 18-40 years. Such a big gap, then, narrowed down a little and became 18-35 in the second. The latest mean is 18-25 which is the normal one if we take into account the age of entering school which is usually six, the duration of school life which is twelve years and a few years of lagging behind since the quality of students who usually join KBI is not the best. The percentage of Kuwaiti students in the group of learners at KBI is 85% according to the officially announced policy of admissions. The other fifteen percent is divided into quotas for scholarships, expatriates and Gulf Countries Co-operation Council, GCCC, students. As for expatriates wanting to get admission they should have finished school in Kuwait, which contributes to the homogeneity of learners. Their educational background is that of learners who have been through general

secondary school syllabus. Through the last eight years of schooling, English is taught as a school subject. The academic year is of seven months duration with English having six to eight periods of 45 minutes a week. The English taught could be categorised as General Purpose English - GPE. Such students, school leavers, form the normal input for KBI.

The students' motivation is, comparatively speaking, moderate as they did not obtain high enough marks to allow them places at Kuwait University or any other high prestige university. This also applies to their level of competence in English. They are mostly Moslems. So any course designer should bear this in mind for implementation purposes when setting out to perform his task.

As for objectives in learning English, the ones found in the 'Syllabus for the Teaching of English at the Commercial Institute' meaning KBI (1975:1) stated - two main objectives for all courses (see 1.1) plus specific aims for each of them.

The objectives were laid down by **an advisory committee** in 1974. 'For the first three courses, meaning specialisations in, Accounting, Business Administration and Secretarial Work and Insurance, the four skills- listening comprehension, speaking, reading and writing should be given equal weight. For the fourth course, **namely** Computer Science Specialisation the main interest will be concerned with listening comprehension and reading in the specialised field of study'.

Each course, here English course, has been allocated two pages including:-

- (a) List of structures; and
- (b) Skills and Functions.

As for point (a) of the specific aims (a) - List of Structures, this has mostly been copied from the first half of Kernel Lessons Intermediate - KLI, meanwhile the other half served the second course, 102, then.

All the courses have had their share of the functions to be taught. Skills have been mentioned altogether with functions. Mentioning the fourth course, then named 104, the main objectives cited read as follows:-

"The main interest of the courses for each of the four specialisations should be a concentration on the application of the structures and functions of the first three courses (101, 102 and 103). Therefore no attempt has been made to provide either lists of structures or functions.... However, for the computer science specialisation, interest should be given to listening and reading comprehension." 6

The general objectives referred to and quoted in 1.1 will appear in Appendix A. The first talks of two points under number 1. The point of mastering the basic structures found in Appendix 1 of the Syllabus referred to or rather activating the command, as if students of KBI had that sort of what may be called command of the basic structures. To realise that, students were referred to Kernel Lessons Intermediate by O'Neill - KLI; which does not contain the complete list of structures. Neither does it contain all the items suggested.

6. P.5 Syllabus for the Teaching of English at the Commercial Institute, April 1975.

The other refers to the content which should be coloured with commercial English. This means the lexical side and this again was not clearly pointed out, not even partially spelled out, which we will discuss later in ESP materials, discourse analysis and classroom interactions. Regarding methodology no mention of that has been traced except what we surmise when we read 'list of functions' in the syllabus. This will also be discussed later. The committee want to give the four skills equal weight which is not fair to students. If it were feasible for one course, it would not be so for the other.

When they come to computer science specialisation, they give prominence to 'listening and reading', as if KBI students were all to pursue their higher studies, learn English for Academic Purposes or EAP which is not true with the majority of Computer Science graduates. As far as the researcher knows, there have been no listening materials for Computer Science students. This clearly shows that what is stated is one thing and what is practised or may be achieved is another. Functions were rarely tackled except in form filling and in occasional situations and not for computer science students. Neither has the syllabus been structural nor functional. The students and their teachers suffered. Some complained they were teaching translation. There were no unified approaches or methods to conform to, neither concerning teaching methodology nor concerning writing materials. The results of the questionnaires to be used for the thesis will tell us about the skills and the focus of emphasis. The materials some courses offered lacked progression, proper content and even were like patchwork.⁷

7. Abul Fetouh, H. External Examiners' Report in 1984.

This naturally lead to a poor output. What made things worse for computer science students is that they were required to follow up instruction in English having only studied a four page topic about computers which made a very tough job for them. Half the staff members were native speakers. Students suffered from difficulties and frustration ensuing through lack of competence with reference to English. How will the students understand what native speakers say if they, till then, have not obtained a command of even the basic structures? The case was the same concerning functions. They have not been exposed to instruction in English. They have not been taught ESP proper, nor have they learnt it as English for Occupational Purposes, EOP, their main target as is stated in the objectives. In a nutshell, the courses as a whole did not supply what the researcher believes to be the true contribution to the issues he will tackle in the following chapters regarding the necessity of researched needs, linguistic, functional, pedagogical communicative, pragmatic, and, recently, political issues while studying and at job sites. This will also tackle the issues of course design that the researcher believes will supply suitable courses for a better and most convenient KBI output in general and for computer science graduates in particular. Kernel Lessons Intermediate and Kernel Lessons Plus besides all written ESP oriented materials that we will examine in later chapters especially in chapter three, now supposedly, prove no match for target materials aimed at. They, as we shall see in later chapters, pose no threat to what we would like to have as target materials for KBI English Courses.

1.2.1 General Drawbacks of the Present Arrangements in KBI, The first drawback is the departure from KBI Statute and bylaws concerning

employing highly-qualified teachers of English, holding M.A's and PH.D's⁸ in English preferably with educational qualifications. Novices are usually recruited from both Kuwaiti and non-Kuwaiti nationals. The result of such departure from rule is usually detrimental, for such a situation can never give the best results.

The second is the wish of the Public Authority - PAAET - to apply any published materials in preference to teacher-made locally - based materials. This lays an extra burden on the shoulders of fully time-tabled teachers who have to adapt materials to their purposes. It is too difficult to accept the published materials in the case of their having culturally unsuitable content. In fact such materials may not conform to proper needs analysis as we will contend in Chapter Three.

The third is the sudden changes in key positions which are sometimes made, without prior notice being given, a practice which means that the language policy of an institution is interrupted. Continuity of practice is necessary if teachers are to work confidently.

The fourth is that of technical and administrative difficulties which arise due to not having suitable physical space e.g. for the language laboratory and its technical facilities.

The fifth is the instability of the region due to the Iraq-Iran war and the recent fluctuation of crude petroleum prices; both of which led to cuts in spending and to freezing or even cancelling certain relevant programmes. Prefabricated classrooms and increased loads

8. KBI Statute, Amended 1983.

for teachers are evidences of this. One cannot imagine such classrooms in one of the very few countries that enjoys a very high per-capita income.

The sixth is the lack of motivation for teachers at KBI compared to those working for institutions of similar status. There are no systems for academic research and no leaves whether sabbatical or otherwise. This does not result in what is called job satisfaction.

1.3 The Nature of the Problem and the Nature of the Research

It seems to the researcher that little has been accomplished in the output of KBI regarding English, arguably as a result of the fact that the same English Language Courses have been taught to students of different specialisations. The researcher, who has been teaching English for the last nineteen years, eleven of them as teacher of English at KBI, is of the view that the English Language courses that have been taught have not yielded the desired result. The latest criticisms have come from several people in Business and Banking fields who have reiterated their dissatisfaction with graduates' achievement as members of the Kuwaiti workforce. They related their dissatisfaction mainly to unsuitability of English courses. Teachers of English and other disciplines also felt a sort of gap that should be bridged. What was taught was not completely relevant or it had not been meant for KBI students of different specialisations. "We prefer KBI graduates to Kuwait University graduates. Yet we want them to have studied English Language courses that are relevant to Business. We want them to have more practice in ESP English"; Commented Mr. A. B. Al-Yasin.

9. A lecture by Mr. A. B. Al-Yasin, December 1984. 'What we Want from KBI Graduates' Mr. Al-Yasin is the Chairman of the Board of Directors of the Kuwait Finance House.

This study attempts to analyse the English Language courses taught at KBI and take into consideration the basic needs of KBI students in general and computer science students in particular for the aim of showing the basic issues that should be involved in designing proper ESP courses for KBI students. This, as a result, will give sufficient bases for the rejection of the presently-taught English Language courses and the adoption of new ESP course design on justifiable bases.

The researcher contends that the issues previously involved in course design and/or adoption did not take sufficiently into account the demands of the local KBI scene. The researcher also asserts that certain steps should be followed or implemented so as to help achieve optimal needs analysis and subsequently efficient course design. The fundamental issues this research will discuss are those involved in designing ESP courses for KBI students so as to meet the needs of its clientele in respect of English Language Courses. The researcher supports the idea of locally-designed English Language courses for specific purposes after carrying out the necessary research relating to needs analysis and other relevant issues including researched needs for courses based on relevant or subject-specific content, to the courses to be designed.

1.4 The Need for the Research

After eight years of application of materials both previously published or specially written with KBI students in mind, the researcher has come to the conclusion that research into the issues involved in designing ESP courses for KBI students should be carried out. It should include issues relevant to all students or graduates,

teachers or educators and current or potential employers. These entail studying the students' background, various aspects of materials, linguistic, subject-specific, pragmatic methodology, analysis of texts, classroom interactions and observations and issues of students' future careers. The research will prove that the materials currently used are not commensurate with needs and do not satisfy the objectives of English Language courses.

The tools of the research which will be discussed in more detail in Chapters 4, 5 and 6 are diversified. Some of them are theoretical and others are applied. The theoretical range from critical survey of the English Language courses, methods or approaches to ESP theoretical issues to be met in Chapters Two and Three. The applied start with a questionnaire directed to students and/or graduates, teachers of English at KBI, also those of different disciplines and to employers of KBI graduates or potential ones; in Chapter Four. Another is text analysis of some texts taken from books nominated by KBI teachers and students and/or Computer Science graduates in Chapter Five. The third is classroom observation and analysis of recordings of classroom lectures and relevant interactions with Computer Science students in Chapter Six.

1.5 Rationale

The English Department at KBI has recently undergone effective changes in both liveware and software. What we refer to as liveware is the group of personnel involved in teaching EFL and ESP to Business students, such as teachers and laboratory assistants. That of software refers to programmes or courses whether previously published abroad or specially prepared or locally written with KBI students in

mind. In Kuwait as in other countries, the search for the most suitable resources has been going on. This was clear in the replacement of Kernel Lessons Intermediate, KLI by Kernel Lessons Plus, KLP, and by the modification carried out on other courses. The replacement (see Chapter Three) could simply be described as directed to benefit students of higher standard than the previous ones according to O'Neill (1973). All KBI English Language courses have undergone certain changes in the seventies and eighties.

When KBI was inaugurated, teaching began being mainly based on the Structural and Modified Structural Approach. Then it was shifted to what was claimed to be communicative language teaching, which we will deal with in the next and later chapters in more detail. Many books like KLI, KLP and First Things First, were used at KBI, whose students study various specialisations and for more than one year. This, it will be argued, does not appropriately correspond to a student's researched needs; b- specialisation; c-external context or place of work after graduating from KBI and joining the local workforce. Yet it should be mentioned that seeds for further change and development in English Language Courses were sown sporadically. That change was not done either according to students' researched needs or to their relevant context or specialisations. The English Language Courses as described did not meet the general requirements of the KBI graduates, educators, planners and future employers.

This research investigates the suitability of currently taught or involved English Language courses at KBI and those that should be, whether in the communicative context of subject-specific courses,

previously-published textbooks or specially cut-and-tailored English for Specific Purposes Courses and the issues involved in designing them.

1.6 General Remarks

It has been noticed that there is:-

- (a) a lack of understanding of background issues like who, what, how much to teach, where to start in teaching and whether to complement previous teaching or start right from the beginning, independently.
- (b) a lack of obviously laid objectives for teaching and learning English.
- (c) a lack of proper needs analysis to be carried out to specify the needs of learners accordingly.
- (d) a lack of the adoption of an explicit policy to follow and implement for better output.
- (e) a lack of proper text or discourse analysis as a means of gaining access to subject-specific content in order for teachers to be able to identify language demands for their students.
- (f) a lack of proper training of students in English and in the relevant fields of specialisation.
- (g) a shortage or inadequacy of available teaching resources for developing the students' skills especially listening.

- (h) a lack or inadequacy of suitable teacher-training to help achieve optional output.
- (i) a lack of progression in certain courses which complement each other or otherwise.
- (j) unacceptable cultural orientation that should not be included in English courses for KBI students. Including such aspects cuts short the time allocated for other relevant and acceptable materials and activities.
- (k) a lack of efficiency by the writers of courses which leads to similar output of students unsuitably trained in writing.
- (l) a little reference made to the utilisation of relevant communicative functions
- (m) a dissatisfaction of some employers with KBI graduates' standard **especially** the computer scientists.

In the next chapter the researcher will give a survey of ESP; background, relationship with EIT, definitions and different types of ESP in order for him to be able to elaborate on such issues for the purpose of suitable needs analysis leading to suitable course design for KBI computer science students.

CHAPTER TWO

THEORETICAL PRINCIPLES IN ENGLISH FOR SPECIFIC PURPOSES

2.0 Introduction

'English is an international auxiliary language. It is yours (no matter who you are) as much as it is mine (no matter who I am). We may use it for different purposes and for different lengths of time on different occasions but nonetheless it belongs to all of us.' (Smith L. 1976:38-42)

The status of English in foreign language teaching has been undergoing change through differences in approaches, materials and orientations. Approaches and methods in English Language teaching have ranged from the time-honoured Grammar-Translation, the Vocabulary list or Service list, the Structural Approach, the Modified Structural Approach, the Aural-Oral-Audio-Lingual-Approach, the Transformational Generative Theory's limited impact, the Direct Method, the Notional-Functional Approach to the recently advocated Communicative Approach. (See Chapter Three for more elaboration).

These were some of the approaches and methods adopted in English Language teaching in many countries of the world and Kuwait is one of them. Some other approaches could be added to them like those of self-teaching, computer-aided teaching and suggestopedia. It has been noticed that a communicative methodology has accompanied the adoption of any ESP approach to English Language teaching. It could, in fact, be argued that communicative methodology and ESP have to some extent developed concurrently and with a degree of cross-fertilisation.

What the researcher will do in this chapter is to give a survey of ESP, its background, definitions and types. These issues,

the researcher believes, will help him in trying to establish his suggested point of view of there being a different sort of needs analysis to be carried out if suitable courses for KBI computer science students are to be proper ones.

2.1 The Relationship between ESP and ELT

Diversified aims lie behind any method or approach in teaching English such as teaching it to pupils on a school syllabus. This is considered a branch of General English Language Teaching. Teaching it for Special purposes, which has recently been replaced by English for Specific purposes, is for another aim. But it is still considered within the circle of English Language Teaching. It is as Sinclair, quoted by Crocker (1981:12), put it:-

"ESP - Language for Special Purposes-...is not a branch line or a specialised interest - it is simply language teaching of any kind placed in relation to its context".

It has long been general English Language Teaching - ELT - which occupied so much time in school and college courses. It has sometimes been called General Purpose English or GPE for short. As far as ESP is concerned, we can say that it has acquired a worldwide publicity in the recent few years. Strevens (1977:90) wrote:-

"Broadly defined ESP courses are those in which the aims and the content are determined, principally or wholly, not by criteria of general education as when English is a foreign language subject in school but by functional and practical requirements of the learner".

Strevens refers to the fact that the content of ESP Courses is determined by the need of ESP learners; that is that it should consist of materials from or within their specialisations. To the financiers,

industrialists, educationists and executives due homage should be paid for their role in promoting ESP status, which, of course, serves their needs and inclinations.

As English is an international language, it is very much in demand in general Education, Commerce, Industry, Banking, Insurance, communications and for scientific and applied technological purposes. The need or demand for ESP has been noticed as usually emerging after the learner had obtained basic knowledge of general English. Many employees in Business, Banking or Insurance enterprises with computer departments consider the knowledge of English as an asset for getting higher positions. A more specialist knowledge usually leads to better achievement by students in higher or advanced studies. It is an assured promotion or at least a guarantee of position along with easy access to key positions.

In fact specific purpose English Language learners differ from general-purpose English Language learners in several aspects such as the formers' knowledge of a certain amount of general-purpose English and their need to develop that knowledge to be commensurate with their needs and aspirations. Thus needs and purpose are fundamental to the context of any ESP course as opposed to the much limited GPE range. The knowledge of the language system and structure was directed towards fulfilling the needs of the ESP learners. So the communicative methodology was brought into use in language teaching hand in hand with ESP, making it more beneficial and motivating. Yet to the researcher both GPE and ESP are nodes of ELT.

2.2 Definitions of ESP

Many practitioners have contributed a lot of information to the field of ESP. Some supplied us with their definitions of ESP. It is worthwhile referring to some of these.

Lewis Kerr (1977:11) referred to it as English for Special Purposes. He emphasised the purposes the learner needs English for as partly social needs, partly special subject needs and the other part goes for the study skills methods.

Mackay and Mountford (1978:2) wrote:-

"Languages for Special Purposes....is generally used to refer to the teaching of English for a clearly utilitarian purpose. This purpose is usually defined with reference to some occupational requirement...., or vocational training programmes...., or some academic or professional study".

The researcher agrees with Mackay and Mountford as to the purpose. For them ESP is different from ELT in that it is associated with samples of language taken from subject-specific sources (op cit:5) We also agree to this issue of subject specific materials and will elaborate on it further in Chapter Six.

Munby used the term English for Specific Purposes, not for Special purposes as Mackay and Mountford did. Mackay then in later Publications changed it to English for Specific Purposes (1981). Learners' needs and specificity of purpose are emphasised. For P.Robinson (1980:2) 'Quintessential ESP means:-

"Materials produced for use once only by one group of students in one place at one time".

She then quoted Mackay's definition of ESP:-

"It (ESP) is generally used to refer to the teaching/ learning of a foreign language for a clearly utilitarian purpose of which there is no doubt".

It would be very difficult to dispute the intrinsic validity of this definition of ESP. Practical considerations and pedagogical context may of course prevent the implementation of such a pure approach. Such an approach to teaching is:-

- (i) very demanding;
- (ii) time-consuming;
- (iii) implying that materials cannot be tried out before they can be applied, judged or valued; and
- (iv) to be pragmatic not idealistic as to be used once and for one single group of students.

There would be no harm in the utilisation of existing materials in an institution while carrying out revision or developmental measures on them. This could be done with the materials already produced-once produced - to cope with the special or specific purpose they were originally produced for.

Stevens used a different nomenclature. It is that of 'Special-Purpose Language Teaching and so it was 'SP - LT'. It is this special purpose, the specific content and the needs which made it different from GPE.

Brumfit's definition quoted in P.Robinson (1980 :11) is:-

"...an ESP course is directly concerned with the purposes for which learners need English, purposes which are usually expressed in functional terms".

Brumfit's definition goes with the main stream. It means that an ESP course consists of purpose-specific material serving learners'

needs and utilising certain functions, sometimes processes, in the meantime. This can be seen in the discourse functions or processes in the disciplines dealt with. For both Stevrens and Brumfit, as for many others, communicative methodology goes hand in hand with ESP. So far, it might be worth pointing out that the definitions quoted have a great deal in common.

Kennedy C.J. and Bolitho R do not give any concise definitions. They discuss the multi-sided aspects of ESP such as its being based on:-

- (i) needs of learners;
 - (ii) being mainly taught in post-secondary school-tertiary-level;
 - (iii) servicing other courses;
 - (iv) specific subject matter of discipline it is meant to serve;
- and (v) the characteristic of its utilising the communicative approach to language teaching.

In fact, Kennedy gave his definition of ESP when he wrote (1980:118):-

"ESP is a system, to be refined certainly, which attempts as rigorously as possible, to analyse certain factors, in a learning situation and to decide to which extent those factors should influence syllabus design and the production of materials".

The needs issues that the researcher agrees to are certainly different though they agree with Kennedy and Bolitho's points in (i) and (iii) previously mentioned and take them as issues amongst others that comprise needs analysis relevant to the research being done for KBI.

Munby's definition of ESP stated at the beginning of his 'Communicative Syllabus Design' (1978:2) is:-

"ESP courses are those where the syllabus and materials are determined in all essentials by the prior analysis of the communication needs of the learners".

For Munby ESP teaching materials should be learner-centred and so should the approach. He disregards 'the teacher's or institution's predetermined preference...' but the researcher considers the learner as one of the three members in a triumvirate government. Such government should have the teacher and the institution or the employer as the other angles of the triad. They should act integratively not centrifugally to one another. The researcher also leaves it to the triumvirate government not to the learner only to decide on the proper needs analysis that should be done to arrive at a suitable course design for KBI students in general and computer science students in particular.

It is true that many groups of learners are mature enough to decide and settle on what they want to learn but the involvement of teachers, for the choice of a learning theory as well as its application, and employers for the choice of goals or objective behaviour, will surely enrich the whole processes involved. It will, indeed, make them more practical, more pragmatic and will allow them greater chances of success.

McDonough quotes the definition of the Bullock Report - a British Project. 'A Language for Life' which refers to 'study skills' and 'Language Across the Curriculum' which refer to the areas ESP tackles. It tackles 'English for Academic Purposes and 'English for Occupational purposes' in British schools.

Hajjaj (1979) discusses ESP for Science students at Kuwait University and considers it first as English for Special Purposes. Second, he considers it as catering mostly for students at the tertiary level. He then prefers manipulating functions - macro and micro or what he calls 'etic' and 'emic' in communicative teaching. For him ESP is, as usual, discipline-based or subject-specific. His approach and treatment rank high among other sincere endeavours in ESP.

2.3 Types of ESP

More than one branch grows from the tree of ESP. They can generally be taken to include English for Occupational Purposes (EOP), English for Academic Purposes (EAP), English for Science and Technology - EST. The latter two could well be put under the heading of English for Educational Purposes (EEP).

EAP is that required for study at schools, colleges and universities whereas EOP can be given anywhere or at anytime it is required for whoever asks for it or is in need of it. Whether that was while training for a job, pre-service or in-service or even for a refresher training course, it is for the parties concerned to decide that. EST can embrace both EAP and EOP where applicable. The truth that should always be kept in mind is that ESP courses in Kuwait are courses meant for learning and not acquisition. The learners are non-native speakers of English who did not pick it up, did not utilise it as a medium of instruction during school life and did not usually utilise it in everyday life issues unless certain or specific purposes arose due to extraordinary situations.

Robinson P. (1980:13) gave a sort of definition which included the ESP main types. She wrote:-

"...an ESP course is purposeful and is aimed at the successful performance of occupational or educational roles. It is based on a rigorous analysis of students' needs and should be tailor-made'. my emphasis

She, then summarised ESP courses modifying Strevens' diagram and his text as follows:-

A Summary of ESP Courses

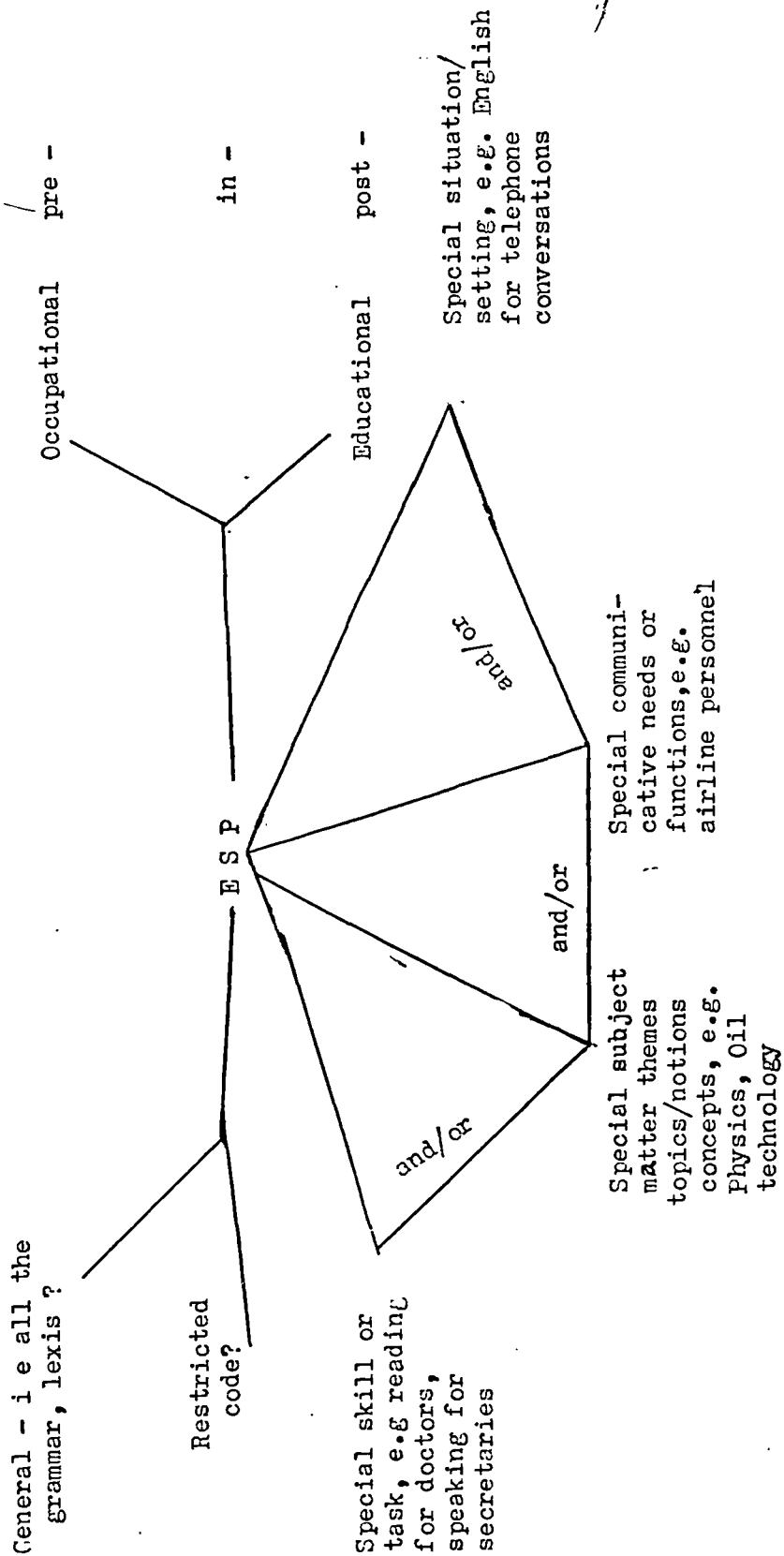

Both Strevens P. and Robinson P. lay emphasis on the special needs, the special subject matter, the special situation and, all that ensues i.e. special communication needs that require the use of special skills.

Kennedy C.J. and Bolitho R. (1984:5) also summarised ESP as being both for Occupational and Academic Purposes. They put the Occupational as having pre-experience, simultaneous and post-experience divisions. The Academic which is discipline-based is divided into pre-study and in-study. They also copied Strevens' diagram but without altering it (1984:5).

Jo McDonough (1984:6) put the diagram in a simpler form:-

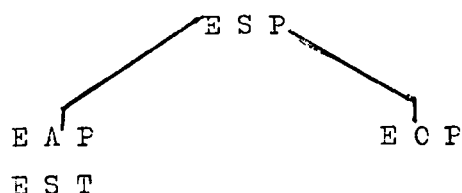

She adds that the labelling game went on e.g. English for Business Purposes - EBP. Besides, she suggested so many acronyms. In the meantime so many courses have been written for certain disciplines and have been claimed to be ESP courses. They covered so many disciplines such as English for Nurses, for Waiters, for Air Hostesses, for Pilots, for Air Traffic, for Technicians, for Secretaries, for Managers, for Doctors, for Diplomats, for Scientists etc. So many are yet to come. Take for example Strevens' 'The Language of Seafaring' and similar 'Seaspeak' courses by many others. The researcher suggests in this respect, that ESP should stand for English for Service Purposes.

The reasons behind this are multiple. English is taught for servicing other disciplines. It is not an end in itself. Houghton (1980:24-33) described ESP 'as a tool to serve the specialism - academic subject'.

It is an English for learning a subject or training for a job or occupation. It serves this purpose. This utilitarian use of English is a means that serves an end. It mostly starts at tertiary level. It has been going on for some time, Chamberlain. R. wrote : (1980:97) '...it still seems true that planned ESP programmes tend to begin at tertiary level'.

Though the 'Nucleus' series was mainly devised for use at tertiary level, it was adopted for use in the scientific stream in high secondary schools in Upper Egypt in 1977. This sounds an exception to the idea of tertiary level which is generally held. There have been similar situations in some parts of India and Malaysia.

ESP teaching/learning has been going on for some time. To mention a date, would be, the late fifties and the early sixties. Thus service English or as Robinson R. calls it 'English for Utilitarian Purposes' has been there for quite some time. This means that it has been servicing students' needs in their specialisms. The researcher sees no harm in adopting the term English for Service Purposes which serves as a blanket for all yet preserves the acronym already in use; namely ESP. It is fair to mention that Service English is not a new nor an empty term. It, in UK universities, means courses of English for Academic purposes given to students from other countries.

Swales (1977, 1983 :10) used Service English twice; first in 1977 in his survey article 'ESP in the Middle East'. He wrote:-

"I shall do this under three heads:

- (1) Motivation for Service English
- (2) Factors affecting the type of Service English programme
- (3) Factors affecting the quality of ESP in the Arab World."

Swales, in fact, repeated this in 1983 in 'A Review-Article- of ESP in the Arab World'. His using service English and ESP in these meant the same thing.

Stephen Andrew (1984:174) used 'Service English' in the title of his paper to the ESP Summer Institute held at Aston in Birmingham in 1983:

"The Effect of Arabicisation on the Role of Service English"
He also added "This paper will be considering the effect of potential Arabicisation on the role of Service English in a single institution, namely Khartoum Polytechnic,..... Firstly there has emerged a strong pressure for Service English outside educational contexts, particularly for purposes of commercial negotiation." my emphasis

He then summarised his role:

"Our task - English Language Unit members-; in the climate of confusion and uncertainty, has been to try to find some answers, and to identify a valid role for Service English, one that would survive Arabicisation."

In KBI where the English Department offers services to other departments, students learn English for they want to understand their subjects, to search or read more and to, on a limited scale, continue higher studies. Most of the students intend to work and so need ESP courses that will clearly respond to their needs. As we will see, results of researched needs will eventually form the right bases for ESP course design.

2.4 Historical Background

Though there is a reference for ESP by Strevens as starting in 1576 in the then-published material called 'English for Foreign Tourists', it was not the ESP we mean nowadays. Thus we can say that the evolution of ESP has been taking place during the last twenty five years. It was first introduced in the late fifties and early sixties as language courses for Science and Engineering in the UK, the USA and some oil producing countries. As practitioners were not satisfied with the literary courses taught for a multiplicity of purposes, they tried, therefore, to introduce new courses. This was gradually developed through the efforts of dedicated practitioners practising in the field of Service English or English for Service Purposes; as the researcher prefers to call it. Crofts N.J. (1981:147) mentions the life-time since ESP came into being:-

"It is now about twenty years since ESP textbooks began to appear in some numbers and about ten years since ESP began to gain general recognition".

Swales in 'Episodes in ESP' does not openly adopt the chronological development of ESP or, at least, claims not to do so. Yet it does, in fact shed some light on the whole period ESP has gone through from 1962 to 1981; a period of twenty fruitful years. Prolific ESP production has been taking place since then. This proliferation is due to many reasons. One of them is the oil boom in many countries like Libya, Iran, Iraq, Saudi Arabia, Oman and the United Arab Emirates. Another is the growth of national pride in such countries that wanted to instal and run their institutions and their industrial enterprises. The abrupt rise in the prices of oil and the surplus petrodollar incomes in the early seventies contributed to that. The development in computing or electronic data processing and

communications played a vital role in that direction. Even the need of the United Kingdom, in the early sixties, for manpower and foreign medical staff could be added to the factors ensuing that proliferation.

On the theoretical side, we mean articles and literature, as Swales (1983) suggested, we can start with J. Herbolich's article written in 1962 as a landmark. Much of what was done then depended on relevant vocabulary items and prominent structures recurrent in the discipline meant. Thornely's 'Scientific English Practice' 1964 and 1965, then R.A. Close's 'The English We Use for Science' belong to that period. Other efforts followed like Herbert's move which tried to take ESP from its routine mainly consisting of substitution tables and structural bases to the idea that it is general English that is being taught, but it is done in this manner to suit the expression of scientific notions in a variety of forms. This did not present a complete approach in itself. It did not point out what precedes and what follows. It was intuitively done.

Research did not really exist, in this field until Ewer and Lattore's 'A Course in Scientific English' which was published in 1969. They considered it the basic factor in determining ESP courses. The authors analysed texts of scientific English taken from a variety of sources and took the vocabulary items, structures, and other relevant data common in all sciences. The Collier-Macmillan series then followed. It dealt with the lexis and terms as most important. The use of dialogues and the interactional aspects served the purpose of extracting information. Its effect was very limited in the field of ESP.

The Eckersley and Kaufman, 1973, commercial and business courses incorporated elements of an ESP approach, but they were still traditional sorts of teaching materials.

Candlin et al's materials 1974, 1975, 1976, for nurses, doctors and doctor-patient interaction were usefully applied and soundly based on analyses in the relevant discourse in different contexts e.g. doctors in casualty. Bates and Dudley-Evans' edited 'Nucleus' series for general science started in 1972. It subsequently went on in many disciplines for many years. It adopted the notional approach; meanwhile the 'Focus' series, 1974 edited by Allen and Widdowson adopted the functional approach.

The 'Nucleus' General Science Teacher's Manual - expanded new edition - is an excellent realisation of the communicative language teaching and of putting it in practice too. The whole book - General Science - is included plus very effective directions for the teacher to handle each and every part of the twelve-unit book. A pronunciation key is even there along with a glossary and a few achievement tests. It is arranged in such a way that serves its purpose. The Manual includes '...advice on how to present and teach the material, with answers to the exercises and background scientific information'. It is, in fact, a comprehensive aid to the teaching of General Science.

Both series, 'Nucleus' and 'Focus' following an identical layout for each of them, did not contain 'authentic' texts and so served as introductory courses to the disciplines they served. The number of units, the sort of treatments, emphasis on diagrams or use of the visual elements and utilisation of the communication functions, both rhetorical and organisational, were different in each one of

the series.

The presence of many authorities in ESP in the Middle East gave rise to and accredited the status of ESP. Swales and his colleagues worked in Libya and the Sudan. Bates and Dudley-Evans served in Iran. Falvey served in Iraq. Wingard helped doctors in Egypt. Blackie and D. Adam-Smith worked in Kuwait. Herbolich and Munby did so too. Coffey and Jordan worked in Jordan. The King Abdul-Aziz University - KAAU - tripartite research groups of Candlin, Sinclair and Widdowson; each heading a separate group, helped lay sound bases for ESP courses in Saudi Arabia. They researched the needs of students and adapted text analysis of relevant disciplines. The presence of these groups ensured better bases for ESP than before. It also helped in achieving better results on the educational scale too. It helped nationals to adopt this line which is comparatively new to the Middle East area.

It was in 1976 that the first regional ESP conference was held in Alexandria, it marked international interest in ESP and promoted its status as well. The second regional conference was held later in 1977 in Iran. As a result ESP status was helped to flourish and given a boost. It was hoped, as Swales mentioned in 1983, that these conferences would take place every year.

On the theoretical side, many journals, and newsletters were there like the ESP Newsletter for the Middle and North Africa - ESPMENA, ESP in Alexandria Newsletter, Almanakh in Kuwait, ELI Monthly in Saudi Arabia. etc.

Widdowson's 'Teaching Language As Communication' published in 1978 paved the way to utilising language for communication in the

school curriculum in general and in ESP courses in particular. Though some scholars, like Wilkins, advocated the Notional-Functional Approach, they were criticised for replacing the structural patterns with an inventory of notions and functions whose strata and limits can never be completely realised by learners. They seemed limitless compared with the compendium of grammar rules. As a beginning they were, of course, meant for another category of learners. Nowadays it seems as if there is consensus on the use of communicative teaching. It can be clearly seen in ESP literature and the two ESP journals which are very helpful for those interested in the art. They tackle each and every aspect of ESP and always look forward to its betterment.

On parallel lines with the two forementioned ESP conferences held in the Middle East, British Universities have taken a deeper interest in the teaching of English which is also involved, in later periods, ESP. Several such institutions appointed lecturers, in a movement, which led to the birth of the Special English Language Materials for Overseas University Students - SELMOUS Group in 1971. This group became a dynamic centre of attraction and production in the field of ESP.

Initiated by comrades in ESP, the Summer Institute on ESP in the Arab World was held in 1983 at Aston in Birmingham. A part of its output was published in a volume having the title of 'English for Specific Purposes in the Arab World'. It was edited by Swales, J and Mustafa, H. Another fourth ESP conference was held in Bahrain in 1984. Relevant bodies took part. The researcher's Public Authority for Applied Education and Training was invited and represented.

Few encouraging recommendations were taken up. Thus voices became louder. Professionals wanted to discuss common issues. This culminated in the First National Symposium on Language Teaching held in Kuwait in 1985, sponsored by Kuwait University and supported by the highest ranking authority. Its recommendations seem very promising for language teaching in general and for ESP in particular.

2.5 The Needs to Know When Designing ESP Courses

Many factors affect an ESP course and its designer when setting out to do his task. These factors arise out of his job and all that is related to it.

We should start with the learner, his background and why he needs English at first. According to Munby (1978:2) 'ESP courses are those where the syllabus and materials are determined in all essentials by the prior analysis of the communication needs of the learner, rather than by non-learner-centred criteria, such as the teacher's or institution's preference for General English or for treating English as a part of General Education.'

We agree with Munby's first half of the definition but do not agree with the second. We will argue this point later. Getting to know about the learners, Fortune A. (1977:49) thinks contributes to the database that will enlighten the designer: 'the students are of different nationalities and have reached a reasonable intermediate standard of English...they are going to follow a university level course covering a range of disciplines.' He also adds: 'they (students) are grouped according to whether they are prospective undergraduates or postgraduates....'

The objectives of the learners, learner stereotype or why they intend to learn or train in English come next. Through knowing these, a course designer will be able, at least, to articulate these through his own perspective. The perspective differs with the type of ESP i.e. for Occupational, Academic, Scientific; Technological or Educational purposes. These can of course, be determined through many means. Then come the contents or materials through which the learners/students will achieve their proposed objectives. The sort of content needed is very much debated. Will it be direct subject-specific material? Will it be authentic? Or will it be teacher-made for the situation? These are immediately related to a methodology through which the teacher or trainer will impart the knowledge or training to the teachees or trainees in the proposed fields of ESP study or training.

The researcher firmly believes that mainly these, other than indirectly related elements like extrapolations from text analysis, classroom lectures and interaction in the learners' specialisation, have a direct bearing on needs analysis leading to proper ESP course design. Now we proceed to elaborate these factors.

2.5.1 The Learners. Any ESP course designer should take into account the learners - in our case KBI students. (see Chapter Three for more details). Their qualifications, interests, religions, nationalities, mother tongues and whether they learned the English Language or received any instruction in it before contribute a lot to determining the study needs of the learners. To know the learners and their needs like the purposive domain, the setting, the roles they would play, the instrumentality, the dialect and

the communicative event helps in designing ESP courses to **meet their requirements.**

With this information in mind the course designer can spell out the scope of the ESP course needed. In our case the learners are mostly Kuwaiti school leavers, Moslems, aged between 18-25; have some motivation for study at KBI and in most cases, intend to work in the fields they have been taught and trained in.

It has been found out that learning a subject in a foreign language is best achieved i.e. ESP course, for example, by starting after learners or students have had at least basic instruction, orientation or information about the intended target subject; in Arabic, in our case at KBI in Kuwait.¹ Several Departments of the KBI have the policy of teaching academic courses in English after giving basic instruction in the same subject in Arabic, the mother tongue. It has recently become a tradition of proven success. Some subject teachers usually lecture in English but do not have to teach the English Language.

It has also been mentioned that most ESP courses start at the tertiary level, as in KBI, which stresses the idea that learners' needs and their role in decision-taking are very important, for the course designer, in embarking on the nature and relevant issues of the course design that should be taken into account. It has been reported on the other hand, that 'The Nucleus' General Science Course, has been used in Egyptian High Secondary Schools in Upper Egypt since 1977. Other projects like that of the Malay schools and a few

1. M.Amer } formerly lecturers in Computer Science
U.Basioni } Department at KBI

Bangalore schools in India have also been reported. This pushes back the age limit of ESP utilisers from those generally above eighteen years of age to those a little below. It also, possibly, pushes ESP from tertiary level back to higher secondary school level. This on the whole is being done on a very limited scale. As Chamberlain R (1980:97) put it:

"It still seems true that planned ESP programmes tend to begin at tertiary level".

2.5.2 The Objectives. The objectives are concerned with the purpose for studying a foreign language. In some English courses, it is, an integrative purpose of settling in the country whose native language is the target language . In others it is an instrumental purpose that is a means to an end. The course designer has to bear this in mind so as to implement the means that lead to fulfilling the objectives aimed at. Some learners learn ESP for Academic Purposes, like those who want to study, for example, Engineering at an English University. They have to concentrate on listening, writing more than speaking, for example and sometimes reading. Others study for occupational purposes like medical secretaries, who have to concentrate on listening and speaking, less on reading for example, and some others for professional purposes like doctors. Yet some others learn it for vocational purposes like trainees in hotels or electricians etc. These can be grouped under Educational purposes. Some others study it for Scientific reasons or for Technology - EST.

Among the ESP courses provided by some institutions are pre-study and in-study courses for Academic purposes. Some take an ESP course as a refresher training course. (see 2.3 for the tree diagram relating to purposes). In some British Universities pre-session courses

have been a very successful traditional practice; in which learners are usually subject specialists but need to follow lectures and develop certain skills and relevant practices in English in reading.

Some Universities offer courses simultaneously, while learners are studying further in their specialisation. Such ESP courses help learners in achieving their objectives as doctors, scientists, technological engineers or technicians. Kennedy and Bolitho (1984:17-18) refer to the fact that 'Instrumental doesn't mean that a student studying 'Engineering' in an English medium University does not need English for integrative purposes of living in that community'. The ESP courses certainly enable learners to arrive at the **objectives** they are after.

Breen and Candlin (1980:96) have summarised it:

"...all learners regard themselves as learning a language for some special purpose".

For the purpose of this thesis and as will be shown in Chapter Three. The general objectives of studying at KBI have recently been summarised in Attia. M.H. (1985 :89-90)

- " (i) Preparing learners of both sexes to take overall practical and technical duties in the commercial, administrative and financial domains in both public and private sectors;
- (ii) Creating a good Kuwaiti citizen by inculcating cultural, spiritual, artistic, aesthetic and social aspects of Kuwaiti life;
- and (iii) qualifying graduates behaviourally, practically academically, and intellectually to undertake middle executive duties in Accounting, Management Insurance, Banking, Business Training and Computing and relevant job activities."

These are the general objectives. As for specific aims they add more to no.(iii) which shows that ESP at KBI is in demand to qualify graduates behaviourally, practically, academically and **intellectually**.EOP and all that is necessary to achieve purpose.

2.5.3 The Contents. An ESP course design demands answers to questions about the contents of the course or what Scott. H and Scott J (1984) described the "what-is-to-be-taught."

The researcher believes that materials should be prepared with the learners' characteristics taken into consideration. They should be based on suitable or relevant samples of language. They should also address the intellectual level of the learners, not be too simple or too complicated and represent the real units that occur in the original discipline. They should also cater for the specific discipline or target-texts the learners are aiming at. If not so, the materials will be as Mackay and Mountford (1978:10) put it:-

"Materials which have been prepared without the learner group's characteristics having been taken into consideration, based on unsuitable or irrelevant samples of language and units of description, will have low motivational value for the student..."

We always aim at materials or contents that suit learners or students. Materials that are relevant on the structural and lexical part to suit the communicative approach we will adopt. By so doing they will raise the motivation and morale of learners/students of that specific discipline.

These and other relevant issues about the content will be approached.

We believe that the contents of any ESP course should fulfil the demands of both learners and course designers in their being immediately related to the learners' target discipline or aim. The course designer should have taken into account the scope of his discourse and its relevance in various aspects to cater for the needs of the learners who form his target. We agree with Breen and Candlin (1980:89-112) who want the contents, in general terms, to have a-relevance, b-effectiveness, c-feasibility, d-efficiency, and e-balance of advantage. These characteristics are favourable and will be taken in the evaluating criteria for KBI materials in Chapter Three.

Some issues about the contents have received more emphasis than others. Authenticity is one of these characteristics of relevance to learners' needs, suitability, subject specificity progression and their having relevant forms to target discipline.

This characteristic refers to text or texts. Authentic texts were at some stages called realia which refers to any relevant materials taken, recorded or spoken on job sites. So it would be better to deal with both so as to make them clearer. According to Halliday and Hasan (1976:1):-

"The word text is used in Linguistics to refer any passage spoken or written of whatever length that does form a unified whole."

They then add a clearer view of the word 'text' illuminating the practical side:-

"A text is not a grammatical unit, like a clause or a sentence; and it is not defined by its size."

An even clearer view is added later:-

"A text is best regarded as a semantic unit; a unit not of form but of meaning....It does not consist of sentences; it is realised by or encoded in, sentences."

Another definition is given by Morrow K. (1977:13-15):-

"By text I mean a stretch of language, that is organised in some way to form a coherent whole...whether it is spoken or written."

Brown G and Yule G (1983:6) give a short and very compact definition of text as:

"A verbal record of a communicative act".

Having extrapolated the definition of a text as 'a unit of meaning of any length; a unified whole or entity of language spoken or written and realised in sentences', it is time to include the expression 'coherent' to the unit which is the text.

Now we proceed to the issue of 'authenticity' and whether we approve of it in designing ESP courses or not.

According to Morrow K (1977:13):-

"An authentic text is a stretch of real language produced by a real speaker or writer for a real audience and designed to convey a message of some sort....It represents one speaker/writer's communication to one particular audience at one given moment".

This definition adds the word 'authentic' meaning 'real' and 'directed to real audience' as opposed to hypothetical ones in specially contrived or written texts or courses. The definition of 'Discourse', the researcher believes should be included here, since any text if discipline-based forms, or usually forms, a discourse or else a part of it. Palmer J.D. (1981-75) gave one. He wrote:-

"We might define a discourse as a connected and self-contained body of language that has some identifiable instrumental or integrative purpose".

Then, in the same context Palmer again connects 'text' and 'discourse' with each other.

"Discourse is the communicative function of a text expressed in higher units than the sentence eg.in paragraph and episodes".

As is obvious in this definition 'texts' lead to discourse. But the issue of 'authenticity' still remains. In fact there have been a great many arguments concerning which to utilise when designing courses; the 'authentic' on the one hand or the 'simplified', 'adapted', 'invented', 'contrived', 'doctored' 'composed' or 'authenticated' texts on the other hand.

Those who are pro 'authentic' texts say that 'authentic texts' belong to primary sources and have the rhetorical features of the discourse learners or students aim at or will eventually engage in, which seems feasible. This takes us back to Robinson,P's 'Quintessential ESP' which the researcher likes but which he had to forsake for the many reasons of feasibility and practicability he mentioned then. As for her mentioning the learners wanting to exploit ESP because science or that specific discipline does not exist in their languages, she may be right. But this will not be on an enormous scale.

The literature with arguments relating to authenticity abounds in such matters. Some are pro 'authentic' materials. Beeching,K. (1983:17) wrote:-

"The appropriate model of language should be 'use' or 'authentic' language with a clearly defined context not the contrived pedagogical dialogues which are only to illustrate particular structures".

She prefers 'authentic' material because it :

"is an emotive one and particularly so in language teaching".

She even quotes French examples and mentions Abe et al amongst others as favouring 'authentic' materials. She also tackles the idea of 'authentication' adopted by Widdowson, H.G. who says (1976:19):-

"I think it is better to consider authenticity not as a quality residing in instances of language but as a quality which is bestowed upon them created by the response of the receiver".

Here, as Widdowson mentions, 'authenticity' is not in the text itself, it is bestowed upon it by the receiver, created by him as a response. The receiver, if not mature enough, will not be able to do that. The researcher believes that the specialist can bestow such a characteristic on the material he faces, though this could be argued further.

For Lee W.R. (1982:10) "authenticity refers to the use of English by native speakers of English, British, American, Canadian, Australian and so on - and it is a quality of teaching materials in the English used in speech or writing, in course books and during English Lessons."

Again he adds 'authentic language is commonly defined as language, which has not been spoken or written specially for language teaching. It may be used as teaching material but it has not been produced as such'. And again he goes on to say that

"authentic is that which has been used in successful communication".

Here he comes to a sort of **compromise** with two opposing opinions, that of Beeching who supports 'authenticity' and Widdowson who supports authentication. But his first opinion of 'authentic' material being produced by a native speaker is off point to the researcher, simply because science has no nationality and we cannot limit its scope to either natives or non-natives.

For Jones, K. and Mountford, A. (1978:152-153):-

"Authenticity is a strategic concern, the choice of relevant data and appropriate language. But authentic language is usually taken to refer to actual text material drawn from subject-textbooks".

This idea of authenticity sounds acceptable to the researcher as 'authentic' being taken from subject textbooks not only from spoken or written material by native speakers only. Phillips and Shettlesworth (1978) reprinted in Swales (1983) prefer 'Authentic Resource Materials - ARM'. They discuss ESP materials and decide on adopting graded 'authentic materials' taken from existing literature.

Hajjaj (1979) also insisted on the exploitation of 'graded authentic materials or texts' as the only convincing solution to the ESP materials dilemma; though his supervisor, Candlin, was not of the same view (1979:19-192). Mackay also encourages the exploitation of 'authentic' materials for reading.

Amongst those who insist on the exploitation of 'authentic texts' and those who reject it, the case should not stay unsolved.

Robinson, F. refers to Widdowson:

"He-Widdowson- suggests that the **materials** writer

should compose a text in basic science and foreground certain rhetorical features, thus giving the student practice with those elements of discourse in which the student might be expected to lack proficiency".

So Widdowson plainly refused 'authenticity' of texts and called for 'composed' or 'doctored' or 'contrived' texts for the good of the learner - student, to help him where he is in need.

Greenall (1981:25) refused the 'authenticity' principle. He wrote:-

"It was thought for a time that the use of 'authentic texts' would solve the problem. But the concept of 'authenticity' is now seen as an extremely complex one, and virtually unusable for practical teaching purposes. Compounded with this is the fact that many 'authentic texts' in the opinions of scientists themselves, are extremely poor examples of scientific writing".

So to him some materials are too complex; others are too poor and all are not practically useful and so are unusable. For Hutchinson and Waters (1983:113):-

"Texts in ESP materials are frequently inappropriate to the level of the learners' knowledge, either in the terms of language or content, in the texts containing an appropriate level of specialist knowledge, the language used to convey it is often too complex, conversely texts which are simpler linguistically tend to contain content so simple that the learner has no interest in it. The solution to these problems of complexity and/or simplicity - lies in selecting content which the learners (and) the teacher will be reasonably familiar with, but which has been given a treatment that makes it more interesting - a new angle".

So they are after 'doctored' texts. Swales (1981:81) is of nearly the same opinion: 'Now I do not want to imply that literature designed for ESP is necessarily more central or useful than material designed for other ends. Indeed the opposite may well be true, for the material here excluded typically represents primary sources,

whereas much of the ESP materials per se is secondary, idealised, filtered through the distorting levels of language teacher's perceptions, and de-authenticated for pedagogical purposes'.

It seems Swales is afraid of distortion, narrowing down, limitedness and of taking second-hand information. According to him 'authentic' materials may be more central for ESP. Yet they could well not be so. It is high time Swales celebrated his silver jubilee as an ESP teacher which simply means that he deals with ESP texts as a teacher not as a scientist or simply a writer. One can imagine all that includes on the practical and pedagogical levels. This, in our opinion, means that Swales should lay emphasis on relevance, communicative and pedagogical issues when discussing authenticity.

Crofts J.N. (1981:147-148) refused 'simplified' materials and called them elementary. He also refused 'authentic' texts, for, in his opinion, they suffer from, when taken for pedagogical purposes:

- (a) incompleteness;
- (b) disjointedness;
- (c) lack of examples;
- and (d) lack of practical examples.

A few pedagogical reasons could well be added to these like:-

- (a) grading in content;
- (b) grading in difficulty;
- (c) supplying a linguistic as well as meta-linguistic basis;
- and (d) supplying a communicative basis to these materials.

Even, in Morrow's view (1977:14) the availability of 'authenticity' of texts is not easy; if it were so, 'authenticity' itself is often adulterated: .

"If the situation changes in the slightest way, the language used will also change, and this fact ultimately makes the concept of 'authentic' in language teaching terms unattainable. For the language we present as 'authentic' is authentic to the very particular situation in which it was first used. By using it in a classroom for teaching purposes, we are destroying its authenticity".

Summarising his own view and making it easy for us Morrow wrote:-

"I have also looked at the idea of authentic in relation to texts, and decided that ultimately there can be no such thing as an 'authentic' text in language teaching".

For the researcher, texts have to have certain characteristics. They should be in line with the discourse of the discipline aimed at, that is to say, subject-specific. They have to have a suitable amount of information content, to suit the level of learners/students and their targets. They should take the same style of the original discipline, be graded and fulfil stylistic obligations. They also should be practically and pragmatically usable for teaching purposes; i.e. be in suitable progression doses which suit the social and/or pedagogical context. They have to be relevant in content and to situation and motivating as well. They in Morrow's words, have to answer all questions concerning: the what-content, the why-purpose and the how - be suitable for use according to certain methodology and be appropriate in so doing. It is only then that we can approve of using materials that are in harmony with these views, be they 'authentic' or of 'primary' sources, or 'unauthentic' or of 'second-hand' sources.

We are of the opinion that this can be carried out and achieved in two stages:-

- (i) Elementary and preparatory stage : Texts take or should take the form of 'simplified', 'devised',

'adapted', 'filtered', or 'doctored' or 'composed', materials that lead the learner up the steps of the ladder. They should have a minimum linguistic basis for general purposes, minimum lexical basis of the subject matter of the target discipline. They should also be communicatively as well as functionally based on the discipline they serve. These conditions or characteristics, as can be perceived, could be fulfilled through materials for our students at KBI, as previously described. Through such communicative as well as motivating materials, learners can be guided and will be able to reach the level of communicative competence aimed at, with steady steps based on a pre-arranged or suitably designed ESP course. Such a stage may be called 'transitional' to upper levels of competence. These materials will surely be as suitable to those students, described by Abdullah S. Tawfig, (1984: 195-196) from Iraq, as they are to our students at KBI. When they first come they face

- a - 'the shift from teacher-centred to self-centred approaches in teaching;
- b - the limited base of English materials they used to have...not suitable to cope with their study needs any more, and
- c - the very restricted attention span of any student'.

(ii) Advanced stage: This can be catered for through selected texts from 'primary' discourse of the disciplines aimed

at. These texts can also be supplemented with applications of exercises and suitable ways of exploiting them; such as linguistic, lexical, communicative and pragmatic exercises. Such exercises may include role-play, problem-solving, pair and group work, simulations and open-ended questions. Some of these exercises may not exist in discourses of specialist disciplines. If they do not, they should be added in order for the course designer and the students each to obtain optimal results out of the ESP course the materials were selected for; the disciplinary, local and international scale. Our aim should be the ability to communicate within the discipline...with'...native and non-native speakers'. We should even care for more 'communication among non-native speakers all over the world, both as individuals and as members of multinational bodies'. Though the quotes concern 'English as an International Language, they are, in our view, applicable to the very many ESP learners.

2.5.4 The Methodology As well as the contents, the methodology has to go hand in hand with the objectives the learners/students are learning ESP for. It has to correspond with the objectives in such a way as to satisfy the learners' needs, their discipline and their target jobs.

The essence of any communicative methodology depends on trying to engage learners/students in using language in naturally occurring situations. A word ceases to be its denotation when it is put to

use in a naturally produced sentence in an interaction. It points the user to the right direction. Using words in sentences in acts of naturally occurring situations means the interactants are trying to communicate something to each other. Putting the words in content and producing sentences as such refers to the fact that the learners/students or users of such words are engaged or engaging themselves in a communicative activity. Engaging in a communicative activity means that those engaged in it are indicating meanings beyond the meanings of words separately. This needs to be extended by using another knowledge. Those engaged in the communicative activity have other than the rules of the language itself. It is not only the propositional value of a word or sentence, that conveys the message. They are both the rules of Grammar and the rules of use according to Hymes (1979:15):-

"There are rules of use without which the rules of grammar would be useless".

Using words in such a manner is what differentiates communicative behaviour from lexical meanings of words encoding and decoding or competence (linguistic competence-Chomsky). The latter is very much different from the former which refers to communicative competence, which consists of both linguistic and social factors - Hymes. This communicative competence is simply the knowledge of rules and how to communicate what one wants altogether.

The word communicative has also been associated with 'functional' and/or 'Notional' syllabuses. The grammatical rules or linguistic system do not produce an appropriate utterance. There should be with them the social shared knowledge, and the intention or will to communicate. Hymes refers to four rules which he considers when

discussing 'communicative competence'. There are in fact four sectors.

- (a) Whether or not something is formally possible. This is equal to Chomsky's linguistic competence.
- (b) Whether or not something is feasible.
- (c) Whether or not something is appropriate to a certain context.
- (d) Whether or not something is in fact done.

So the pivot of any communicative approach is engaging language learners in use, not the linguistic system only. Littlewood suggests a gradual process of a- pre-communicative, and b- semi-communicative, which should lead to c- communicative language teaching.

Kennedy C.J. believes the Communicative Approach suits FSP courses purpose. Widdowson has for a long time been in favour of this approach and so have many others like Stern, H.H, Breen, Candlin, Mackay, Robinson, Swales, McDonough, Selinker and Hajjaj.

Hajjaj (1979) in Chapter Six, very much supported the communicative approach. He, after carrying out an analysis of four texts from four Physics textbooks used by the Faculty of Science of Kuwait University, selected authentic materials and graded them into a- elementary, b- intermediate, and c- advanced stages. He emphasised the functional activities pertaining to the discourse he analysed as well as its overall structure and organisation.

With many advocates of methods and lots of materials on the market, the course designer should work hard on his own course design and the needs relevant to his course utilisers, so as to choose the suitable methodology, which, as we can see, should be communicative.

Munby, J. (1978:1) wrote:-

"There has been a movement away from grammatical syllabuses, and then situational syllabuses, to what are variously described as notional, functional, or communicative syllabuses. A major factor has been the work of Trim and his colleagues, especially Wilkins in the Council of Europe Programme for a unit/credit system for adult language learning. Another line of development in this movement has been strongly influenced by the work in discourse analysis (written and oral) of Widdowson, Sinclair, Candlin, Trimble and their colleagues. However, the area of syllabus design which requires more systematic attention is the communication needs of the learner, especially the derivational relation of syllabus specification to such needs. In terms of designing courses in English for specific purposes (ESP) this seems to us to be of crucial importance".

Among those who chose the communicative approach are Johnson, Morrow, Byrne, Littlewood, Widdowson, Swales, Bates, and many others like Snow P, of the Crescent English Course, who advocates his course to be based on communicative methodology. His course, being mainly prepared for Arab pupils in the Gulf Region and in Kuwait, gives the KBI school leavers who were taught in that communicative methodology. So when students at KBI are taught in the same or similar manner, it may be of very much help to them. The aims of communicative methodology according to Littlewood, W (1981:85) :-

"... the learners' main purpose is to produce language which is acceptable (i.e. sufficiently accurate or appropriate)..."

Communicative activities take more than one form which range from supplying information gap, matching, games, role play, simulations to other diversified communicative activities, all of which serve the course and the ESP learner.

The teachers' role in a communicative approach should not be a traditional one, the source of information. It should be restated.

Manslow quoted by Sharma (1980:115) pointed out:-

"The humanistic trend in current educational psychology which has come to characterise learner-centred language teaching sets out four central objectives for the teacher in an individualised program:

- (i) help the student achieve his full potential;
- (ii) help the student discover his own identity;
- (iii) help the student become a self-directed learner who makes wise choices about his own learning;
- and (iv) help the student meet his basic psychological needs for security, belonging, dignity, love, respect and self-esteem".

Once a learner/student feels secure, he will surely take part in activities. He will try to express himself with confidence. He will try to communicate what he thinks of and what he deals in. Such sorts of activities in pair and group work, role-play and simulation which are communicative will certainly contribute to his success.

The teacher should be knowledgeable. He should act as a resourceful person if needed, an explorer of ideas ready to expedite by presenting or sharing ideas and experience with learners/students as well as those in the field such as employers and subject matter teachers. The teacher should manipulate the students' skills for their benefit and that of the course. The teacher should always be ready to cope with students' subject-matter for teachers are, arguably, not the knowers; they should be able to develop, accordingly, themselves and their courses according to recent and up-to-date information for teachers' benefit. After all it is the teacher/trainer who is responsible to his society, employers for preparing the output - KBI students-to efficiently shoulder their responsibilities after graduation, through having applied and properly utilised the suitable course materials through the suitable communicative methodology. 'Teachers' in Strevens' words 'should adapt chameleon

like' to achieve the best results.

2.6 Conclusion

The course design to be suggested is not that of the Cultural Council of Europe Unit-credit system, not the Survival English Course, not the General and Communication studies meant for British University students, though it may take or adapt whole parts from such courses. It should be as has been discussed till now, a course design reached at after performing:-

(i) Needs analysis of students of the certain specialism.

Questionnaires and interviews results go under this.

(see Chapter Four). These include views of teachers as well as employers besides those of students and graduates.

(ii) Analysis of some texts of the discourse of the discipline

aimed at. In our case two sample chapters from two textbooks selected by Computer Science teachers and

students from the sample population. (see Chapter Five)

In Bloor's (1984:17) words: "It is almost certainly likeable

to operate both target-centred and learner-centred needs"

analyses'. Through this analysis we broaden the scope

of needs to include teachers' view relating to subject

matter, linguistic side and pedagogy which learners/

students may not be fully aware of at this stage;

(iii) Analyses of classroom lectures or what goes on inside

the classroom of the specialism teacher-Computer Science-

So as to try to find a sort of cross-fertilisation of the

activities and strategies which usually take place
(see Chapter Six) with those of language teachers.

For number (i) or needs analysis above we find Munby's sociolinguistic Model as the most thorough for ESP learners which induces us to base our design on it. He classifies language skills into a taxonomy of 260 micro-skills in 54 groups for the purpose of selection. Such selection may be included in ESP courses.

We agree with Robinson (1980), Chambers (1980), Richterich and Chancerell (1980), Hawkey (1980), Mackay (1981), Kennedy (1984), McDonough (1984), and Bloor (1984) concerning Munby's taxonomy as being the most comprehensive. Yet we have to be selective as Bloor says.

Mackay and Bosquet (1981:7) are among the many ESP exponents who agree with this view. They even add other elements:-

"The community where the learners are operating or will eventually operate is one important source of information, whether the community is an ethnic or sociolinguistic group to which the learners belong, or an institution such as a university research center or a professional organisation or the work-force the learners will be required to join, it will have a more or less set of expectations for the learners as fellow workers and language users".

The quotation clearly refers to more than one party and asks for taking their views or set of expectations into account.

It may also be argued that the learning processes of the learners/ students should also be taken into account as they may affect the design of courses, eventually, the methods adopted for teaching-learning purposes. Robinson, F. (1980:27-28) quoted Richterich and Chancerell on the more-than-one party issue:-

"They - Richterich and Chancerell - suggest that the identification of learners' needs is undertaken by three separate bodies, the learner himself, the teaching establishment, and the user institution".

There are other factors that are likely to be involved in the designing of ESP courses such as financial resources, potentialities available and time allotted for such courses. They are of importance in decision taking relating to course design. There should be no rule-of-thumb in such matters. All previously mentioned factors plus context should be taken into account when setting about the task of course design.

The involvement of more than one party in deciding upon the needs of the learners has been emphasised by Crocker following. The learners' decision to learn a foreign language, once taken, will get the parties, previously mentioned to have been involved, on the move to carry out the steps required.

Crocker, T. (1984:134) rightly put it:-

"Thus at one end of the scale, an individual's decision to learn a foreign language privately would mean the individual carried all of these participants' roles. Whilst at the other end of the scale, institutional change involving external assistance would require a wide range of agencies and individuals (e.g. government departments, institutional management, external advisers, teachers and students) to undertake various aspects of the roles at different stages in the change process".

We should always bear in mind the learners/students' motivation by supplying appealing materials that interest them and by basing materials on their objectives knowing that their purpose is an instrumental one; to qualify for the Diploma, work mainly in medial jobs as specified in the objectives and all that is accrued. It has been recently promoted by certain financial and prestigious steps

by the State.

The matter of ESP course design should specify its aim as learning-centred, not only learner-centred as Munby viewed it, as Hutchinson and Waters emphasise. This has also been tackled by Widdowson H.G. as an on-going process during study and as a goal-oriented one when it aims at terminal behaviour on job sites. All of this, as we envisage it, will end in both the success of the learners, the course and the teacher. The learners, by then, would have been qualified to carry out their job responsibilities successfully while taking into consideration Widdowson's 'process-oriented' and 'goal-oriented' definitions of needs concurrently. The 'goal-oriented' Widdowson (1984:178) '...relates to terminal behaviour, the end of learning. On the other hand the expression can refer to what the learner needs to do to actually acquire the language'. 'Process-oriented' '...relates to transitional behaviour, the means of learning'. Through this we mean to let learners/students avail themselves of the means and processes which form language knowledge as a means of transitional learning: 'Process-oriented', should be carried out through teaching ESP target texts; that is teaching learners/students language behaviour.

Through this combination, we do not adopt one and reject the other. We should base ESP courses in such ways that allow learners/students to avail themselves of both simultaneously.

The principles implicit in our exposition of ESP, its definitions, its types and its historical background will contribute to our evaluation of ELP materials used in KBI in the next chapter. The issues of learners, objectives, contents and methodology with all that relates

to them will be used as criteria for evaluating ELP materials used in KBI in Chapter Three, too.

C H A P T E R T H R E E

THE BACKGROUND FOR ESP IN KUWAIT BUSINESS INSTITUTE

3.0 Inauguration of Kuwait Business Institute

The Advisory Committee set for planning the infrastructure of KBI in 1974 met the situation of multitudinous materials to choose from. Having at hand an abundance of published materials on the market, they decided on KLI to be used for first year students as a textbook.¹ They had in mind mainly the Commercial Secondary School leavers who would join the KBI. General Secondary School System leavers were also taken into consideration. It is worthwhile mentioning that the first group joined KBI in September 1975. The Committee left the rest to be decided on by the staff members of the English Department, according to the statute of the Institute.² They had envisaged the choice as most suitable for two main reasons at that time:-

(a) KLI was used, for remedial work, at Kuwait

University English Language Centre, that is

1. The Advisory Committee set up in 1974 by the Ministry of Education included among its members an English expert in Business Studies, the Director of Technical and Vocational Education and representatives of academic institutions, and private and public sectors.
2. Act 19; articles 1 & 2 of the Statute gave teachers the responsibility of teaching and examining their students. The Department Council was allowed to work on teaching, co-ordination, syllabuses and similar tasks within the framework of the Academic Affairs Committee of the KBI.

for remedial non-credit courses which were required prior to registration for any credited English course if students did not score above a certain level in a placement examination held for incoming students at the beginning of every term.

- (b) The book was new and based upon the decisions of the Cultural Council of Europe related to English Language teaching. It had the touches of recent developments. Examples of these developments may be seen in the short reading texts, listening materials, story line and transfer exercises. As well as these, there was a sporadic commercial bias on the lexical side.

The researcher will now proceed to examine developments in KBI for Men and its twin KBI for Women subsequent to this choice of materials. It is true that KLI helped as a start but was not the right kind of book to serve either the broad needs of juniors who needed reinforcement of the basic command of structures or seniors who needed subject-specific materials which KLI did not contain. Neither the students' needs nor the course specifications were met. Even the objectives laid down by the KBI committee themselves and which are not accepted by the researcher were not met.

3.1 Division of KBI Life Span

With these measures in mind the researcher has divided the life span of KBI, since its inauguration in 1975 till 1984-1985,

into three stages:-

- (a) 1975-1978 - the First Stage
- (b) 1978-1981 - the Second Stage
- (c) 1981-1984 - the Third Stage

3.1.1 The First Stage. The first stage started with the inauguration of KBI in 1975 and lasted till 1978. It marked the beginning which we may call an elementary stage. We call it this for two main reasons:-

- (a) There were no set or prescribed books for English Language teaching, those that would fulfil the announced objectives of the Institute, relating to teaching and purpose. Going through the General Objectives stated in the KBI Statute and Bylaws set down in 1974, the researcher could not detect any mention of set books or prescribed ones. Other points relating to needs but not how they could be fulfilled are there.

"Students should be taught through the most suitable materials for the purposes of working in medial jobs as assistant secretaries, assistant accountants, assistant operators and computer programmers, assistant Business executives, assistants in Banking, Insurance and Underwriting. New programmes could be added and the suitably-qualified could be recruited for their execution. Committees for the implementation of existing and new courses could be nominated from working staff

and others outside whenever need arises"³.

- (b) The English Department was not properly staffed since most teachers were transferred from secondary schools - General Education in Kuwait. Some of them had neither the qualifications nor the experience in teaching business courses for teaching at KBI as stipulated in the Statute. They did not have the proper qualifications for teaching ESP or Service English. Lack of suitable qualifications and suitable ESP training was in itself a departure from the Statute. Scarcity of suitably-qualified teachers may be added to the two previous ones.

3.1.1.1 Lack of Proper Needs Analysis. Such a period of transition with in-experienced staff of limited power was not likely to be a propitious one. It proved ineffective in providing students with the type of English language they really needed. Indeed neither from the teachers' point of view nor from the students' were researched needs taken into account when KLI was decided upon; those researched needs should have been ascertained from the beginning.

Kennedy (1980:119) agrees with Abbot that many institutions start ESP programmes without considering the needs of the learners concerned.

-
3. KBI Statute - KBI - 1975
KBI Statute - KBI - 1978

"It is quite right", as Abbots says, "that 'university and other bodies do call ESP programmes without considering student needs and that students often can succeed within the system by using mother-tongue handouts and notes".

W.R.Lee (1980:84)writing on syllabus construction says:-

"One cannot teach everything-here-but must choose, taking account of such considerations as the kind of learners, the learning situation, the length of the course and the likely situations of use".

Again Lee gives high priority to learners' needs and all that implies. He writes:-

"It is therefore necessary to know the learners know them as human beings as not simply as the victims of beneficiaries of Language - teaching syllabuses. The Learners always come first".(op.cit)

The researcher contends that learners always come first. He believes their role is essential but integrative with others. The others involved, as we have seen in Chapter Two, include the teacher and the employer who should have a somewhat equal weight in their decisions.

3.1.1.2 Kernel Lessons Intermediate. In practice KLI proved boring to General Secondary School leavers for it offered repetition of structures and proved somewhat over-demanding for the commercial school leavers. Teachers pointed out the irrelevance of the story line which is based on espionage story. Though it was still in use in 1976 and 1977, KLI did not meet the set objectives mentioned earlier in this Chapter and Chapter One as well; those objectives which were put forward to KBI students by the staff and the

Ministry of Education. While being experimented on, it was referred to as containing items contradictory to students' culture and traditions. Take, for example, part 3 unit 9, 5 unit 10, 1 unit 11, 3 unit 12, 5 and 6 unit 15, 2 unit 16, 3 unit 20 and part 1 unit 25. As Strevens (1980:79) put it:-

"Some of these - the variables governing TEFL textbooks and teachers - are restrictions upon which the teachers are actually permitted to do, for example in cultural matters. In some societies, for instance, the kind of boy-girl relationship commonly found in TEFL textbooks, illustrations of girls in short dresses, reference to Alcoholic drinks, mention of dogs as domestic pets, even relaxed relations between teachers and students if they are of different sexes - all these may be culturally unacceptable". (my emphasis)

These underlined issues, added to the irrelevance of the book and made it far from being the actually needed sort of book. It was not until late in 1977 that teachers and some students started grumbling that KLI did not help achieve the purpose or objectives, referred to in Chapter One. It was divided then into two parts, units 1-12 for the first term or English 101. Units 13-25 served the second term or English 102, then 151. It simply did not cohere with the objectives of the Institute. It was not, by any standard, subject-specific.

3.1.1.3 Dissatisfaction of Teachers and Students. Dissatisfaction was based on the fact that all structural items in KLI were the same as the Secondary School syllabus which made for a boring repetition. Only the story was new to them and it had nothing to do with Business. It was irrelevant, uninteresting and lacked the capacity to arouse motivation in the learners. In other words, it had no practical

application and did not deal with relevant materials in Accounting, Business Administration, Banking, Insurance and Computer Science as will be shown in Chapter Five. Even the employers whose needs the graduates were meant to meet were not satisfied with the English graduates had learnt at KBI. While training, graduates were criticised as not having been suitably qualified in English, by both private and public sector authorities.

3.1.1.4 Felt Need for ESP and Constraints. Due to such criticisms, the English Department held an extraordinary meeting and decided to design some materials that would cater for students' as well as employers' felt needs. That would certainly put into effect teachers' views and preconceptions. The job was painstakingly done in spite of the constraints that delayed the execution of such a task.

Such constraints were the lack of co-operation of other institutions, the lack of direct channels of communication with other people concerned and the slow process of government routine. On the part of the teachers, the lack of subject knowledge and task experience delayed the output of the process. The lack of a scientifically-based research of needs analysis together with injustice done to the full-timetabled teachers who were assigned part of the task and could not afford the time for it did not, naturally, provide the best output. Preconceptions and hunches were not the best bases to build on. A framework appropriate to context should have been provided as first priority. An inadequate output of mimeographed sheets was handed to students every fortnight or so.

3.1.1.5 Output of the First Stage The output referred to was practically tough for students to handle. Take, for example, the unit-extract-on Accounting. It consisted of a chunk which did not form a coherent whole. The students could not understand the discourse on the discipline simply because it was alien to them. On the whole the output failed to successfully represent the disciplines students were specialising in. The materials were supplemented with comprehension questions plus some linguistic exercises; no implementation of relevant tasks, communicative or pragmatic issues.

3.1.1.6 Supplementary Materials Supplementary materials were then suggested for the four courses- the two previously mentioned and the other two called English 201 for the third term, and English 202 for the fourth or final term.⁴ It was not until 1977 that the supplementary materials came into being. They were meant to give some orientation for students of all disciplines. They, on the other hand, eased the tense situation with light doses of comprehension passages that are Business oriented. They even served for progression purposes from general English in KLI to, abruptly, tough 'Business English'. They sometimes tried to bridge the gap between Business English and everyday use, displayed in the tasks

4. Recent Division of Courses. Below 100 = non-credit courses.

Above 100 - 149 1st term	First Year
Above 150 - 199 3rd term	
Above 200 - 249 3rd term	Second Year
Above 250 - 299 4th term	

graduates would have to perform in their careers and the practical side of life. The rationale for these was to implement English for Business whenever and wherever necessary and in the manner it is used in the Business market.

3.2 The Second Stage is marked by the introduction of new blood to the English Department, the sanctioning, addition and establishment of a new specialisation - Medical Secretaries - to KBI plus further development in English Language courses including the shift from KLI to KLP, effected by both staff and student complaints.

3.2.1 The Developing English Department. The English Department of KBI is characterised by its dynamism. The recruitment of new staff, the development of relevant research in both the UK and the USA and the introduction and development of new courses all indicate this. The merger of all English Departments in the other Institutes of Health Sciences, Applied Technology and Teacher Training was a step forward in the right direction of achieving co-operative efforts for promoting EFL and ESP teaching. It allowed teachers on various sites to move where they were needed. Indeed, they paved the way for co-operative efforts to utilise intramural resources. They also arranged for orientation lectures and seminars by co-operating with outstanding figures in both English and Education. In fact ESP took its first small step in the introduction of a new specialist course for Medical Secretaries as we shall see later.

3.2.2 Introduction of a Placement Examination The introduction of a placement examination was intended to sort out candidates into two categories, those who need remedial English and therefore will study

KLP, and those who do not and so will study English 101.

It aimed at sifting and thus helped in serving both sides.

As a result teachers had almost homogeneous students as far as standards were concerned and students were given remedial instruction according to their stage of development.

3.2.3 Introduction of Kernel Lessons Plus. The shift from KLI to KLP came into effect on the basis that it was more suitable for students than the former. It also dealt with Business oriented topics like 'A Programme for a Broadcasting Company'. Other topics of the same nature could well be found in KLP e.g. holiday making, space travel, strikes, advertising, letter-writing, work and money, inflation etc. It also addressed the correct standard of the students, being a Post-intermediate Course. On the linguistic level, it progressed from easy items like simple sentences, first type conditionals to different ones like complex sentences and third type conditionals and from common core lexis to almost specialist terminology and language use. The nature of the story was very much different from that of the detective story in KLI; it contained exchanges as between a manager-businessman - a secretary, a journalist which were relevant and motivating. However it was not suitable for KBI students because it did not meet their needs as it was not subject-specific.

3.2.4 Components of Each Unit. Each KLP unit contained:-

- (a) Texts and pictures dealing with the theme of each unit concluded with comprehension questions, question making, interviewing and giving answers.
- (b) Grammar exposition and linguistic exercises with

comments showing differences or contrast e.g. between tenses, nuances and how to learn and practice them.

- (c) Intensive listening activities, but these were not exploited by KBI teachers which meant an impoverishment of the students. Reasons given for this omission were lack of physical space plus technical difficulties and government routine. Yet through these listening activities one could bring spontaneous English speech, spoken naturally and at normal speed, into the classroom or the English Language Laboratory.
- (d) The short story excerpt with some new vocabulary and good exercises of filling in spaces, completion, rephrasing, multiple choice and comprehension questions.
- (e) The dialogue and/or conversation in which one part is missing and is to be produced by the students.
- (f) Summary and revision exercises in the last page of each eight-page unit. As O'Neill (1973) put it:-
"It explains small points, does special revision and gives homework".

KLP contains relevant everyday life activities. It develops the skill of reading for information. Had the tapes been used, they would have definitely helped develop the listening skill. Its dialogues develop both speaking and conversational activities and its homework assignments develop writing abilities of motivated students.

3.2.5 Shortcomings. Neither KLP nor its tapes have been fully utilised or exploited. Again technical difficulties, lack of physical space, lack of proper staffing of the English laboratory were deterrent factors in the progress of the English Department. Only structures or a few of them were drilled in the laboratory, which could be done in class as well. The pace of the lady speaker on the tape is faster than it should be, which made for another impediment in the way of students' understanding of the material on tapes.

The social cultural side of boy-girl friendship, the mention of alcoholic drinks and a few other examples were not acceptable to the community. The book was not subject-specified or ESP proper; it did not appeal to all students. On the pragmatic side, it did not contain much of what could or would probably be done by KBI graduates in their practical lives though the English Language was used in some variety-talking, arguing, and apologising for example-but on the whole the sample was not satisfactory. On the lexical side, it did not offer much of what can be availed of as specialist terminology, especially for KBI Computer Scientists.

It had not, of course, been written with KBI students in mind or had their needs researched.

3.2.6 Implementation. Kernel Lessons Plus was divided into two parts: Units 1 through 7 which served English 101 or the first term and units 8 through 15 which served English 151 or the second term.

Supplementary materials had to be prepared to compensate for the absence of commercial texts or ESP proper for course 151, relevant linguistic exercises, some lexical items and some pragmatic issues in a pedagogically acceptable way. The materials were mainly based on the previous pamphlets. The new materials, it was agreed, should include four simplified Business related topics plus four comprehension passages of the same nature. It was the teachers' view that 'doctored' Business related texts would be more appropriate than authentic ones from published texts for pedagogical reasons of simplification, progression, inclusion of cohesion devices and of functions of language and its use, all in relevant contexts. That should be performed in simpler language than that of authentic texts, which we have already discussed in Chapter Two. We can cite, as an example, 'Commerce and Trade' in the supplementary pamphlet of Course 151. Pages 3,4,5 and 6 consisted of texts with diagrams. Pages 7 and 8 consisted of exercises and questions asking for explanation, justification, exemplification, true and false and inference questions. Page 9 consisted of summary of the previous text and page 10 of answering comprehension questions based on page 9.

3.2.7 Teacher-Made Materials Courses. Courses 201 and 202 witnessed great changes in content and methodology. The English Departments had far-reaching plans for the different specialisations previously named. They decided to collaborate in preparing Business related texts by adapting them from original textbooks, introducing a variety of exercises and checking them amongst themselves to suit linguistic, lexical, communicative, pragmatic and pedagogical

aspirations. Each main pamphlet was supplemented by another containing merely comprehension passages which were chosen because they were subject-specific.

Exercises such as gap-filling with words, phrases, or derivatives, giving meanings, paraphrasing, completing missing parts, giving the gist ~~or~~ scanning for detail along with productive questions plus some other linguistic exercises were there spread over the units of each course. These were relevant, informative, graded and asked for a variety of activities. To make things easier for students, a glossary was also supplied. Such texts with these kinds of exercises, in the researcher's view, would form a transitional stage to authentic materials. They would also help develop all skills to enable the students to learn and study what the researcher called 'The Advanced Stage' in Chapter Two.

3.2.8 Constraints. What was implemented was really a part of what was agreed upon. Munby was approached, through the British Council, for advice on 201 and 202 Courses. He was kind enough to discuss the situation in detail and hand in some invaluable recommendations to the Institute. They were not implemented due to constraints of background, time, resources, culture and political considerations. But some of the recommendations surely helped in rechanneling some of the materials and activities into their right stream. A limited questionnaire was implemented to see students' needs. Visits to departments were paid, and discussions of course contents and objectives were carried out to help obtain a clearer view of what should be taught.

3.2.9 The researcher's view was that materials should be subject-specific, the methodology communicative and should utilise functions and be practicable. For pedagogical reasons the content should proceed from easy to difficult, to more difficult items which will help students achieve better standards than before. The researcher also pointed out the need for translation for graduates' future careers. These views of the researcher about the design, content and methodology were taken into consideration and should also be taken into consideration when embarking on designing new courses.

Various forms used in business activities were collected from companies, establishments, corporations, etc. having diversified activities. Then some selective samples were used for teaching purposes and for career-oriented activities and future-job responsibilities.

3.2.10 Details of 201 and 202 courses. Course 201 included five units relating to Business Administration, Accounting, Banking and Insurance and Computer Science specialisations. Each unit was supplemented by a variety of exercises ranging from gap-filling, meaning-giving, sentence embedding or rewriting in different ways so as to point out cohesive devices. There were also other exercises about derivatives, passivisation and sentence completion. These would help students while learning and develop their communicative competence in the future. As they did not exist or were insufficiently treated, their addition would help to enhance students' understanding and motivation. On the whole 201 pamphlet

was supplemented by another, mainly of comprehension passages to be skimmed or scanned, basically dealing with Business related topics.

In Courses 202 the English Department had the idea of catering for some service departments of Business Law, Economics, Office Training etc. If a student was put in a situation requiring him to describe the Institute, study or express his views he will be able to express himself in English. Students were taught structures to help them develop their communicative competence.

As Widdowson (1978:19-20) put it:-

"The teaching of usage does not appear to guarantee a knowledge of use. The teaching of use, however, does seem to guarantee the learning of usage since the latter is represented as a necessary part of the former. This being so, it would seem to be sensible to design language teaching courses with reference to use. This does not mean that exercises in particular aspects of usage cannot be introduced where necessary; but these would be auxiliary to the communicative purposes of the course as a whole and not introduced as an end in themselves".

To this Widdowson (op cit) added:-

"It was suggested that perhaps the best way of doing this was to associate the teaching of a foreign language with topics drawn from other subjects on the school curriculum. It might be added that even if there are administrative and other difficulties in the way adopting such an approach from the beginning, it should be possible to do so at a later stage of learning".

As a result and to achieve this purpose, units about 'Labour Law', 'Production Possibilities in Kuwait', 'The Kuwait Fund for Arab Economic Development', and 'The Central Bank of Kuwait' were included. Exercises were similar to those in 201 but easier and having work-relevance. However, tasks were mostly practical.

3.2.11 Some Immediate Responses. The overall design of the 201 Course, content of relevant material and partly-communicative, partly pragmatic methodology adopted by the English Department seemed satisfactory. The efforts exerted brought about fruition and field training supervisors outside KBI felt the results while supervising trainees. Other institutions did also. Kamal, G. (1980)⁵. "These trainees are better than the former trainees in English" said the Head of Accidents Department in Gulf Insurance Company.

The researcher believes the issues of course design should be negotiated further for many reasons. Subject specificity in ESP, may increase students' motivations. Usefulness in life, of ESP courses makes students work hard on them. Progression in materials also helps students in the learning process. Drawing students' satisfaction through needs analysis adds to the interest in ESP courses. Immediate-learning-needs and other future job needs if attended to will surely contribute to the efficiency of ESP courses. Use and usage should also be quite suitably attended to. Moving from pre-communicative to semi-communicative to completely communicative development in courses certainly serves the purpose of ESP courses.

It was because of such unaccomplished tasks that the Ministry of Education invited the Kuwait British Council representative to give support, especially in designing new courses. This resulted in the signing of a contract stipulating three things:-

- (a) The British Council should study the needs of Medical Secretaries and provide an ESP communicative course accordingly.

5. Personal Communication, Accidents Department Gulf Insurance Co. Kuwait

- (b) They should provide the KBI with another Business course embracing a few disciplines.
- (c) They should, with the approval of the English Department, recommend two books for 099 remedial course and 101 common core course.

All this has to be fulfilled within 24 months beginning from the date on which the contract is signed. Thus we see that an ESP course for Medical Secretaries is about to be realised.

3.3 The Third Stage

The Third Stage is characterised by its instability in the beginning due to change of head in the English Department. This left its practical, emotional and psychological impact. As Swales (1977:37) in Holden (1977) put it:- In The Middle East...

"The serious problem of lack of staff continuity.... changes of objectives based on impression and inclination....failure in maintaining contact with other institutions and organisations".

(contribute to discontinuity of ESP programmes and affect their progress).

In spite of this, work went on as usual. The contract between the Ministry on the one hand and the British Council on the other was signed. What ensued was that:-

- (a) The British Council representative started work by meeting - interviewing teachers, visiting classes for observation and gathering information about needs and analysing them.

- (b) The British Council invited the English Department to enlighten them on new materials and to exchange views for feedback.
- (c) The British Council encouraged a few staff members to read, seek references as well as start research in relevant areas such as ESP materials writing, testing, teacher-training etc.
- (d) They also offered three members bursaries, for short summer courses, which was very beneficial.
- (e) They caused exchange of views and opinions which enriched the teaching learning process.
- (f) They designed and produced a course for Medical Secretaries including authentic correspondence e.g. letter writing to their needs.
- (g) They started other courses as well. Through this they were trying to fulfil their obligations.

3.3.1 Partial Achievement of Objectives. Concerning the Ministry of Education to which KBI was affiliated, there was a five-pronged move:-

- (a) The despatch of Kuwaiti youth on scholarships to the UK and the USA to pursue advanced studies in Applied Linguistics, Education, EFL and ESP to shoulder responsibilities when they come back.
- (b) The sending of delegations from the Directorate of Technical and Vocational Education abroad to

see foreign projects and study other advances in the same field.

- (c) The issuing of invitations to people from similar institutions to seek advice and co-operation in the same field.
- (d) The initiation of self-study project through co-operation and collaboration with the Southern Association of Schools and Colleges in the USA. A seven-member team used to visit Kuwait twice a year for this purpose.
- (e) The commencement of co-operative activities with the British Council through their Kuwait branch for designing, producing and developing both EFL and ESP courses.

3.3.2 Proposed Cancellation of Kernel Lessons Plus.

KLP was highly appreciated at first when it replaced KLI for its Business bias in vocabulary and content. It treated complex structural items and had comparatively advanced pedagogic framework. But once again, as with KLI sentences making reference to bottles of wine or alcoholic drinks or girl-friends, bacon and one's wife being kissed by others were found unacceptable either from the cultural or religious point of view. Such references, were listed, handed in to people in key positions who, in turn, openly expressed their dissatisfaction with KLP. They, as an alternative, offered the English Department an opportunity to compare KLP with other recent textbooks that adopt the communicative approach and offer a common core course. The staff members stipulated content

relevance to the disciplines taught, communicative methodology based on natural progression and task-oriented materials as salient factors in the choice of any new book.

3.3.3 Cancellation of Course 202. The call for the cancellation of some English courses was so strong, for both administrative and political reasons that the English Department had to hold an extraordinary meeting to cancel one course and regrettably limit their perspective to three courses called 101,151 and 201; plus the courses for Medical Secretaries. Thus 202 was cancelled, in order to respond to the demands of a strange student body at that time, for lack of space in requirements and for a pragmatic reason of there being no need for English in carrying out job responsibilities.

3.3.4 The Changing Context of ELP. In Kuwait during the sixties and the early seventies, methods of teaching English have not proved as beneficial as expected or up to the standard aimed at. Many methods and approaches were put to use like the Grammar Translation and the Direct Method in General Education and the Structural Approach and the Modified Structural Approach, in both General Education and KBI.

Citizens claimed their sons and daughters could not give the right responses or were silenced if, for example, addressed by a native speaker. This really meant insufficient achievement through learning and teaching including materials, methodology, teachers and unsuccessful learners. The guardians complained that after more than 8 years of learning English at school, then at KBI, their

sons and daughters could not respond properly. The same persons could usually do well if they studied for only six months in the UK or the USA. This indicated that they were not bad learners at all but still it was cause for concern. Perhaps they need to learn so as to communicate in real life situations, and while communicating this helped them learn and then reinforce what has been learned.

In 1976 and 1977 researches carried out by the Ministry of Education, Kuwait, showed the need for communicative language teaching. The KBI, whose input is a part of the output of the previously mentioned Ministry, should simply adapt to this situation.

3.3.4.1 Advantages of the Changes of Context

- (a) The adoption of communicative language teaching was not without benefits. The Crescent English Course - in General Education, it has been reported, was published after carrying out a series of studies and researches in the region.
- (b) Learning English in a communicative way meant utilising the rhetorical functions and putting them into action. This is being partly utilised in KBI.
- (c) The Crescent English Course writers have done their best to supply appropriate materials, as a result of their researches. Similar efforts have been exerted at the KBI.
- (d) All four skills have had their justifiable shares in the Crescent English Course.

- (e) The Communicative Approach laid emphasis on communication by being used to serve communication purposes. This can be seen in the new materials for Medical Secretaries at KBI.
- (f) It allowed the utilisation of a variety of techniques like, pair and group work, role play simulation etc. Similarly such techniques have been utilised at the KBI.
- (g) It envisages enjoyment as a useful part of teaching and learning. It allows space for creativity. It is not mechanical drills, it is confluent language learning which serves teaching and helps enhance learning.

As the Authors, Butterfield, O'Neill, Snow have put it, 'Crescent' claimed that it is:-

"...a new and imaginative approach to the teaching of English as a foreign language which has been especially designed and prepared for pupils in the Arab World - (Currently for the Arab Gulf Area)..."

based upon the findings of extensive and considerable research carried out in the Arab World by a large team of experts. Crescent uses the most up-to-date techniques in language learning and teaching. The communicative nature of the Course reflects an important new trend in teaching methods to render the learning of a language an enjoyable and creative experience for the new generations.

3.3.4.2 Problems Created by the Change

- (a) Writing is a highly-complicated skill. It consequently

demands both talent and capability which may not exist in many people. It can not be easily taught. It requires much effort from both teachers and learners, according to Sawwan (1984). Since teachers laid more emphasis on the other skills, the writing skill status deteriorated with the new output from school leavers who join KBI. Moreover the students were not able to maintain the momentum in listening developed at school, because of the lack of materials at KBI with which to do so.

- (b) The communicative approach was welcomed by all teachers, students and pupils. Its being 'communicative' and 'imaginative' seemed to satisfy the authorities as well as the guardians. The authorities failed to comply with the requirements stipulated by the authors like sound-proof rooms, retraining of teachers etc. One can say nothing of this kind existed at KBI.
- (c) The English Laboratory is not given its due role. In class some students/pupils will hesitate to respond knowing that they are listened to by the teacher and the pupils, whereas they do respond in the laboratory if they know that only the teacher can hear their responses. In some cases in the KBI, students were given exercises which were not relevant to their specialisation.

- (d) The word communication has been mis-applied and its role diminished to a few expressions taught to pupils to show they are fluent when, in fact, they are not. Understanding, interaction and skill in responding to unpredictable situations has mostly been replaced with more learning by heart as Sawwan (1984) stated. The researcher can say that, it was pre-communicative' and 'semi-communicative' to use Littlewood's (1981) terms because it was controlled and nearly dominated by teachers.
- (e) Much emphasis has been put on techniques without being sure they are practicable. Songs form a good means of teaching rhyme, stress, intonation and pronunciation but one should remember pupils next door.
- (f) Actual communication involves authentic as opposed to textbook contrived language and is judged as successful or not on the basis of actual outcomes. Canale (1983:4).
Neither conditions for real communication nor appropriate outcomes are available. Pupils in Kuwaiti schools are usually taught certain stretches of words or expressions to use when asked certain questions- mimicry. They cannot respond properly due to lack of real interactional atmosphere and the need for English to be used in similar situations.

- (g) Most teachers have studied English Literature not linguistics, TEFL or TESOL and so have had no experience in teaching, which makes it difficult for them to be competent and master teaching techniques without being trained or prepared to perform successfully. KBI teachers and General Education teachers need to adapt to the new context.
- (h) Many teachers of English in the General Education Sector have neither gained a good command of the English Language nor have they acquired any real communication ability in English. Yet if they did not have 'communicative competence', how could they teach it?
- (i) Communication can be acquired, not taught, in social interactions. It takes place in socio-cultural contexts which are hardly seen in life, since our culture is vastly different from the English culture especially when it comes to religious aspects of life. This makes teachers resort to what is an artificial atmosphere in an attempt to get suitable classroom response.
- (j) Teachers were burdened with technical applications of sheets, cards, recorders, projectors, all of which reduce the time allotted for teaching and interaction.
- (k) The English Department at Kuwait University has established a maximum of four remedial English

courses to recent school-leavers. The main reason for this has been the low standard of those entrants, who had started learning English since the adoption of the Crescent English Course. An almost identical view to that has been formed by the English Department at KBI whose input comes from the same source.

Such problems, the researcher believes, could well be overcome, when proper steps to relevant issues of course design and its effectiveness are adopted as we will see in later Chapters of this thesis.

3.3.5 Rewriting of Course 201. Regarding 201, it remained almost as it was concerning topics, but differed in strategies. Take, for example, Unit 1 'Introduction to Computers' which consists of 5 short texts. It had a variety of exercises plus comprehension questions for skimming and scanning. It had also a suitable glossary. All the units were cohesive as texts but not coherent as discourse except the one on computers-though the exercises were not completely communication-based. The one on Banking used a different presentation.-that of the direct approach - dialogue form. Indeed staff members were trying to find an outlet to compensate students for the abolition of 202. Due to the differences in approach and methodology in the preparation of 201, a call for simplification was started. Teachers had to go through the materials of 201 again. The process was, unfortunately, not seriously taken, except in the Unit on computers. The writer showed his expertise through the choice of material, its

logical and scientific development and the pedagogic strategies employed for teaching-learning purposes. Students had to follow stretches of sentences to gather information, to reason things for themselves and to utilise language functions to help them in the current learning as a process and in the target as a product. As for the four skills, three out of four were dealt with; the fourth-listening to spontaneous English on tapes-was not. In general, teaching served both instant and future needs of the on spot learning and future performance.

3.3.6 Introduction of Materials for Medical Secretaries

The need for Medical Secretaries was strongly felt, in 1981, with the inauguration of five new ultramodern hospitals in Kuwait. Consultants, nurses and secretaries were recruited from abroad.⁶ Even the inauguration of some departments was deferred for lack of efficient personnel ranging from well-trained personal assistants to highly qualified doctors. Quality matters when dealing with human life.

Besides that medical staff are highly-paid, housed and usually have their demands expedited by the authorities concerned.

To relieve the budget, Medical Secretaries specialisation plus some other medicine related studies were introduced in both Kuwait University and the KBI. As for Materials, they were designed and prepared by the British Council, Kuwait.

6. Nurses and efficient secretaries, were recruited from the Philippines, Korea besides many other Arab Countries.

3.3.7 Pros and Cons of Medical Secretaries Materials. It was claimed, on production of the Materials for Medical Secretaries, that a needs analysis had been carried out for the aim of design and producing them. Yet we can say that they did enjoy certain characteristics as advantages.

- (a) They were partially based on research in both the items of language and the communicative process.
- (b) They were subject-specific and so relevant and motivating at the same time.
- (c) They dealt with the Medical register.
- (d) They were partially based on objectives set by future employers - the Ministry of Public Health.
- (e) They utilised language functions relevant to their topics.
- (f) They followed Medical procedures of treatment or case studies, filing and file-maintaining.
- (g) They were partly communicative and dealt with aspects of the communication process in the content.
- (h) They refer to career-related or job activities like jotting down information for writing letters or listening to and responding to oral or taped messages. They utilised the enabling skills to reach a sort of competence.

The materials are not without shortcomings though:-

- (a) The needs analysis process was not an appropriate one. It depended on preconceptions. No questionnaire was

administered to identify, gauge and collect information, the needs and interests of students who would study the materials.

- (b) The materials consisted of more units than necessary for a course or a single term. Only two thirds could be covered. The need for more materials ensued and the new lot meant no match between the materials and the time allotted for them.
- (c) The materials were not bound and were handed to students in separate lots. Mishandling and lack of motivation are natural results of such a practice. It was unhelpful on the psychological side, since a book has greater permanency and is more convenient as a tool of learning.
- (d) The materials were then divided into two lots forming the greater part of a course. This ensured a pledge for more materials since each lot was not enough for a whole course.
- (e) As a result of both b and d more material was needed and had to be prepared by staff members. This meant two different styles or approaches.
- (f) The utilisation of incomplete names or misspelt ones has been noticed e.g. Abdul for Abul-Rahman or Abdur-Rahman and Salaama for Salama. Such practices are not usually appreciated, if not resented.

- (g) The tapes, the researcher has ascertained, are of a bad quality so the listening skill activities are on the whole neglected or deferred for further notice. They should have been a factor for more success.
- (h) Besides being functionally based, the materials should have had graded structural bases; to supply students with linguistic and functional grounds to build on. Doing so would surely enhance the learning process. It has been argued that it is perfectly legitimate to base a syllabus on functions, as it is clear from the vast literature focussing on functional syllabus design. This may suit us in some circumstances. But what we referred to is to assist students. It is not one of the basic issues. As Wilkins (1976:1) put it :-

"As the learning of a language is most commonly identified with acquiring mastery of its grammatical system, it is not surprising that most courses have a grammatical or (structural) pedagogic organisation".

The researcher cannot detect such an organisation in the Medical Secretaries Materials. Neither had it been referred to in the teaching notes. This does not mean that the researcher is pro the structural syllabus. It means that he believes knowledge of rules and their proper and adequate utilisation will be very useful for students in developing their communicative competence.

3.3.8 Types of Materials that Should be. A general overview presupposes that the materials should be selected, adapted or doctored, simplified or produced so as to be used in ESP courses

for Business students in general and Computer Science courses in particular. These should have certain characteristics that lead to the fulfilment of purposes or objectives. They have been recently stated according to Attia, M. (1985:79) (see Chapter Two).

Though the researcher agrees with his colleague in respect of objectives of almost all specialisations, he finds they are lacking in their mentioning 'Computer Programming' only. They should include 'Computer operations' and 'Data entry' as well. Besides their meeting the objectives, the designs of courses should also be developed so as to be commensurate with and serve up-to-date objectives whenever required.

- (a) Materials should be adopted after following the basic steps in scientific research of facing a situation, feeling a problem, thinking of an outlet, trying a solution and, on finding it successful, applying it. This situation calls for needs analysis. For this purpose the researcher agrees with Chambers (1980:25) that needs-analysis is '.....a natural and healthy development in EFL'. 'This needs-analysis', as C.V. James, cited in Chambers, wrote:
- "...involves real and imaginary needs, demands, requirements, expectations and use'. What Chambers calls 'target situation analysis should be taken into consideration'. Chambers (Op cit:29) writes:

"This necessitates going into the target situations, collecting data in order to establish the communication that really occurs - its functions, forms and frequencies - then selecting from these on some pragmatic pedagogical basis. To this I - Chambers - agree with Munby when he says "The syllabus specification is directly derivable from the prior identification of the communication needs of that particular participant or participant stereotype..." but disagree when he goes on to say that "...it is possible to begin with the learner and work systematically forward to the syllabus specification that represents the target communicative competence". (Munby 1978:218). Chambers suggests that "...the student is not the appropriate main source for data".

Through needs-analysis as pointed out in Chapters One and Two - to come in Chapters Four, Five and Six, we can produce data which will provide an important basis on which to plan suitable courses that meet the researched needs of students or learners. The translation of the results into usable materials invites other sorts of knowledge about learning and teaching.

As we suggested earlier, learners are not the only party. Employers' views should be taken into account, besides those of the Academic institution concerned. Attia, M (1985:171) has come to a similar view: 'However

the learners' needs should not be viewed as the sole factor, but other factors have to be taken into account in the process of designing courses'. Indeed the researcher agrees with Hutchinson and Waters (1983: 113) 'that ESP courses which are forms of general EFL should be (Holiday, 1984:29) 'learning-centred' rather than 'learner-centred'. That means they should not concentrate on students needs rather than overall views of teachers, employers and situational needs. That means overlooking one side or party would be damaging in effect to all products. They should be, in as far as possible, the results of needs-analysis -the three-pronged fork of learner, employer and teacher or the Academic institution or at least a suitable compromise.

- (b) Since materials should be used as teaching materials for a certain group of learners; they should be directly related to the Discipline the learners are studying. After all, learners need to know their subject, deal with its various aspects in a language that suits objectives. Attia, M. (1985:26) comes to the conclusion that: 'Courses taught at KBI are unsuitable and do not fit the specific communicative requirements of a specific group of learners; that is KBI students". Concerning vocabulary as a part of an overall purpose the researcher finds that English materials should attempt to touch on 'common core' English at the beginning, 'semi-technical' vocabulary after that and 'subject-specific' terminology

in the end or a suitable comprehensible compromise of these in ESP. Discipline discourse and its rhetorical functions are of utmost importance in course design.

- (c) Materials should be motivating and progress through with necessities of having 'Englishes' general, social, technical and the English of a certain register which is to be used through and for carrying out job responsibilities during employment for a successful career.

- (d) Materials should not be as Swales (1981:11) wrote:
"ESP classes are offered combinations of duplicated sheets".

As stated before, they should exist as a result of needs analysis particular to the situation, deal with the type of English needed - see Chapter Two - be motivating and proceed from easy to difficult exercises and topics regarding the linguistic side. They should be in the form of a pamphlet or a book which is better than separate sheets as a tool of learning.

- (e) The length of texts and materials as a whole should be carefully considered for skill development purposes, elements of job needs, standard of learners. Attia, M (1985:169) quotes and agrees with Clark that:

"The first step in any language teaching project must be to design a syllabus that will reflect

the language needs and wishes of the learner concerned..."

They should consider the skills to be developed and the approaches to be adopted for practical aims or further study and no less importantly for time allotted for the course so as not to cause tension if some part is not covered or a skill is not properly practised for adequate utilisation.

- (f) Functions of language should be dealt with within the discipline considered. This should be done through the analysis of texts, studied by students, or potential ones, with the aim of similar, simpler, graded discourse for pedagogical purposes. This can be accompanied with results of observations of classroom teaching in the discipline which would result in betterment for all parties concerned:-learners, teachers and employers. It would serve the educative purpose and match expectations. This will certainly contribute to motivation and subject-specificity.

Litwack (1979:383-391) suggested a six-point needs-analysis process of job and needs-analysis for producing EFL Courses which the researcher finds very similar to the views adopted here.

- (g) Various tasks and linguistic exercises should be included in any materials that are meant for ESP courses to avoid monotony, increase motivation and make learners always ready and willing to take new

activities as individuals or groups to inculcate co-operation and make learning easier as a process. Formal learning is as important as informal.

Interactions that take place between teachers and students and among students themselves do contribute to learning a foreign language, even motivate it.

The learning process has, it should be emphasised, its effect as a process on the product. Every skill has to have its share in any ESP course but emphasis should vary now and then according to necessity.

It surely depends on the nature of the specific purpose.

A reading course should, for example, concentrate on reading, though writing must draw on reading too. It may be the case where the skills are often desirably integrated. Within and along with this, there should be a built-in revision system.

- (h) Co-operation between subject specialist/s and language teacher/s or course writer/s is a must for purposes of reciprocal orientation on discourse and content precision. Such a co-operation may lead to, almost, precision which all people involved in teaching-learning processes aim at. Skeham (1977:1980) referred to the success of such a process at Birmingham University in the UK.
- (i) While such co-operation between materials' writers and teachers' results in precision of content, adequate training for teachers should result in the success

of the course as well. So a design for a course should contain or refer to teaching and methods of handling the materials. This equips teachers with some information and self-confidence to carry out their jobs properly and adequately. Strevens (1981:527) wrote:

"Teacher training, then, can make a great contribution to the achievement of learning. But the training must be adequate in quantity and appropriate in nature".

The researcher is sure that teaching-learning communication is hindered significantly if a teacher cannot communicate properly or is not well-aware of what he is teaching. To get him to know it is a step towards ensuring good-quality teaching and successful performance resulting from training is another as well. This will eventually contribute to the success of materials produced for EIT courses and certain ESP courses. As Strevens wrote:-

"The quality of teaching affects the learning, to some extent at least. The important observation is that the poorer the teaching, the stronger the deficits upon the average learners' achievement, while the better the teaching, the greater the encouragement of average learners' achievement. And the only way to improve the average level of teaching, experience tells us, is through teacher-training". (Op Cit)

Materials cannot achieve objectives in the hands of a poor teacher. That is why we have to, at least, introduce, for example, the Computer Science materials to the teachers of English or potential teachers so as to help

achieve the purpose. Not much is usually known to an English Language teacher, except when he has a certain interest. So why not give him some orientation and place him on solid grounds!

- (j) Materials should be glossed, supplemented and accompanied by taped materials to make learning as natural, feasible and motivating as can be. Some variation of emphasis on each skill may be there to suit each situation and skill. They should be planned as all-embracing concerning language skills both on the receptive and productive sides; they should always suit the purpose.

The pragmatic approach, as Hilary and James Scott wrote (1984:216) is to be implemented in designing such materials for ESP courses:-

"The pragmatic approach to ESP course design recognises three dimensions in each - teaching - learning activity. These three are 1 - Learning progression; 2 - Problem-solving; 3 - Content focus".

- (k) Last but not least, the researcher finds that, piloted materials are best suited for teaching to avoid difficulties of completely unsuitable materials. Materials should be periodically evaluated, revised and valued as suitable, relevant, motivating, communicative, having linguistic as well as pragmatic specification plus being up-to-date to attain the objectives aimed at. As Richards (1984:17) explained:-

"There always should be a place for the development of courses; deleting the no more needed; adding the newly-developed'.

In the case of a Computing course in the sixties, for example, no mention of the chip could be there. Yet such a course should refer to the chip revolution in the late seventies. Revision, developing and updating, of course, should be there as a characteristic of successful courses. They should have orientations on testing which may go side by side with teaching. Thus we neither lose time ~~on~~ nor interest in the materials and yet perform differently but simultaneously for teaching and examination purposes (K.Morrow 1984).

3.4 Résumé of the Evaluation of ELT Materials used in KBI

ELT materials used in KBI in Kuwait included published books like KLI and KLP, for courses 101,102, specially tailored materials like ESP courses 201, 202 and Medical Secretaries MS - Materials 202 and 252.

In order to resume the value of the materials to KBI community of teachers and students, the researcher has prepared a table showing the criteria he takes into consideration for evaluation purposes and the courses he is evaluating so as to throw some light on such materials, and show how far they contribute to ESP and its right direction progress in KBI.

The evaluation criteria and the materials are presented in a table. The table is arranged in the following manner. The top

or the horizontal line refers to evaluation criteria followed by books and other materials. Two books KLI, KLP and four other English courses are included. Under the title there is a tripartite division showing: A = yes, B = No and C = to some extent. The first perpendicular line shows the evaluation criteria to be used and their subdivisions.

- (i) The first criterion used related to whether materials were chosen or adopted after researched needs process was carried out or not.

According to Robinson P (1980:11):-

"Implicit in the definition of FSP as purposeful learning and teaching is the idea that the purpose can be expressed and tested. Rather than studying for an open-ended period of time for a general examination, the student of ESP is usually studying in order to perform a role".

No researched needs process was carried out in the case of KLI, KLP and the Old English 201. The first two are a general sort of EMT material. They do not aim at preparing, for example, a computer science student to play his role of say, programmer, whereas the last three courses were prepared after a researched needs process was effected and so serve, to some extent, the needs of KBI students each in his respective field of specialisation.

- (ii) The second criterion related to whether the materials meet or met objectives of study a - during study,- and b - for career purposes.

Both KLI and KLP contain general EMT material; though

the latter may be said to have lexical commercial bias. They do not meet FSP objectives and we met that sort of criticism in Chapter One by some employers and again in Chapter Three by some training officers. The picture looks different with courses 202, MS 202 and MS 252. While 202 meets the objectives to some extent, both MS 202 and MS 252 meet the objectives simply because they were specially cut and tailored for KBI Medical Secretaryship female students.* The materials have been said to fulfil the learning and career objectives. This message was conveyed through the KBI Medical Secretaries trainer. Doctors in Kuwaiti hospitals expressed their *satisfaction* with KBI MS output.

The result was satisfactory because the materials met the scientific objectives and the language training met the practical and pragmatic career activities.

- (iii) The third criterion related to content or whether materials are a - subject specific; b - appropriate concerning socio-cultural content; c - relevant; and b - motivating. Quoting an example from Mc.Donough

* There is only one section of Medical Secretaries. It is at the KBI for women.

(1984:5) related to Wingard shows us the effect of appropriateness of teaching materials on learners.

'Wingard (1971), reporting from Zambia, was one of many practitioners who described his students' frustration at learning inappropriate English, and who (to remedy the situation) set out his own attempts to establish a more relevant programme in a university context.'

Giving general ELT materials for ESP students should be no more acceptable. It should be a practice of the past. Moreover, materials should reflect their relevance to the many faces of ESP, be motivating through being directly related to the **subject or its** ramifications as required by the programme. It is true that all GPE and ESP are teaching materials, but they differ very much in content and perspective. Each should be given in its appropriate context.

- (iv) The fourth criterion related methodology. It has been said by many ESP practitioners that there is a cross-fertilisation between ESP and communicative teaching. This is true according to Bloor (1984). Communicative methods take into consideration the microcosmic world of the ESP students - academic institute and their macrocosmic world of career in their future lives on job sites. Courses according

to Littlewood (1981:76-84) should aim at 'communicative uses of the foreign language-in our case ESP courses for KBI computer science students. The essence of any communicative approach is utilising language as a grammatical repertoire to communicate in socio-cultural occasions. Thus language becomes what it does, not what it is or the meanings of separate words put together. Communicative methodology should aim at '...relating student's..linguistic knowledge (past and present) to meaningful realisations of the language system in passages of immediate relevance to his professional interest or specialised field of study', according to Allen and Widdowson (1978:67).

KLI, KLP, 201 and 202 were dealt with as structural courses but Courses MS 202 and 252 were dealt with as communicative.

- (v) The fifth criterion relates suitability to time available for the course. Time as we all know plays an important role. It should be carefully taken into account.

In assigning time for teaching purposes a designer should take into account the amount of the material, length of time available and the learning attitudes of students/learners. In so doing he can achieve the desired results. In relating this criterion to

KBI materials we marked KLI, KLP and Course 201 as not suitable for the time available. Then we marked courses 202, MS 202 and MS 252 as suitable, but to some extent, concerning the time available for them. Time is important because if not suitable it may result in frustration and loss of motivation on the part of students.

- (vi) We divided the sixth criterion which relates an approach to skills development into three sections of a - integrative; b - as is necessary in the materials; and c - in the classroom. The skills intended, as we all know, are the receptive skills of listening and reading and the productive skills of speaking and writing. We have our reasons to object to this division but here we will take it as it is.

The development of skills according to objectives plays an important role in achieving the desired results through an educational or training process. Robinson P critising the English for Careers Series wrote (1980:46):-

"It is not clear how students are to 'improve' their 'overall ability to communicate' as no skills are referred to and there's no teacher's book".

Again writing about skills and the effect of English in Focus Series Robinson (1980:47) wrote:-

"The books certainly help with reading, but the writing practice is over-controlled and at times is closer to comprehension and grammar practice".

In our evaluation according to this criterion we marked KLI as adopting an integrative approach to skills development in (a) but we did not mark it as such in the classrooms due to not utilising the writing skills. KLP was marked in the same manner as KLI. As for 201 we marked it as b (no) since it was treated in that manner. The skills had hardly been developed through it due to many reasons of lack of time, inappropriate content and the structural approach it was taught in.

Relating to Course 202 (old) it was marked as not utilising the skills approach in the first two choices but utilising it only, to some extent, in the classroom. MS 202 and MS 252 materials utilised the skills as integrative and as necessary in the materials but it was not dealt with in the same manner in the classroom.

We end this chapter with the following résumé of the evaluation of ELP materials used in KBI. In Chapter Four we will be discussing the questionnaire as well as the interview as tools of research, their results and our elicited information besides the analysis that would surely help in giving us better views relating to course design.

C H A P T E R F O U R

TOOLS OF RESEARCH USED :

QUESTIONNAIRES AND THEIR RESULTS .

4.0 Introduction -----

The very general objectives of the questionnaire, to be used presently, are to gather information about the sample populations to be dealt with and to use this information as a documented systematic basis for the establishment of the needs of KBI students in general and KBI Computer Science students in particular. Identification of these needs from the information gathered from questionnaires administered to employers, KBI teachers and KBI graduates or under-graduates, may suggest modifications in or even changes of ELT materials used in KBI.

4.1 Nature and General Objectives of the Questionnaire and/or the Constructed Interview

The researcher has used a questionnaire in three forms for; Employers - E's, Teachers - T'S in KBI and Graduates - G'S. This questionnaire has been occasionally used as a form of constructed interview when need arose. In both the questionnaires and the interview forms, there have been slight modifications effected by the interviewee's job and the nature of his/her work. For example in the first section of E's questionnaire, question number 8 in the first section asks for the number of employees, whereas this same question does not exist in the other two forms.

Question number 29 section 4 in the T's and G's questionnaire asks for recommended Computer Science Textbooks, in different forms only. The teachers were asked 'What do you recommend...'...?' Whereas the G's were asked 'What texts are/were recommended...?' Question 30 was dealt with in the same manner in all the questionnaires, too.

4.1.1 The General Objectives of the Questionnaires are:-

- (a) Investigating the opinions of three different groups i.e. employers, teachers and graduates. Opinions are elicited in relation to the appropriateness of ELT objectives, skills to be utilised, tasks to be accomplished, texts to be read and/or studied and overall general standard needed in KBI graduates.
- (b) Presenting an evaluation of the satisfaction of these groups concerning what is currently offered by KBI and that, implicitly, may constitute part of a broad needs analysis.
- (c) Articulating the needs of the three groups and what they want in officials, students and in themselves in terms of competence in English in occupational and in academic contexts.
- (d) Eliciting information about the sample population to show how important their views are; each in their own position as E's, T'S and G's or would be graduates. This relates to the number of those needing to effect an opinion or a change.
- (e) Presenting this information in percentages so as to represent opinions given by E's, T's and G's. This

presentation will not eventually call for using statistics due to its clarity, being in tables that lucidly show them. The higher the percentages are, the more the opinion or factor is in demand and vice versa.

- (f) Gathering information which may be analysed for the purpose of specifying the needs articulated by E's, T's and G's.
- (g) Establishing data which will permit comparisons, contrasts of the results so as to show points of agreement, similarity or shift of emphasis within/ between any group of respondents and their expectations..
- (h) Establishing a basis in documented evidence for the evaluation of current ELT practice at KBI.
- (i) Gathering evidence through the results of the elicited information in order that it may be used as a basis for further suggestions relating to the broad needs analysis in the case of designing new ELT/ESP courses for KBI students in general and Computer Science students in particular.

4.1.2 The specific objectives of each section in the questionnaire are as follows:-

Section I aims to: (a) Collect demographic information which is an essential basis for systematic presentation of opinions being investigated.

Section II aims to : (a) Establish the need for English Language

as a start and going through to the utilisation of both receptive and productive skills.

(b) Establish a documented basis for the needs analysis to include skills both receptive and productive. Skills in a broader sense than is usually understood. We mean also the sophisticated '...taxonomy (which) consists of some two hundred and sixty skills subcategorised into fifty four groups', According to Munby J. (1978:117), out of which we hope to select appropriate ones to our purpose. The categories meant for our purpose may start from skill 19 through to the end of the taxonomy. It will then have to be subdivided for pedagogical purposes. Both extremes of too easy and extremely difficult categories will be left out according to needs spelled out by E's, T'S and G's.

Section III aims to create a documented basis for the evaluation and establishment of the view relating the inclusion of some of the enabling skills referred to in the objectives of the previous section and the present one in any ELT/ESP course design in the future.

Section IV aims to: (a) Establish a documented basis for evaluating KBI output.

(b) Investigate the need for foreign languages and here we mean English.

- (c) Investigate the need for English in training.
- (d) Elicit information about Computer Science textbooks in use; to use Chapters from them in text analysis process in Chapter Five.
- (d) Elicit opinions about the usefulness of English for KBI Computer scientists' careers.

Section V aims to: (a) Establish a systematic criterion for the choice of an orientation.

- (b) Elicit information about the suitable shift of interest in the skills.
- (c) Elicit suggestions and maybe forgotten points of interest.

4.2 The Usefulness of a Questionnaire as a Research Tool

The usefulness of the questionnaire as a research tool need hardly be argued. For the purpose of this thesis the researcher has designed three questionnaires. One for a sample of the population who employ KBI students or would-be graduates and those about to employ them. Another is for the sample of people engaged in language and disciplinary studies at KBI who set down their experience of the language and disciplinary methods employed, using just those terms of preference which the researcher has singled out. The third is for a sample of the graduates' community. Those who graduated and those who are about to.

Unfortunately those who receive the questionnaire are not always enthusiastic about their contribution, for such requests proliferate and business people have other ways of spending their

time. One glance will tell them, furthermore, that this one is going to take a great deal of time and thought. It must be seen at once that the enterprise is worth their effort. For the researcher, information is given in detail on the strengths and weaknesses of language teaching on the ESP course in English. People giving the information will be those most concerned since they will either be actively engaged in the course or else employing those who have received their training from it.

Thus the researcher is able to base his planning for FSP course design and or improvements on significant opinions, whose numbers indicate a general trend. He will be able to generalise building upon the sample of population he selected.

As Van Dalen (1962:11) put it:-

"When examining all the instances of a class under consideration is not practical, one does the next thing: arrive at a generalisation by observing an adequate and representative sample from the entire class'.

On the other hand the original expression of one contributor may indicate a line of thought which is quite new to the researcher , especially since space is always given for the expression of just such a comment and participants are urged to make it. The researcher will then spell out the results of the questionnaires in order to lay the appropriate bases for the aim of designing ESP courses for the population whose samples will be taken into consideration.

4.3 Why Are Employers', Teachers', and Graduates' Views Taken Into Consideration ?

As for managers directors they obviously want to make themselves feel that their views, as employers, are paramount; they are considered so by the researcher. Employers do not always endorse new teaching materials and methods, however distinguished the language teaching source from which such materials and methods emanate. They are usually anxious to deal in practicalities and that is no bad thing as long as it does not intimidate language teachers and make them unwilling to try out new ventures. Employer samples were randomly selected.

4.3.1 The Constructed Interview. Since the questionnaire, therefore, is a demanding task, some of the recent graduates involved and some of the students who are about to graduate may feel it to be beyond their reach to respond without any help. Their reactions are valuable all the same, so the researcher has to employ a different method. and this is where the constructed interview comes in as another tool of research. As Van Dalen (1962:128) rightly put it:-

"No single method of obtaining data to test a hypothesis is perfect. Each one has certain inadequacies which leave the door open for the possibility of rival hypotheses explaining the findings. If a questionnaire is employed, one may bolster the self-reporting weak spot in the method by adding supplementary methods that have different methodological weaknesses, such as observing.....and interviewing".

The researcher agrees with Van Dalen as to what he wrote, for as he mentioned, in the same Chapter from which the previous quotation was taken (1962:127):-

"Each tool is appropriate for acquiring particular data and sometimes several instruments must be employed to obtain the information required to solve a problem".

The answers the researcher wants to elicit will be based on exactly the same concerns as those found in the questionnaire, indeed the researcher may keep an open copy of this at hand whilst conducting the interview, but the questions will be framed in a different fashion perhaps with examples or suggestions to make the response easier. A small group is clearly a better proposition than a large one and given the fact that a number of students large enough to warrant a significant conclusion must be interviewed, the enterprise is a lengthy one demanding tact and flexibility of approach.

Robinson has mentioned Richterich and Chancerel. She referred to their use of tools of research (1980:28).

"The final part of Richterich and Chancerel's study is a comprehensive survey of all different sources of information for a needs analysis. These range from surveys, questionnaires and interviews through language and intelligence tests to attitude scales to job and content analyses".

Though constructed interviews, which the researcher is going to replace questionnaires for some graduates with, are time-consuming, they have many advantages.

- (i) The answers are clearer- speech allows and enables people to make themselves understood because they can elaborate if asked to do so.
- (ii) It is plain to see when an interviewee is in difficulty, putting this to rights.
- (iii) Where someone has misunderstood the question can be established.
- (iv) When on examination, an interviewee would be leaving a blank on the questionnaire, a constructed interview

ensures the rarity of such blanks.

In fact such views are nearly identical with those of Mackay (1981:136):-

"Previous experience had shown the inadequacy of information-gathering instruments that were left for the students to complete; they were returned with the answers to some questions left blank, while misunderstanding of questions was obvious from conflicting answers, and anomalous answers were difficult or impossible to follow up". my emphasis

Since Mackay had faced this situation and the ensuing difficulties, he resorted to constructed interviews:-

".....It was decided that the questionnaire should be conducted as a structured interview.....In this way it was expected that the deficiencies in the type of questionnaire mentioned above could be overcome". (Op.Cit)

These quotations simply support the researcher's point of view in his resorting to both tools of research.

Jo McDonough (1984:42) wrote about research tools in her book 'ESP in Perspective'. Her opinion is that which is shared by many others who use questionnaires, interviews or both in combination:

"The principal tools for analysis are the questionnaire and the interview. Course designers in various parts of the world used these tools in different ways, and with varying degrees of detail and complexity. They have also been used in combination".

4.3.2 Employers' Questionnaire The researcher now proceeds to the employers' questionnaire. Ten corporate bodies with branches using computers have answered the questionnaire or interview. Each one of them has branches, uses computers on the premises, employs or

-
1. Body represents the concerted opinion of a group of individuals. The number ranges from 4 to 14 all of whom are involved in the sample taken.

will potentially employ KBI graduates and deals in business or with business concerns either directly or indirectly. They are either properties of the private sector like W.J.Towell, Kuwait Finance Centre - KFC - and AlTukheim International Exchange Company - TIEC or belong to the public sector like The Ministry of Communications and The Ministry of Education or are a combination of both like The Gulf Bank - GB - and the Burgan Bank - BB -. Added to these are The University of Kuwait, Kuwait Airways Corporation - Accounting Department and The Public Authority for Applied Education and Training - PAAET. In short they really represent employers and potential employers of the Kuwaiti workforce.

The information elicited from the questionnaires was dealt with by the researcher, manually. With a great deal of enthusiasm assisted sometimes by a calculator the job was painstakingly done. Some responses to questions were put in tables "In fact most responses were". The rest were not put in tables due to their not being suitable for representation in tables. For "question" we are going to use "q" and for "number" "no" henceforth.

4.3.2.1 Section I - personal - includes ten questions establishing name, age, nationality and responsibilities. See Employers' questionnaire in Appendix 2.A. This is a very important part since it keeps the researcher constantly in mind of the widening scope of the language enterprise he and his colleagues are engaged in. Although the E's cannot and should not design courses, they should obviously play the main part in making suggestions on the content of courses for many reasons, most important among them is the

weight of such opinions.

- (i) They have their own experience and expertise in service and in "business" and that term covers a variety of businesses.
- (ii) They employ and/or will employ KBI graduates.
- (iii) They allow KBI students to train on their premises.
- (iv) Some of them have their own training programmes.

As Swales (1984:11) quoting Davies mentions:-

"Secondly, there has been a growth in organisation-based language training, particularly in the context of large construction and operation projects".

- (v) Some of them serve on the Board managing the Authority for Applied Education and Training.

This means they are already involved in Applied Education in Kuwait. They are able to cope with the exact language used for questions in modern linguistics - take for example question 21b, on the idioms and acronyms related to a special line of business. Out of their experience they are likely to have insights which may not be available to some academics, hence the personal information which they give.

Those who received questionnaires and/or were interviewed were approached on a personal basis; they themselves showed zeal and willingness to spell out their views. They also showed richness on the demographic side. They comprise 7 males and 3 females. As for nationality, 6 were Kuwaitis, 3 were Jordanians and the last was Lebanese. This shows that the majority or the percentage of 60% are Kuwaitis. This contributes to the homogeneity of opinions. Their ages ranged between 35-42 years. This also refers to the

experience gained being above 15 years as a mean for all E's. Concerning qualifications, they at least had B.A's or B.Com.'s in business or business related specialisations and were employed by their own institutions. Eight out of ten had graduate qualifications. Yet they in turn would play leading roles in recruitment of new employees. Their responsibilities ranged from being heads of departments, key-position occupiers to decision makers each in his own institution. Their views, as is clear from the demographic information, especially the number of people they supervise, will certainly be of importance when it comes to making changes effective as the majority are Kuwaitis.

4.3.2.2 Section II . English Language Skills and Levels of Proficiency Required by Officials - Graduates.

This section comprises 7 questions, numbers 11-17, beginning with an estimate of the need for English and the level required in understanding, speaking, reading and writing it. Then come questions 16 and 17 which are concerned with the relative importance of the receptive and the productive skills, since such an emphasis influences the course designer. The section as a whole clearly indicates the skills to be included and the degree of attainment which may be required in them -the matters that are surely helpful to course designers.

As for the first question - referring to the need for English - its answer was 100% positive but varied concerning particulars. While 60% said they used it often, the Other 40% said that they used it occasionally. This shows that English is often needed and utilised by the majority.

Question 11

Section II

Table 2

Are Your Employers Required to Use English?

Yes	Response		No	Total	
	Often	Sometimes		10	100%
10	6	4	-	10	100%

Establishing this as a fact, we proceed to the other responses concerning the level of proficiency required in the four skills.

See the following table:-

Section II : Table 3 of answers showing necessity and order of proficiency in the 4 skills

Question	A = Excellent		B = Very Good		C = Satisfactory		Total	
	No	%	No	%	No	%	No	%
12 How should the Official's -G's of understanding spoken English be?	1	10	6	60	3	30	10	100
13 How should his speaking skill be?	1	10	7	70	2	20	10	100
14 How should the reading skill be?	1	10	6	60	3	30	10	100
15 How should the writing skill be?	1	10	6	60	3	30	10	100

As is clear from the table, employers prefer the very good standard in all of the four skills. To make things clearer the 'A' which is 'Excellent' is between 85 and 100. The 'Very Good' which is 'B' is between 70 and 85 and the 'C' which is 'Satisfactory' is usually between 60 and 75. The majority of them do not go to both extremes. The analysis shows that they have a tendency to accept what is satisfactory but prefer the very good. In question 17 they resort to difference in opinions and most of them - 80% - prefer to re-order the skills as speaking, writing, then listening and reading.

Table 4

	Yes		No		Total	
	No	%	No	%	No	%
Q.16 Should Proficiency in Receptive Skills and Productive Skills be equal?	2	20	8	80	10	100

Q.17 If 'no' How would you rank the Skills?

1	Speaking	} 8 = 80%
2	Writing	
3	Listening	
4	Reading	

4.3.2.3 Tasks to be Accomplished in English - Section III.

Continuing the subject of skills, also the enabling skills and the degree of attainment in them and the fact that the KBI graduate will be required to act and think not only as a student but also as a member of the workforce - Questions 18-21 deal with the 'Englises' he will need to use: of a general nature in getting and giving information, of a social and technical nature with colleagues and clients and in dealing with meetings, correspondence and business transactions. As Quirk (1962:21) rightly put it:-

"The uses to which English is put are as various as the peoples and societies that use it".

He then elaborates on the point in "stylistics." Regarding English, the needs and practises in different situations:-

"Each of us works not just with one English but with many Englishes, and the wider the range of our life and the more contacts we have, the wider and suppler must be our command over a range of English styles, each of which we know how to use consistently". (Op.Cit)

Then come the use of charts, figures, tables, diagrams - non-linear texts-which are used to serve either as illustrations of ideas, texts and topics or processes or form an integrative part of a topic or text and eventually discourse. These along with technical terms play an important part in business transactions and it is here that question 21 fits; it seeks to establish the ease with which technical terms are understood and used. Munby J. (1978:126-131) (where the Chapter 7 on language skills selection exists) comprehensively presents the skills including the four skills besides the enabling skills in fifty four main groups divided into 260. To suit our purpose we lay emphasis on group 19 to 54. We left out 1-19 because our students had acquired them in previous stages of learning. The following table shows the responses obtained concerning the tasks to be accomplished:-

Responses to Qs 18-21 of Section III of the Employers' questionnaire Table 5

No	Description	Percentage of Always		Responses often		Sometimes		Never		Total	
		No	%	No	%	No	%	No	%	No	%
18	The Official is to use his understanding skills with his boss his colleague " subordinate " client	1 1 2 -	10 10 20 -	3 7 2 7	30 70 20 70	6 2 3 3	60 20 30 30	- - 3 -	- - 30 -	10 10 10 10	100 100 100 100
19	The official is to use his spoken English receiving/giving information asking / " explanation " holding meetings	1 1 3 2	10 10 30 20	7 6 7 6	70 60 70 60	2 3 - 2	20 30 - 20	- - - -	- - - -	10 10 10 10	100 100 100 100
20	The official is to read English when taking instructions/circulars issuing instructions/holding meetings handling correspondence/mail directing transactions handling orders	2 1 3 1 1	20 10 30 10 10	7 7 5 5 5	70 70 50 50 50	1 2 2 2 2	10 20 20 20 20	- - - 2 -	- - - 20 -	10 10 10 10 10	100 100 100 100 100
21	The official is to be familiar with -certain terms necessary for his job idioms/acronyms related to his job figures, tables, charts, diagrams proper channelling of certain transactions	8 8 8 8	80 80 80 80	2 2 2 2	20 20 20 20	- - - -	- - - -	- - - -	- - - -	10 10 10 10	100 100 100 100

4.3.2.4 Section IV or In-Service Training: Since the researcher's eventual and practical/professional aim is to initiate a certain amount of change specially towards ESP courses, questions 22 and 23 are probing questions on the training in English as it is now up till A.D. 1984-1985 at KBI, on the need for English and whether the courses there meet first the general objectives of KBI and eventually the requirements of employer satisfaction as opposed to those partly in question 21 in the previous part. Texts in a language 'other than Arabic' are envisaged; this strictly speaking, means English and questions then follow as to how much of it is to be mastered, within the four skills, before an office-worker could cope with contemporary techniques, computer tools and devices, also the new language of management sciences.

The results of this section IV of the questionnaire go in the direction of change. They even emphasise the need for change; 80% or the majority see the output of the existing courses as in need of further training to cope with job responsibilities. They want change since the aforementioned courses are not sufficient e.g. question 23. They ask for more training and re-ordering of the utilisation of skills according to the importance they envisage as speaking, writing, listening and reading in the answers to questions 24 and 25.

The results not only refer to the need for more training, re-organisation of skills but they also ask for knowledge of a foreign language - English - and they consider that knowledge and access to it as an advantage; 90% of the respondents to question 29 support this view. If 80% of the responses to q.31 see

English as 'Very Useful' for career purposes, then it must be taken into due consideration by course designers. They should translate this into relevant courses or teaching materials. The following Table 6 shows the responses to most questions of Section IV.

Table 6

Q. No.	Yes		No		In Some Cases		Total	
	No	%	No	%	No	%	No	%
22	1	10	8	80	1	10	10	100
23	8	80	1	10	1	10	10	100
24	3	30	7	70	-	-	10	100
26	8	80	2	20	-	-	10	100
27	8	80	2	20	-	-	10	100
29	9	90	1	10	-	-	10	100

Q. No.

22 What do you think of your official's training at KBI; has it been sufficient to meet job demands?

23 Does/did he need further training in English?

24. If yes, what language skills and activities does he need to be trained in?

26 Does he need regular training to cope with up-to-date techniques?

27 Did he need in-service training before he started his job?

29 Do you think your officials could gain anything from knowing a foreign language?

4.3.2.5 Section V : Overall Standard of Efficiency of KBI Graduates

The four questions in this section; 31-34 are of an open-ended character and ask for the employer's favoured emphasis in the skills he would most value in a KBI graduate in his employment. Particular suggestions concerning such skills are to be made. The final question is an invitation to contribute a last word on methods of instruction. There may be something which had not been mentioned. The final question is of the utmost importance in determining the kind of teaching or training at KBI and devising materials to be used in it. An opinion, strongly supported throughout various businesses will receive attention, so will the accepted lone contribution where it is applicable as well as novel.

Responses of Q.s. 31 & 32 of Section IV of the E's questionnaire. Table 7

Q. No	Yes		No		Total	
	No	%	No	%	No	%
31 Overall standard of efficiency opted for, completely understands and properly responds to spoken English	6	60	4	40	10	100
	a					
	6	60	4	40	10	100
	b					
32 Partially understands & responds to spoken English	6	60	4	40	10	100
	c					
	6	60	4	40	10	100
	d					
32 Partially understands & responds to spoken English	4	40	6	60	10	100
	a					
	4	40	6	60	10	100
	b					
32 Partially understands & responds to spoken English	4	40	6	60	10	100
	c					
	4	40	6	60	10	100
	d					

As could be judged from the results of employers' questionnaires, they tend in Q.31 to like optimal achievement. The majority are pro maximal levels. Whether this could be achieved or not is controversial. Writing about a similar topic Torbe, M. (1982:61) pinpointed the same thing. He wrote:-

"There are mismatches between what is practised...and what is required...The two main demands upon language in employment are for technical, job-specific applications, and for social and more generalised skills. Talk is immeasurably more common than writing or reading, and the range of writing or reading, tasks is more varied and is always for a wide range of purposes, and for real audience who do not 'mark' the writing but act upon it".

For the researcher, it is a matter that needs more than just giving views. Experience and practice have shown that setting maximum levels as target aims looks like crying for the moon. Yet one has to be hopeful. The researcher has recorded the views obtained during research. The majority 60% have opted for the maximal level in Q.31, whereas the minority 40% have opted for moderate levels in Q.32. Looking at the responses to Q.33, one can see that employers prefer to arrange the 4 skills giving priority to speaking, than writing, then listening and reading. They have their reasons for this sort of organisation. The researcher, would give precedence over other skills to reading. It may refer to his field of teaching to get to know more and the employers' field of practical experience which may be called target performance. The Table-7-on the previous page shows the results of both questions. As for Q.34 which is the last question in the questionnaire, one can say that it is very demanding as it asks for suggestions which require full comprehension of the E's roles as key figures, decision makers, and trustees who should always

look for the best in the world of business. It is of an open sort which the respondent or interviewee can write or say whatever he or she envisages as essential, helpful or even of a relevant nature. It, then, is the duty of the researcher to sift the views or suggestions and record those of real importance, of feasible nature and those that are or could well be practicable.

Six main points were emphasised by the majority 70% of respondents. They are put according to sequence and emphasis originally given by respondents.

- (i) There should be one common-core English course for all specialisations at the beginning of study.
- (ii) Communicative ESP courses should form the core of each and every specialisation.
- (iii) More ESP courses are needed for achieving better results on practical levels.
- (iv) More emphasis should be laid on the humanistic and social side of life while study is in progress.
- (v) Translation should be taught to students to help them make certain things easy and clear for themselves in the first place and for customers in the second.
- (vi) Maximum co-operation between and among various KBI departments on the one hand and among other departments and other Kuwaiti institutions on the other, is highly recommended for better pragmatic results.

4.3.3 Teachers' Questionnaire

As is the case in the employers' questionnaire, this also is in five sections and in almost every case covers the same grounds except that instead of the employers named in questionnaire 1, we now read 'Head of Department, Professor, Assistant Professor, Lecturer and Teacher', and instead of your official referred to there, we substitute 'your students'. Sixty full-time teachers of all disciplines were sent questionnaires and/or interviewed. Twenty of them with a special concern for Computer Science answered this questionnaire. Attention should be given to question 29 which is extra to the first questionnaire and asks for titles of 2-4 textbooks in English as course books or recommended ones, which means that students are asked to read or, at least, consult. The researcher will take texts-two chapters- from the books most frequently mentioned by both teachers and students, and analyse the contents, whilst also noting the way in which they communicate information. These analyses of Computer Science selected texts in the next chapter along with those of recorded lectures in Chapter Six show the interest in the research in Computer Science students.

Text analysis has been the tradition since Ewer and Lattore analysed a big corpus of science in the year 1969. Many attempts have followed. The King Abdul-Aziz University project participants did the same with spoken and written texts for undergraduates in Saudi Arabia in the years 1974, 1975 and 1976. Similar attempts have been reported in the faculties of Commerce (1979), Science (1979), Education (1980-1984), and that of Shari'ah and Islamic

Studies (1981-1984) in Kuwait University. Beedham and Bloor formerly of the English Language Studies Unit in Aston, Birmingham did the same with three computer science textbooks for overseas undergraduate students in 1980. This analysis of Beedham and Bloor is similar to ours in, the sense of the objectives of analysis being for ESP but it is surely different in the end-product because their final aim is EAP whereas ours is both ECP and for a minor part EAP.

To go back to the Teachers' Questionnaire, the rest of it follows the pattern of Questionnaire 1. Attention to the manner as well as the matter of coursebooks, which is implicit in Q.29 has become part of the 'field of discourse' material earlier indicated by Halliday, McIntosh and Strevens (1964:90):

"Field of discourse refers to what is going on: to the area of operation of the language activity. Under this heading, registers are classified according to the nature of the whole event of which the language activity accounts for practically the whole of the relevant activity, such as an essay, a discussion or an academic seminar, the field of discourse is the subject-matter. On this dimension of classification, we can recognise registers such as politics and technical registers like biology and mathematics".

Computer Science publications and practices have, undoubtedly, added to the scope and interest of such materials.

4.3.3.1 The demographic information collected through the first section of the T's questionnaire refers to the mean of their ages ranging between 38-44 years. The majority of the sample which consists of 42 or 70% are males and the rest - 18 - or 30% are females. The majority of the sample consists of 40 Egyptians or 66.7%, then 10 Jordanians 16.65%, then Kuwaitis 16.65% or 10. The majority

75% or 45 are on personal contracts; they are employed by the Authority for Applied Education and Training. This PAAET has recently taken over The Directorate for Technical and Vocational Education. The teachers' responsibilities range from materials writing and teaching to measurement and evaluation as the natural end of teaching learning process. The word research has not occurred as it should.

To come back to the sample of the population; it consists of 20 teachers of Computer Science, 20 teachers of English and the rest are teachers of various disciplines such as Accounting, Business Administration, Insurance, Banking etc. Fifty out of 60 or 83.33 have post-graduate qualifications. Two thirds of the sample as one can perceive are directly related either to Computer Science or English Language Teaching which form the core of this thesis. Their experience and expertise will certainly enrich the research, as the mean of their experience is fourteen years.

4.3.3.2 The second section II is concerned with the need for English and the levels of proficiency required in the four skills, the ordering of such skills according to importance as envisaged by the T's interviewed and/or sent questionnaires. The result of Q.10 shows that all the teachers agree to the need for English; 75% of them opted for often and 25% for sometimes. The results of questions 12-15 are in the following Table 9.

Q.No 10 : Are your Students required to use English. Table 8.

Yes	Cften		Sometimes		No	
	No	%	No	%	No	%
60	100	45	75	15	25	-

Responses to Some Questions in Section II of the T's questionnaire Table 9.

No.	A = Excellent		B = Very Good		C = Satisfactory		Total	
	No	%	No	%	No	%	No	%
11	-	-	40	66.67	20	33.33	60	100
12	-	-	40	66.67	20	33.33	60	100
13	20	33.33	30	50	10	16.66	60	100
14	5	8.33	45	75	10	16.66	60	100

- 11 How should the graduates level of understanding spoken English be?
- 12 How should his speaking skill be?
- 13 How should his reading skill be?
- 14 How should the writing skill be?

As for Question 15, 66.67% said no and wanted the four skills, answer of 16, to be reorganised as reading, writing speaking and listening, whereas the rest accepted them as listening, speaking, reading and writing.

Table 10

Q.No 15. Should proficiency in receptive skills and productive skills be equal

Yes		No	
No	%	No	%
20	33.33	40	66.67

4.3.3.3 The results obtained in Section III of the Teachers' Questionnaire appear in Table 11:-

Table 11 Shows Tabulated Results of Section III on
Tasks to be Accomplished in English of the T's Questionnaire

Table 11

No.	Task	Always		Often		Sometimes		Never		Total		
		No	%	No	%	No	%	No	%	No	%	
17	The student is to use his receptive understanding skills with a his boss/teacher b his colleague c his subordinate d his client	40	66.67	10	16.67	10	16.67	-	-	60	100	
		10	16.67	10	16.67	40	66.67	-	-	60	100	
		-	-	-	-	-	-	-	-	-	-	-
		-	-	-	-	-	-	-	-	-	-	-
18	The student is to use his spoken English when :- a receiving/giving reports b asking for/giving information c asking for/giving explanations d holding meetings	5	8.33	50	83.33	5	8.33	-	-	60	100	
		5	8.33	50	83.33	5	8.33	-	-	-	-	
		5	8.33	50	83.33	5	8.33	-	-	-	-	
		-	-	-	-	-	-	-	-	-	-	-
19	The student is to read English when: a taking instructions/circulars b handling correspondence/circulars/ mail (reading) c issuing instructions and holding meetings d directing transactions e handling orders	10	16.67	40	66.67	10	16.67	-	-	60	100	
		-	-	40	66.67	20	33.33	-	-	-	-	
		-	-	40	66.67	-	-	-	-	-	-	
		-	-	20	33.33	40	66.67	-	-	-	-	
		-	-	50	83.33	-	-	-	-	-	-	
20	The student is to be familiar with certain terms necessary for his job a idioms & acronyms related to his job b Figures, tables, charts & diagrams c proper channelling of certain trans- d actions	50	83.33	10	16.67	-	-	-	-	60	100	
		50	83.33	10	16.67	-	-	-	-	-	-	
		50	83.33	10	16.67	-	-	-	-	-	-	
		-	-	10	16.67	40	66.67	10	16.67	-	-	

The options of these questions range from Always, often, sometimes to never. The last question is a little bit different; it asks for more flexibility. The need for receptive understanding, speaking and reading is clearly spelled out in the results under 'often' except in the last questions where knowledge and utilisation of relevant idioms, terminology, proper channelling and familiarity with figures, charts, diagrams etc. is of paramount importance.

4.3.3.4 This section IV lends itself to deciding the need for English in performing tasks and job responsibilities; whether the English they received instruction and training in was enough for their present and future needs as both students and officials in medial positions.

Table 12

	Yes		No		In Some Cases	
	No	%	No	%	No	%
21. What do you think of your students' training in English at KBI; has it been sufficient to meet the job demands	-	-	40	66.67	20	33.33
22. Does/did he/she need further training in English	40	66.67	-	-	20	33.33

The majority or 66.67% or 40 were for its not being enough and the others 20 or 33.33% were for its being satisfactory only in some cases. All of them were in favour of change.

The responses for the next 22 were of similar or identical nature to those in 21. In fact they should be so since they are a natural result.

The next Q. 23 asks for only one of two options being 'yes' and 'no'; it also asks for re-ordering of need in the four skills for in-service training. The majority or 66.67% see that there should be reordering which takes the following form on a descending scale - reading, speaking, listening and writing. This shows that T's are not consistent in answering the questions altogether. It was not so in the second section.

The need for training in the four skills has been given prominence. 10 or 16.66% see it as essential, while 40 or 66.67% see it as very important yet the other 10 or 16.66% see it as important. All of the teachers see that there is need for English and that there is need for training in it; that is claimed as very important by the majority.

In Q.25 a great majority 50 T's or 83.33% see that there is need for regular training. This majority is nearly echoed in the responses to the next question; 45 or 75% see that graduates needed further training to perform efficiently; the other 25% or 15 see it otherwise.

The responses to Q.27 show that texts in another language are recommended materials for the course the other language has been in and I am of the view that it will be of primary importance. By this I mean the English language which has acquired the status of both the business lingua franca and the unofficially acknowledged second language in Kuwait and the Arab Peninsula. The status of this foreign language -English - being so, is a sort of answer to both questions 27 and 28. For English is being taught first as

English Language; some nine different English courses are being taught these days and second it is being used as a medium of instruction e.g. in some Computer Science, Banking, Medical Secretaryship, Insurance and Accounting in English. The uses to which English can be put, as could be seen from the previous remarks, are diversified and this we are sure highlights the answer of Q.28. It should be remembered that it is an instrumental use, for achieving a purpose and not an integrative one.

In answering question 29 Teachers have mentioned 4 books:

1. Information Data Processing - Fourth Edition, -
Marilyn Bohl - SRA Science Research Associates 1984.
Printed in America (USA).
2. Standard COBOL : A problem-solving Approach - 1971 -1974
Marilyn Z Smith, Houghton Mifflin Company - Boston.
3. Modern Business Data Processing, Daniel D Benice, 1973 - 1975
Printice - Hall Inc. Printed in the USA.
4. Computer Appreciation. T.F.Fry, Newnes-Butterworths 1975
London - Boston. Printed in England

In fact the last two questions 29 which asked for the above mentioned textbooks and Q.30 which asked about the 'usefulness' of English were different. The latter question achieved the rate of 75% or 45 T's who considered English as 'very useful', 13.33% or 8 considered it 'useful' and 6.66% or 4 said it was 'not very useful' and the rest 5% or 3 considered it as 'not necessary'. The majority or more than 88% see English as 'Useful'; more than enough to resort to English and utilise it as the foreign language for business and the lingua franca referred to before.

Table 13

Table 13: Tabulated responses to some questions in Section IV

Q.No	Yes		No		In Some Cases		Total	
	No	%	No	%	No	%	No	%
23.	20	33.33	40	66.67	-	-	60	100
25.	50	83.33	10	16.67	-	-	60	100
26.	50	83.33	10	16.67	-	-	60	100
27.	45	75.00	15	25.00	-	-	60	100
28.	57	95.00	3	5.00	-	-	60	100

23. If you answer to (need for further training) was 'yes' what language skills does he need to be trained in? a- Equally in the four skills?
25. Does he/she need regular training to cope with up-to-date techniques?
26. Did he need in-service training when he started his job?
27. Are texts other than Arabic recommended reading materials for the course?
28. Do you think your students could gain anything from knowing a foreign language?

Table 14

Very Useful	Useful		Not Very Useful		Not necessary		Total	
	No	%	No	%	No	%	No	%
45	8	13.33	4	6.66	3	5	60	100

30. How would you describe the usefulness of English to be a well-qualified graduate in computing ?

4.3.3.5 The last Section V is of a general nature. It asks for the arrangement of a scale of options the teacher opts for. While 50% in Q.31 want efficient understanding of written English-33.67% want efficient written communication and the rest is equally divided between efficient oral communication and complete understanding of what is spoken. Yet the responses to Q.32 are a bit different; 40 or 66.67% prefer satisfactory understanding of what is spoken. Concerning oral communication, it goes 50% each for 'satisfactory' and 'efficient' communication. As for reading, it is similar to that in the previous sentence. Though the case for writing is very near to that of reading, 83.33% opt for accurate writing - being teachers they opt for the optimal - and the rest are for satisfactory.

Table 15

	Yes		No		Total	
	No	%	No	%	No	%
a	30	50	30	50	60	100
b	10	16.67	50	83.33	60	100
c	30	50	30	50	60	100
d	20	33.33	40	66.67	60	100
a	40	66.67	20	33.33	60	100
b	30	50	30	50	60	100
c	30	50	30	50	60	100
d	50	83.33	10	16.67	60	100

31. Overall standard of Efficiency you Opt for in KBI graduates.
- a Completely understands & properly responds to spoken English
 - b Communication Efficiently in spoken English
 - c Reads & understands efficiently written "
 - d Writes accurately & to the point in "
32. Partially understands & responds to spoken English.
- a Communicates satisfactorily in spoken English
 - b Reads & satisfactorily understands written English
 - c Writes highly communicative English

The arrangement of skills asked for in Q.33 goes a little bit in the direction of Q.32: emphasis is being laid on reading as most important, then writing, then speaking and last is that of listening.

The respondents may have deviated, but it is the way T's see it. In fact they want to lay emphasis on the teaching of skills others do not or even cannot provide. In the long run, this will surely equip the learner with strategies and know-how which may continue to be helpful all through learners' lives. Teachers are sure to have their convincing justification.

The open-ended sort of question provided at the end of the questionnaire has enriched the responses. A variety of suggestions were obtained through respondents. Such suggestions are similar to the researchers' views concerning the need for a common core course, ESP, English for social purposes, co-operation, more hours, research and teacher training. These responses obtained through T's are also similar to those of the employers. Though E's tend, as a general trend, to prefer speaking to reading and writing in which teachers do the opposite, the latter seem to come to a sort of agreement in putting forward their suggestions. Anyhow difference in opinions is a healthy sign. It only refers to shifting importance or throwing the necessary light to have a better view of an object.

The following are the important suggestions given by teachers.

- (i) There is need for a general Remedial English Course for a majority of the newly-accepted students.

(45 T's support this view.)

- (ii) There is need for communicative ESP courses for all specialisations, each in its own disciplines.(40)
- (iii) More contact hours and eventually more credits should be allotted to ESP courses as this promotes both students performance in both English and specialism as well.(40)
- (iv) Translation should form a component of each ESP course since it is there in target performance(40)
- (v) More emphasis should be laid on reading and writing skills for promoting target performance. This necessitates a minimum structural basis, at least.(40)
- (vi) Co-operation between and among the departments of KBI is highly recommended, since it is thought to yield the best output for both teachers and students. (45)
- (vii) English for social purposes is worth giving more emphasis in any course design.(40)
- (viii) Computerised self-aided programs are advisable as electives. (50)

We will comment on these suggestions later when we present the Graduates' Questionnaire.

- (ix) Research should play a leading role in devising courses and in teaching.(48)
- (x) Teacher training should be given a paramount role in the preparation and selection of teachers for KBI and other PAAET institutions. (45)

- (xi) The use of non-linear texts is highly valuable in spite of any cost or financial impediments. (40)
- (xii) Occasional development or restructuring of courses in the light of feedback is highly recommended for a more effective teaching-learning output and for debugging any course or language teaching program. (40)

4.3.4 Now we move to the Graduates' Questionnaire. The total number of students then - October 1984 - was 2,331. They occupied two campuses. We divided the total population into two and worked with the supposition that half the number 1,165 would be justifiable. The choice of subjects was on random bases. The 165 graduates was a random sample. They were sent questionnaires and or interviewed. 15 failed to respond for various reasons, so the number that really contributed was 150. It is the sample that we will be dealing with. The original number - 165 - comes up to a little more than 14% which is a reasonable sample according to internationally accepted standards, as in Van Dalen; previously quoted.

It could well be argued that the number 1,165 included expatriates and scholarship holders which is usually 15% of the intake. This reduces the number of the population to nearly 1,000. If the percentage of the respondents number is taken, it will be a little above 15% which is also an acceptable sample.

4.3.4.1 Now we move to Section I of the Graduates' Questionnaire. The demographic information collected from the sample of the population refers to the homogeneity of the sample. Twelve graduates or 8%

of the sample were non-Kuwaitis but were working in Kuwait. The mean of ages ranged between 21-28 years. Forty percent of the sample consisted of males and the rest were females. Eight percent were university graduates which is 12. It is worth mentioning that recent graduates tend to pursue their higher studies more than older ones. The jobs graduates in this sample held ranged from public to joint and private sectors. Most of these have their own branches, units, divisions and or correspondents in Kuwait and abroad. The responsibilities of graduates-officials - differed in range and nature from one institution or concern to another. But it mostly was related to computing in particular and/or business or business-related work in general. Work mostly dealt with operating, programming, analysing and other relevant operations. Some graduates have achieved positions of heads of sections or departments at a rate faster than that of some Kuwait University graduates. All concerns whose KBI graduates have been interviewed had at least two branches and thirty four at most.

Table 16

Responses to Some Questions in Graduates Questionnaire Section I : Personal

Q.No.	Information Required	Responses	
		21-28 years	Mean of ages
2a b	Age Sex	60	M
		90	F
3	Nationality	138	Kuwaiti
		12	Non-Kuwaiti
4	Education	12	B.A./B.Sc
		138	KBI Graduate
7	Legal Status	60	Public Private Common } Sector
		30	
		60	
8	Responsibilities	10	Key position
		140	not in key position
			6.66%
			93.34%

4.3.4.2 The result of the first question in Section II - including 10-16 - was 92%; it shows the percentage of those who admitted their need for English. They were divided into two categories of those who need it 'often'; 62% and those who need it 'sometimes' 30%.

Aggregate Response :

Table 17

Q.No.11 Are you Required to use English?

Yes		Often		Sometimes		No	
No	%	No	%	No	%	No	%
138	92	93	62	45	30	12	8

As for Q.15 forty of the respondents agreed to equal emphasis but the rest - 60% - differed. The latter group wanted it to be speaking, reading, listening and writing. Concerning the responses to question 11-14, they appear in the following table:-

Table 18

Aggregation of Responses to Questions 11-14 of Section II of G's Questionnaire

Q.No	Excellent		Very Good		Satisfactory		Total	
	No	%	No	%	No	%	No	%
11	20	13.33	100	66.67	30	20	150	100
12	15	10	105	70	30	20	150	100
13	30	20	90	60	30	20	150	100
14	30	20	75	50	45	30	150	100

- 11 How should the G's understanding of spoken English be?
- 12 How should his speaking skill be?
- 13 How should the reading skill be?
- 14 How should the writing skill be?

The results above show the tendency towards the 'Very Good' standard, in the four skills. Graduates' ambitions do not soar extremely high but need to have the 'Very Good' standard by which they can shoulder their responsibilities. Though they tend to lay more emphasis on speaking more than other skills, there is such a correspondingly high rate of interest in reading and writing in the responses to question 16. This means that the Sample Graduates feel they need speaking more than the other skills. Yet they see the excellent standard in reading and writing also important.

Aggrerate Response :

Table 19

Q.15 Should proficiency in receptive and productive skills be equal?

16. How would you rank the four skills?
a-speaking, b-reading,
c-listening, and d-writing

Yes		No	
No	%	No	%
60	40	90	60

All the sample prefer the 'Very Good' standard. They all shift points of interest. Employers and G's stress speaking as most important but they with the Teachers see reading and writing as very important. Academics and practitioners give priority to reading and writing and they have their justification.

4.3.4.3 We now move to Section III of the Questionnaire which comprises four questions; 17-20 respectively. This section is similar to those sections of the other two questionnaires. The following Table 20 shows responses to Section III of the Graduates' Questionnaire.

Aggregate Response to Section III of the Questionnaire

Table 20

Q.No	Always		Often		Sometimes		Never		Total	
	No	%	No	%	No	%	No	%	No	%
17 The graduate is to use his, receptive understanding skill with:	15	10	90	60	45	30	-	-	150	100
	15	10	50	40	75	30	-	-	150	100
	15	10	75	50	60	40	-	-	150	100
	15	10	75	50	60	40	-	-	150	100
18 The graduate is to use spoken English when:-	15	10	90	60	30	20	15	10	150	100
	15	10	90	60	30	20	15	10	150	100
	15	10	90	60	30	20	15	10	150	100
	15	10	30	20	90	60	15	10	150	100
19 The graduate is to read English when:-	30	20	78	52	30	20	18	12	150	100
	30	20	40	42	28	18	12	12	150	100
	30	20	60	40	42	28	18	12	150	100
	30	20	60	40	42	28	18	12	150	100
	30	20	60	40	42	28	18	12	150	100
20 The graduate is to be familiar with:-	90	60	33	22	15	10	12	8	150	100
	90	60	33	22	15	10	12	8	150	100
	90	60	33	22	15	10	12	8	150	100
	90	60	33	22	15	10	12	8	150	100

The results of questions referring to the four skills refer to the 'Often' option in listening, speaking and reading. A little less goes to 'Sometimes'. The other extremes of 'Always' and 'Never' have narrower possibilities. These range from 0% to 8% at times, 10% or 12% at most in others. This shows that all skills are needed but with a shift of emphasis. More emphasis is laid on the 'Always' option concerning the knowledge and acquisition of specialist idioms, terminology and the know-how. This clearly points out the fact that G's are well aware of what and how much they should know when it comes to ESP or their specialisms. Such views are well worth considering by any researcher.

4.3.4.4 The responses obtained in Section IV of the Graduates' Questionnaire are very rich indeed. The section includes questions 21-30. ten questions in all. Questions 21 and 22 ask for responses by offering three options of 'Yes', 'No' and 'In Some Cases'. Whereas others like 23,25,26,27 and 28 offer only the former first two options of 'Yes' and 'No', ranking the need for in-service training exists in question 24 and the enquiry about texts or references exists in question 29. The enquiry about the usefulness of English exists in the last question: 30. It allows four options of 'Very Useful', 'Useful', 'Not Very Useful', and 'Not Necessary'. The reader, of this section, will understand its wide perspectives, as this section includes a question about the need for English Language, training in English and its usefulness. It also asks about the favourite order of the four skills; the benefits ensued, the need for up-to-date techniques and the use of English as a foreign language. Thus one can see the wide range of topics and

options tackled through the questionnaire as a whole. The following table No. 8 shows the results of this section.

Table 21

Results of Section IV of the Graduates' Questionnaire

Q.No	Yes		No		In Some Cases		Total	
	No	%	No	%	No	%	No	%
21	12	8	90	60	48	32	150	100
22	90	60	12	8	48	32	150	100
23	60	40	90	60				
25	135	90	15	10				
26	135	90	15	10				
27	138	92	12	8				
28	138	92	12	8				

Q.No

21 What do you think of your training in English at KBI; has it been sufficient to meet the job demands?

22 Do/did you need further training in English?

23 If Yes; to previous question, What Language skills & activities did you need to be trained in?

25 Do you need regular training to cope with up-to-date techniques?

26 Did you need in-service training before you started your job?

27 Are texts in a language other than Arabic recommended reading materials for the course?

28 Do you think you could gain anything from knowing a foreign language?

We now move to q.24 which asks for ranking need for in-service training. This was given four options of 'Very Important', 'Important', 'Not Very Important', and 'Not Necessary'. Responses were mostly of the 'Very Important' option; 105 or 70% chose this option, while 30 or 20% opted for 'Important' and the rest or 15 which equals 10% opted for 'Not Necessary'.

This result strikingly shows the necessity for training which equips G's and would-be graduates with work experience; a key for assured success. This same issue was emphasised by J.Rushing, in 1983, while heading a self-study consultant American team.

The other extreme which opted for 'Unnecessary' is equal to ten percent. They envisaged that option for more than two reasons. The first is that the respondents had been employed, before joining KBI, in marginal jobs like clerks and non-skilled workers. Such jobs could be carried out as routine work which needs no effort or improvement. The textbooks specified by the graduates are the following:-

1. Computer Appreciation T.F.Fry Newnes-Butterworths
London - Boston 2nd edition 1975.
2. Modern Business Data Processing. Daniel D.Benice
Prentice Hall-Inc. 1973-1975. Printed in the USA
3. Standard COBOL - A Problem - Solving Approach. Marilyn Smith
Houghton Mifflin Company 1971-1974 Boston
4. Information Data Processing. Marilyn Bohl SRA Science
Research Associates. 1984 Printed in the USA

These books have been dealt with both as textbooks and or recommended ones. Some referred to an Arabic textbook having the title 'Introduction to Computing with BASIC' by Dr.M.Alfayyomi. When enquiring about the book, the researcher was told that it had recently been approved by the Academic Affairs Committee as a textbook for mere beginners.

Table 22.

6.30 How would you describe the usefulness of English for a graduate to be a well-qualified professional in Computing?

Very Useful		Useful		Not Very Useful		Not Necessary	
No	%	No	%	No	%	No	%
90	60	30	20	18	12	12	8

The last question asking about the usefulness of English yielded nearly similar responses to the same question in both the E's and the T's Questionnaires. Eighty percent or 120 graduates see English as 'Useful' with 60% of these who see it as 'Very Useful'. The rest is divided into two lots: Those who see it as 'Not Very Useful' are 18 or 12% and 12 or 8% see it as 'Not Necessary'.

4.3.4.5 The last Section V of the Graduates' Questionnaire asks for 'Overall Standard of Efficiency of KBI Graduates' they opt for and consists of four questions. The first two ask for expected standard opted for in the four skills. The results shown have been equally balanced in both questions. It was 75 or 50% for the completely efficient performance in the four skills .

When it came to laying emphasis on any of the four skills, there occurred some shift of emphasis. Graduates opted for oral communication followed by reading, listening then writing. This sounds very similar to Employers' views but different from Teachers' views which lay emphasis on the need for reading followed by writing. This goes back to the result of the evaluation and assessment of communicative language teaching whose results improved pupils' oral communication but showed mediocre level in written communication. Thus teachers may be described as trying to pull the strings of the four skills together, to obtain equilibrium in efficiency and in giving proficient graduates as output. Table 23 shows the responses to Qs. 31 and 32 of Section V:

Table 23

	Yes		No		Total	
	No	%	No	%	No	%
	75	50	75	50	150	100
	75	50	75	50	150	100
	75	50	75	50	150	100
	75	50	75	50	150	100
	75	50	75	50	150	100
	75	50	75	50	150	100
	75	50	75	50	150	100
	75	50	75	50	150	100
	75	50	75	50	150	100
	75	50	75	50	150	100
	75	50	75	50	150	100
	75	50	75	50	150	100

Q.No

31 Overall Standard of Efficiency of KBI Graduates you opt for.

Completely understands & properly responds to spoken English

Communicate efficiently in spoken English

Reads & understands efficiently written English

Writes accurately & to the point in English

a b c d

32 Partially understands & responds to spoken English

Communicates satisfactorily in spoken English

Reads & satisfactorily understands written English

Writes highly communicative English

a b c d

The last question is an open-ended but necessary one to glean ideas, expectations and future projections of students who have gone through the learning experience plus training processes. Graduates have spelled out their ideas. In a way they were similar to teachers' views with certain amount of shift of emphasis from reading and writing to oral communication.

In their suggestions the Graduates were of the view that future graduates need the following:-

- (i) a GPE course specially devised with KBI entrants in mind so as to serve as a preparatory course; 90; or 60% suggested this;
- (ii) communicative ESP courses in different specialisations mindless of financial cost; 120; or 80% ;
- (iii) proper and adequate use of translation from English to Arabic and vice versa, 105, or 70%;
- (iv) a minimal basic knowledge of grammar to help accurate and proper oral and written communication. 96 or 64%;
- (v) co-operation between and among various KBI departments is a must for orchestrated performance, 100 or 66.67%;
- (vi) more training in English is highly recommended, 120 or 90%;
- (vii) a point ensued by the one above is that more contact hours or unit credits are required; and

(viii) the more motivating courses are, the more effective and fruitful they would be. 105 graduates suggested this which is equal to 70%.

4.4 General Evaluation of the Results of Questionnaires in relation to Stated Objectives.

The questionnaire as a successful research tool can hardly be denied its importance. That is one of the reasons why we use it in this research. The general objectives behind using it (mentioned in 4.1.1) have been very demanding.

As for (a) or investigating the opinions of the E's, T's and G's concerning the appropriateness of ELT courses used in KBI and their objectives, this has been done. The information obtained showed dissatisfaction of E's, T's and G's through their asking for more ESP courses and more training in English as well. The number of the sample population e.g. 10 E's and 60 T's and 150 G's, makes the information obtained very effective as the sample groups are directly and effectively involved in ELT or rather ESP courses and study skills as instructors to students whose learning experience and achievement will be tried out by the E's who are usually very careful about their establishments and their promotion. We refer, in this respect, to sections 4.3.2.1, 4.3.3.1 and 4.3.4.1 which emphasise the homogeneity of the samples and the context of work the thing which leads to uniformity of results, of course, with some difference due to private nature of a subject, job or establishment.

Regarding (b) which refers to presenting an evaluation of the satisfaction of the E's, T's and G's with what is currently offered, information from the questionnaires has shown dissatisfaction of the three groups - a majority of them - and by majority we mean a percentage of 60% or above - have asked for more ESP courses, shift of emphasis on skills and the inclusion of needs analysis as a basis for designing courses for KBI students. The need for training for the job and the demand for subject-specific courses to be taught in English. (Sections 4.3.2.5, 4.3.3.5 and 4.3.4.5 give a clear overview of the existing dissatisfaction).

For (c) or articulating the needs of the groups and what they want in officials, students and in themselves in, the answers were in favour of efficiency in specialisation and relevance to time allotted for courses, to subject matter, to pedagogical, communicative and pragmatic bases. This can be clearly seen in Section III of all the questionnaires which is entitled 'Tasks to be Accomplished in English' and whose results exist in 4.3.2.3, 4.3.3.3 and 4.3.4.3 and the relevant tables to these sections.

Concerning (d) or eliciting information about the sample populations...the information elicited reflects the importance of the information and those who gave it. Bankers, Civil Servants, Teachers, Graduates in situ and other kinds of businessmen have promising opportunities for KBI would-be-graduates. In this the importance of their demographic information concerning academic and occupational matters lies. We can see this in sections 4.3.2.4, 4.3.3.4 and 4.3.4.4 and the relevant tables which show

the information in tabular forms that are easy to handle and understand.

While (e) aims at presenting the information in tabular forms to be easy to handle and understand, (g) aims at establishing data which will allow comparisons, contrasts and so on. We find this in the tables we presented; those having nos 1-23 which reflect the views in both figures and percentages. Where there is richness, diversity or any other phenomena these can be easily perceived by the reader. The majority of the sample populations, for example, agree on the unsuitability of existing ELT materials used in KBI. The majority also agree to communicative language teaching. The majority are engaged in business or business related activities. But there is difference - contrast - in views concerning the arrangement of the four skills between T's and G's. The former group wants it to be reading, writing listening and speaking, whereas the latter prefer it speaking, reading then listening and writing.

Relating to this subject of skills and communication skills in particular, of their usual arrangement and how they should be arranged in terms of importance or emphasis Chambers R and Longman K (1982:103) wrote a- about the inclusion of the enabling or communication skills:-

"The most frequent communication skills are those which involve the capacity to listen, ask appropriate questions appropriately, carry out instructions, convey spoken information, and transmit written data in some form, for a simple memorandum to be abstracted in technical information".

They also wrote - b - about the ordering of the skills in general:-

"An interesting point is that the skills identified in the above few lines are in order of importance and order of use, i.e. listening skills are most important and most frequently used and needed-written skills least so. Yet in most schools and colleges the reverse emphasis applies".(Op.Cit)

That means the writers' (Chambers and Longman) observations are right as far as T's views are concerned; because they - T's - arranged the skills as reading, writing, listening and speaking according to importance.

Objectives (f) or gathering information for specifying needs and (h) or establishing a basis in documented evidence for ELT materials evaluation...have been achieved. A general look at the responses to some questions in section IV of the questionnaires tell us clearly about the need and the usefulness of English for a graduate to be a well-qualified professional in computing. Even before that it tells us about the need for a foreign language - English - agreed upon by 92% of the sample populations. The need for further training in English is widely expressed. The need for knowledge of terms idioms, acronyms, figures, charts, diagrams etc. necessary for the job beside a knowledge and familiarity with the proper channelling of transactions have been clearly spelled out by an overwhelming majority of E's, T's and G's.

Spelling out the needs of the sample populations is one stage in the research and implementing them through using them as a documented basis for demanding change is another. The (f) and (h)

objectives have already been achieved.

Regarding (i) or gathering evidence as a basis for further suggestions, to be used in relating the broad needs analysis and and the designing of courses for KBI students, in particular computer science students the researcher has demonstrated the evidence - respondents' views-in more than twenty tables. The researcher has also asked more than one question relating to skills in general, and their order or arrangement, specific skills, some enabling skills, familiarity with subject - then job-related terminology, suitability of existing training, need for more training and the suggestion of 2-4 computer science textbooks recommended for reading or dealt with as textbooks. Thus all objectives have been met relating to the theoretical parts of the Thesis.

This narrows down the scope of the research to computer science courses. The researcher believes that the specific objectives of the various sections of the questionnaire have also implicitly been achieved, especially that of creating a documented basis for the evaluation of existing EIT courses and the establishment of a basis for including other views in the case of new ESP course design.

4.5 Conclusion

It is argued that the results provided by the questionnaire lead to the possibility of establishing the following database, providing guidelines for EIT course design within KBI or similar ones of a relevant nature.

- (a) Materials provided should be based on a clear analysis of needs. A needs analysis that takes into consideration views of the E's, T's and G's and in suitable context. Such materials emanating from a broader needs analysis, as we have suggested, should be suitably sequenced concerning their linguistic and disciplinary content. This result supports our idea about the broader needs analysis and ESP theoretical principles tackled earlier in Chapter Two.
- (b) Specificity and suitability to discourses of relevant disciplines studied have been approved of by E's, T's and G's. These characteristics further the interest of students in authenticity and in the discipline that is being taught. These characteristics also support the criteria we adopted in Chapters Two and Three.
- (c) Concerning methodology; teaching for communicating in various specialisations is envisaged as the most suitable by E's, T's and G's. This entails pedagogic planning for pragmatic validity and motivation.
- (d) Proper teacher training for shouldering responsibilities has been viewed through the call for co-operation between and among KBI departments for collaboration on a mutual basis. Such policies are essential for the success of any ESP course.

Moreover, this database needs to be added to in the next two Chapters. In fact, more than four methods of eliciting and collecting information have been utilised at various times. First the survey and discussion of ESP theoretical principles. Second a questionnaire has been used with samples of three different populations. A constructed interview was brought in, as a variable of the questionnaire, where the researcher saw necessary to bridge any gaps in the information eliciting process. Analysis of computer science texts will be carried out in Chapter Five for getting to know functional relatively linguistic, as well as textual and discoursal organisation as third. Fourth, visits to classrooms and offices have been paid for purposes of gleaning information in situ; this has been called 'Means Analysis' by Adrian Holliday (1984:29-51). Analysis of recordings will also be carried out in Chapter Six, whose results will hopefully help in supporting our views concerning broader needs analysis which will include a triumvirate of opinions.

Text Analysis As a Contribution to Needs Analysis for ESP

'The main direction of the development of Linguistics as a separate discipline has been from phonology (in the 1930's) through morphology and syntax to discourse. This direction has been founded on what may be loosely called "the referential function of language". '

(Hymes 1980 : viii)

TEXT ANALYSIS AS A CONTRIBUTION TO NEEDS ANALYSIS FOR ESP

5.0 Introduction

Philosophers, critics, preachers, linguists, language teachers and course designers have been engaging in analysing texts or discourses. They have been engaging themselves in this sort of activity in order for them to find or adopt an approach, a model or a theory based on a principled framework or a documented basis. Such a theory or principled framework would surely contribute to a better understanding of texts or discourses e.g. in a certain discipline for more appropriate ESP courses.

5.1 The following objectives have been set out for this chapter:-

- (a) To present different definitions of the words 'text' and 'discourse' from important contributors to the field.
- (b) To expound salient features in the development of text and discourse analysis with a view to identifying those approaches which can usefully contribute to the analysis of computer science texts which is part of this chapter.
- (c) To consider approaches adapted to text analysis for ESP purposes.

- (d) To give an analytical account of an approach to the analysis of texts and textbooks.
- (e) To evaluate a commercially available ESP textbook. i.e. English for Computer Science.
- (f) To analyse two chapters from two computer science textbooks used in KBI, adopting an approach which incorporates elements from several models reviewed in earlier sections.
- (g) To establish a documented systematic basis of data for the inclusion of text analysis in the process of needs analysis as a prerequisite issue in course design for KBI Computer Science students in particular and for KBI students of other specialisation in general. The results will become suggested specific content for inclusion in the linguistic and functional content of ESP courses.

5.2 Definitions of the Words 'Text' and 'Discourse'

Many writers have tackled the words 'text' and 'discourse'. Each one demonstrated one or more than one perspective. Among those interested are Anwar, M.S., Flowerdew, Widdowson, Hoey, Stubbs, Stern, Abbot, Wingard, Greenwood, Poythress, Hatch, Long, Gumperz, Hymes, Austin, Searle, Coulthard and Halliday. We will demonstrate their definitions.

The definition of the word "text" as given by Halliday, M.A.K. and Hasan, R. (1976:1) is that of 'a Unit of language in use' as pointed out in the second chapter of this thesis, it is 'a semantic

unit' 'spoken' or 'written' transcending the structural unit which also holds together with other units through cohesion or cohesive devices. These devices along with the sentences or what Halliday calls clauses - others call them utterances - form the text which should be meaningful. The interweaving of clauses, utterances and or sentences - the texture - makes a text what it is.

We can say that Halliday's is a sociolinguistic and literary perspective.

Coulthard, M.

Coulthard (1977:17-18) referred to discourse analysis and pointed out that Austin had stated '.... in issuing an utterance', a speaker can perform three acts, simultaneously:

- (a) locutionary act or he said to me 'do something';
- (b) illocutionary act or he urged me to do something; and
- (c) perlocutionary act or he persuaded me to do something.

Austin and Searle

Austin and Searle dealt with speech act philosophy. By the former about 1000 illocutionary acts were suggested and divided into five major classes:-

- (a) Verdictives,
- (b) exercitives,
- (c) commissives,
- (d) behabitives, and
- (e) expositives.

Austin's and Searle's approach is from a philosophical perspective.

The bases of speech acts based on philosophical principles came to fruition by allowing more discussions and researches by others who followed the steps of Austin and Searle.

Hymes had used speech event in preference to speech act of Austin and Searle.

Gumperz and Hymes

Gumperz (1977:17) in Diana-Larsen Freeman (1980:10) notes that:-

"members of all societies recognise certain communication routines which they view as distinct wholes, separate from other types of discourse characterised by special rules of speech and non-verbal behaviour, and often distinguished by clearly recognised openings and closings."

Hatch and Long gave a definition of text. They wrote:-

"...it is a natural piece of discourse, such as arguments, complaints, recipes, jokes and story-telling sequences etc."

These usually form the Communicative events. Halliday believes the functions of a text may be realised in one of three macrofunctions of language Halliday had decided on. Moreover one text may realise more than one function. These do not belong to the grammatical categorisation of language. They are semantic and convey a function while having grammatical realisations:-

- (a) the ideational,
- (b) the interpersonal, and
- (c) the textual.

Any user is free to 'opt for' any function according to his own option. Although the mother child examples represent micro-functions addressed to the child by the mother are more in number than the adult's three macrofunctions, still we can say that the adult's sociolinguistic world is richer, and his repertoire is wider. His range of discourse is wider. As Halliday (1973:24)

himself put it:

"Adult language comprises more speech events than children's language, syntactically, socially and sociosemantically. The adult has more meaning potential".

Using a limited grammatical form to refer to one function may contrast with communicative processes and their realisations.

Hatch, E. and Long.

Hatch and Long (1980:15) again consider discourse as both spoken or written. The former is considered as ordinary unplanned discourse and the latter as planned one. They mention Selinker, Trimble and Trimble and Mountford as interested in overall discourse rather than sentence features to determine what materials ought to be developed for teaching English to science majors whose native language is not English. Hatch and Long considered discourse from learning-teaching perspective.

Poythress, V.S.

Poythress, V.S. (1980:281) wrote about discourse and quoted Pike (1967:37-72) who defined it as '...an emic unit of human behaviour'. But Poythress himself defines discourse from three angles:-

- (a) from the static perspective, the discourse as a whole, '...a chunk distinguishable from its context.';
- (b) from the dynamic perspective; a discourse is '...an instrument in a process of communication and change'; and
- (c) from the relational perspective, 'the same discourse owes its significance to a complex of relations to a whole culture'.

Summarising his views Poythress wrote:-

"In short, a discourse can be viewed as a fixed whole (static), as a human process (dynamic), or as a system defined in relation to culture (relational)."

Poythress considered discourse from a religious perspective.

Greenwood

Greenwood (1981:100) gives the following definition of a text:-

"A text will consist of discourse i.e. combination of interrelated sentences".

A discourse may be a text and a text may form a discourse.

In other words both discourse and text are generally interchangeable.

Greenwood clarifies it further:-

"This combination of sentences - is formed in various ways. For instance the words will belong together as members of the same lexical field,... but a text is held together by other cohesive means".

Both cohesion and coherence contextualise a text and or create the discourse. Greenwood's and Wingard's definitions arise from practical teaching perspective.

Wingard, P.

For Wingard (1981:161):-

"A text means any continuous example of language in use; that is language employed for some purpose".

He adds that:-

"Cohesive features of language are those which are characteristics of texts spoken or written, and would not be present in a series of disconnected sentences or clauses".

and "Cohesions consists in the relations of meaning which exist between different parts of a text. It is expressed partly through grammatical features and partly through features of the vocabulary used, as well as in other features such as punctuation and intonation."

Punctuation in written texts and intonation in spoken ones.

For both Wingard and Greenwood, we can say that a discourse is a stretch of language in use, for some purpose, whose parts are joined together by more than one tie. i.e.

(a) cohesion ties,

(b) coherence ties,

and (c) common or shared knowledge ties.

They prefer language in use for teaching and learning purposes.

Abbot and Wingard

Abbot and Wingard (1981:82) emphasise this:-

"...some people learn English for practical purposes that are relatively easy to specify. In such cases, the use of these purposes or functions as a basis for teaching seems to have a great advantage over the use of paradigms or patterns as usually laid out in materials for 'general-purpose English', in that it caters directly for the motivation of the learner".

The knowledge of the functions in the discourse of the discipline aimed at increases motivation. So does the knowledge of the realisation of such functions in grammatical forms if brought out to light. That is what Abbot and Wingard want to say. Their very wide practical experience tells them that the knowledge of cohesion and cohesive devices in a discourse contributes a lot to purposeful learning; especially in ESP courses.

Stern, H.H.

Stern, H.H. wrote about discourse analysis. He agrees with Hoey that Z.Harris was the first to deal with discourse analysis. Harris (1952:357) quoted in Stern (1983:133) wrote:-

"Language does not occur in stray words or sentences, but in connected discourse".

What Harris is saying is that discourse means 'a stretch of connected language beyond the sentence'. In a similar view to that of Hymes, Stern (1983:130) writes:-

"In the course of the twentieth century the scientific emphasis has shifted from the study of speech sounds (phonetic and phonology) to grammar (morphology and

syntax) then to meaning (Semantics) and the study of texts (discourse analysis). Linguists have of course always been aware of the fact that in language all aspects are involved".

He later notes the stages of development of discourse analysis and its studies. (1983:133):-

"Recent work in Syntax and Semantics has made it clear that linguistic investigation can no longer treat the sentence as the ultimate unit.... Since about 1970 Linguistics has moved towards the study of aspects of language beyond the sentence through discourse analysis".

Here again Stern states it what he believes should happen..

The treatment of aspects of language through discourse and discourse analysis, not through separate sentences. It is the researcher's belief that studies in discourse analysis do contribute to enlightening teachers, students and course designers concerning the nature of the discourse of interest to them. They also have impact on course designers as to course content and methodology.

Stubbs, M.

Stubbs writes about discourse. He starts by trying to give a definition (1983:1) of discourse and discourse analysis:-

"I will use it - discourse analysis - in this book to refer to the linguistic analysis of naturally occurring connected spoken or written discourse... it refers to attempts to study the organisation of language above the sentence or above the clause, and therefore to study longer linguistic units, such

as conversational exchanges and written texts".

Stubbs' definition of discourse is 'a connected spoken or written piece of naturally occurring unit of language in use.' It is mostly the written texts that we are after in this Chapter, and as a corollary we are going to discuss classroom interaction and activities in the next chapter. Conversational interaction is as rich and illuminating as the written texts we are aiming at.

According to Stubbs (1983:9) text and discourse do not vary much. He is like others in believing that texts and discourses change places. Yet he tries to clarify the delicate points that he thinks make them differ. He is of the view that a text is usually a written form of cohesive and coherent language unit which may be short or long according to context. As seen by him discourse is usually spoken and may be longer than a text. But when it comes to the term-discourse analysis -, he prefers its embracing both text and discourse; which is another way of saying they are the same or similar. Stubbs goes on enumerating the basic elements which may include (1983:47):

1. Sender
2. Receiver
3. Message form
4. Channel (e.g. speech versus writing)
5. Code (e.g.dialect,language or jargon)
6. Topic
7. Setting or situation.

The researcher's view is identical to this of Stubbs as regards the basic elements occurring in an oral or written interaction.

Hoey, M.

Hoey (1983:15) writes:

"A discourse is any stretch of spoken or written language that is felt as complete in itself".

As usual we have the ideas of 'spoken' or 'written' and that of a 'whole' which have been very much in use. We are underlining this spoken or written because some i.e. Stubbs, have tended to use spoken with discourse and written with text. Others according to Hoey have interchangeably used texts for discourses and vice versa yet, it is very difficult to define 'complete' which Stubbs added to the definition since completeness is usually relatively considered by different people.

Hoey (1983:33) refers to macrostructures or texts:-

"The emphasis laid by Van Dijk and Kintsch (1978) on the active psychological process of comprehending and recalling the macrostructures of discourses (or as they would prefer texts) is that adopted here (though no assumptions are made about the correctness or otherwise of their viewpoint). Instead the emphasis is laid on the ways in which the surface of the discourse (not necessarily to be contrasted with hidden depths) contains sufficient clues for the reader listener to perceive accurately the discourse's organisation".

Concerning the above quotation, the researcher agrees with Hoey and Van Dijk about the macrostructures of discourses or texts. Though this may only refer to surface issues. The researcher believes the macrostructures serve as introductory steps to defining discourse. Once the process is started, the reader-learner - can carry on with the process of analysis which is multilayered. The reader-learner will, through his own discretion, find relations; functional, semantic, sociocultural and cohesive which will enable him to analyse and eventually be able to understand the discourse. 'It is not unusual', according to Hoey 'to find multiple relations between parts of a discourse'. He goes on to say that (1983:61):-

"Each sentence in a complete discourse has a function in the discourse as a whole, either in itself or as a part of a larger unit'.

So to Hoey discourse consists of units which form a complete whole. This in a way reflects the previous quotation from Hoey.

Widdowson

According to Widdowson, one of the most important exponents of ESP-previousuly so -(1979:98-99) 'Text analysis is the study of sentences in combination'. For him 'Text Analysis' and 'Discourse Analysis' are different ways of looking at language in use. One may see it as a text..., a collection of formal objects. The other way sees it as discourse. It is worth mentioning Halliday's view of the text as 'a whole', 'a unified whole', and 'a semantic unit', put together by the cohesion or

cohesive markers and devices. Those that tie the text together include: reference, substitution, ellipsis, conjunction, lexical items, parallel structures, punctuation marks and information distribution. Widdowson reiterates the 'discourse' (1979:248) and is of the view that: 'Speech acts or functions are the components of discourse'. He quotes Winter (1977:6) as regards the relations in a text (1983:77) and writes that the relation '...is seen as an extension of the systemic model of Halliday'. They are seen by Winter as 'matching relations', and 'logical sequence relations'. Widdowson adopts the nomenclature 'schemata' as the unifying factor of sentences into texts and asserts that the aim of teaching should be to develop the 'capacity' or as Widdowson (1983:106) writes:-

"The ability to realise particular meanings, solve particular problems, by relating them to schematic formulae stored as knowledge,....".

Commenting on Ewer's and Boy's view of 1981. His opinion is that what they aim at are functions and communicative operations in discourse. In fact what Widdowson (1984:100) gives as a definition of discourse is:-

"Discourse is a communicative process by means of interaction.....its linguistic product is a text.

which includes the words; 'communicative', 'process', 'interaction and linguistic'.

If it is permissible to put it so, discourse will have a communicative linguistic operation as its core. Even in another version of Widdowson's definition (1984:101) the words 'language' and 'process' are there. He adds to these words like 'negotiate' and 'conveyance' of

information and intention".

Such words refer to the need for language for negotiating, interacting, and the conveyance of information and intention. 'Discourse is the process whereby language users negotiate a reciprocity of perspectives for the conveyance of information and intention'. This definition refers to the form, the content and also the rhetorical function of discourse. It refers to the information conveyed in bits and that obtained as a whole. We can say that it refers to information blocks as parts and the function of the discourse as a whole.

In order for the language teacher to understand parts and wholes and teach them as Widdowson says (1984:98):-

"Clearly the language learner has to acquire the ability to act upon his knowledge to exploit it to achieve communicative objectives".

Widdowson aims at understanding discourses and the procedures used so as to help describe activities which create favourable conditions for acquisition and the necessary ability for language use.

Flowerdew J.

Flowerdew, J.(1985:1) touches upon discourse. At first he writes:-

"The term 'discourse' here is taken to mean both a - the functional value of utterances, what Halliday (1976) refers to as 'meaning potential', and b - the combination of utterances in the creation of language events".

Trying to build up his thoughts Flowerdew writes that a function or a speech act is taken to mean a unit of language which represents an action we perform when speaking, using language or putting language to its use. He quotes (1985:3) Labov (1972:299) and the latter's study of discourse. Labov had done so with a view to defining rules of use as one of the major aims of discourse analysis. Labov was mostly emphasising sociolinguistic concerns. But to Flowerdew:

"The fundamental problem of discourse analysis is to show how one utterance follows another in a rational, rule-governed manner - in other words how we understand coherent discourse".

In using 'utterance' Flowerdew is using it in preference to clause or sentence and because he is aiming at spoken discourse. Then we come to 'rational, rule-governed....' which do not go together with Flowerdew's quoted opinion of discourse:-

"it is claimed that because the structure of the discourse is not predictable in the same way as the sentence, clause or group is, and the learner therefore needs practice in building up his own sequences".

To put it in another form, Flowerdew wants us to understand the "utterance", know how it is used to build up 'coherent discourse' in one way or the other and finally to start to 'be creative' as users of discourse. One cannot be sure of what comes or should be included in discourse; that is if statement B should follow statement A and that statement C should follow after both A and B have consecutively preceded. It may be so in science.

Anwar M.S.

Anwar, M.S. (1985:1) gives the following definition:-

"A discourse may be one sentence, a sequence of sentences, a paragraph, a chapter, an article or even a book".

For him it is a 'text' that should have 'unity, coherence and progression'. Anwar again lays emphasis on the outer layers acquired by the text; not its mere dependence on syntactic structures. This can compare positively with Widdowson's view previously mentioned. Since texts or discourses are meant for communication and communication, specially if not face-to-face one, can have different devices assisting it i.e. Austin (1962) Searle (1969) in their speech act theories, Grice (1975) in his 'Co-operative Principle'. Hymes (1972), Labov (1972) and Leech (1980) pushed in Pragmatics as it is very helpful in the purposefulness of communication. It is not only the speaker that decides the force of the communicative act or event, but also the hearer and the illocutionary force of the communicative tool in its underlying structure. Grice like Leech separates the functional explanation from the grammatical realisation of, say, a sentence. Linguists feel it might be helpful to solve some of the form-function problems by resorting to philosophical discussions of speaker intent (Hatch, Long 1980:3).

In our view discourse is a stretch of spoken or written language in use. This stretch, out of necessity, should be formally realised in utterances or sentences that convey certain rhetorical functions. Each discursal unit or communicative event may be completely different

from the other to the extent that makes it natural not to be able to predict what will follow that which has preceded, most certainly in some cases of oral interaction. It should form a whole that is interwoven together through intrasentential and intersentential cohesive devices. It should have progression though the researcher does not necessarily stipulate the stages and the number of participants that lead to some fixed sort of discourse realisation. For coherence purposes a discourse should be purposeful and communicate a message proposed or intended by the interlocuter. Discourse could also have its bases in many disciplines.

In fact the researcher will consider many elements when dealing with written text or discourse. One of these variables is the functions, both the macrofunctions and the microfunctions, conveyed by the text according to Trimble and Halliday.

The other is the kind of discourse there is in the text which some call genre but it is the kind of register according to Swales.

A third is the semantic side, namely the lexical signalling in the text according to Hoey.

A fourth is the realisation of the functions mentioned above and in what structural forms they are put. Whether one form is or can be limited to one function or not, we will see. If they do not, then this supports Halliday's opinion that texts may serve different functions.

Then we will move to the information content of the text in the fifth. How the information is presented and arranged in the text as it is. Is it according to 'topic'? Is it according to concepts? and/or processes? How are these realised? Are they, for example, arranged in information blocks, in units, in paragraphs or what else? That is how and why they are presented according to one system or the other.

Can we for example, predict that sentences B and C will follow sentence A and that sentence D will form an end to the information block? Will that be according to function or sequence of presentation which as a whole may be called a unit? What will the text look like, a linear one or a nonlinear one or a mixture of both? Does it as a corollary always come in the same form or does it change? Does it contain the same information or not if written by different writers? Then what about the mode of presentation. If it is tied together through cohesive ties, does it ensue that it should be coherent also? This means that we are going to tackle the communicative, functional, linguistic, paralinguistic, metalinguistic, stylistic and sociolinguistic elements in the texts that we will analyse.

We suggest the adoption of these particular criteria to be put to use when we analyse the two computer science chapters we had selected, nearly at the end of this chapter in Section 5.7. Now we move the next section 5.3 about the historical development of discourse analysis.

5.3 Historical Development of Discourse Analysis

Harris, Z.

The term discourse analysis was first introduced in 1952 by Zellig Harris. He attempted to modify the techniques of distributional analysis of the post-Bloomfieldians to suit the analysis of discourse. He noted that one can make predictions about what will follow any particular sentence in a discourse and showed awareness of the cultural and stylistic importance of discourse work.

Pike

Pike (1959) quoted in Hoey (1983:189) showed a similar awareness to that of Harris and made a number of challenging claims about the organisation of discourse in the course of his presentation of a model of language designed also for the organisation of human behaviour. Harris's analyses were formal concentrating on linguistic elements of phonemes, morphemes and grammatical classes.

The development of discourse analysis has been witnessing various approaches as early as the Hellenistic era. The debates of Plato stand as an excellent example.

Austin and Searle

Austin (1962) and Searle (1969) consider speech acts from the philosophical point of view, meanwhile others like Labov (1972) Hymes and Gumperz (1972) prefer to use speech event to speech act.

Gumperz and Hymes

They dealt with events from the socio-linguistic point of view to suit their own purposes in ethnomethodological studies. Their studies were very useful for discourse and also for the disciplines they dealt with.

Grice

Grice thinks that if the discourse is oral, it refers to a conversation which then should be some form of co-operative venture. By this Grice wants to say that it includes or needs efforts of more than one person or the participation of many to occur like the addresser and the addressee if they were alone. In so doing one has to resort to what Grimes (1975) calls 'the Co-operative Principle'. This principle asks the interactant to be

- (a) brief,
- (b) informative,
- (c) truthful, and
- (d) relevant and clear.

By applying these four maxims, Grimes asserts, we understand discourse even if the sentences are not cohesive or directly related. Moreover we can understand sentences which seem unrelated in conversation as related through implicature.

In fact many philosophers and linguists have been trying to include more than the syntactic structures, when attempting to attach meanings to utterances, clauses, sentences, texts or even discourses. This leads to including Pragmatics which includes syntactic form, propositional form and value in order to serve the

purposefulness of the text or that of the discourse.

Cook

Cook tried to relate grammatical and semantic roles in textual analysis. He (1978) used a revised form of Fillmore's Case Grammar, applied it to Hemingway's 'The Old Man and the Sea' and found out the multilayered nature of the language caused by stylistic variation.

Candlin

Candlin (1974), (1975) (1976) and (1980) analysed a corpus of doctor-patient discourse. Another corpus was that of doctors specially foreign doctors in casualty. Those were carried out for pedagogical purposes. Two subjects, a teacher¹ of English and a naturalised doctor² have assured the researcher of the success of these courses and subjects being taught after analyses had been carried out on functional bases. Another indicator of success is that examinations devised and administered have been adopted by the UK authorities and similar bodies since then. Though the discourse process - communication - had been mostly oral, it had delineated limits which made it possible to benefit from. Partly they were routines, but not so in all cases. They served as parts and wholes; the former as information blocks and the latter as a result of communication achieved when the interactional process comes to an end.

1. Mr.Hajir, Y. of the KBI, formerly a graduate student at Lancaster University in the U.K.

2. Dr.Alsaad,H. Formerly of Coventry & Warwickshire Hospital in the U.K. Personal Communication.

Shuy

Shuy (1981:36) recognised four types of topics that occur in a discourse:

- (a) substantive,
- (b) corollary,
- (c) transitional, and
- (d) ostensible topics

Yet what we are interested in are the developments that have been taking place during the second half of the twentieth century. Harris's distributional analysis was later followed by various approaches.

Kuno

An American linguist i.e. Kuno (1983) showed the deletion of optional constituents in a sentence followed a certain principle - from less important to more important information. In his 'Principle of Discourse Deletion' he called this 'The Pecking Order of Deletion Principle'.

Tannen

Tannen, D. of Georgetown University in the USA has been doing research in the field of discourse analysis. Her approach is based on both the organisational and informational content of discourse.

French Scholars

In France text analyses were carried out by Prop in 1958. Then many codes were put into effect such as aesthetic, sociological,

astronomical and cosmographic codes to show that the principles of language are similar to the principles of these codes.

The semiological system came to be used. It led to the creative function of the text when it becomes larger. According to it there are many levels of the text; not a merely linguistic one. So when talking about the syntactic aspect of a text, French Linguists like Barthes, Derrida, Sollers, Ducrot and many others, mean the relationship among textual units, sentences or groups of sentences. This is based on:-

- (a) propositional analysis - subject and predicate;
- (b) semantic aspect - overall semantic content; or
- (c) the aesthetic aspect.

It could well be said that this is a pragmatic analysis which may give significance to many levels, contexts such as

- (a) philosophical,
- (b) psychological,
- (c) biological-psychological,
- (d) biological-logical, and
- (e) the aesthetic level.

The semiological seems to have advantages over the others. Its significance lies in the union that binds its content and value.

In the preceding part about the historical development of discourse and/or text analysis, we did not mention every one in the field. A brief outline was given about the subject. Repetition was avoided in the case of the studies of Labov, Gumperz, Hymes

and Halliday. Either they were mentioned before or will be mentioned later if it becomes necessary to do so. Some were not published like Winter. E. which makes access to it very difficult. Now we proceed to the next section relating to Approaches to Text Analysis.

5.4 Approaches to Analysis

Very serious efforts in the analysis of discourses of different disciplines have been exerted in the UK. Apart from those studies of Sinclair et al (1975), Wingard (1976), Candlin (1975-1980), Winter (1976-77), Hoey (1978-1983), Beedham and Bloor (1980), Stubbs (1978-1983) etc. Davies, F and Greene T (1984) have performed an excellent job in their 'Reading for Learning in the Sciences'.

The last two took a fact-finding mission concerning reading. They investigated the incidence, quality, nature and different contexts of reading. They (1984:43) believe that:

"The key to success in learning from any text in science is the choice of the right method to get the most out of it. This involves an understanding of the ways in which texts are structured".

They add :

"We propose that a first step is to concentrate on the content and structure of texts used in science, rather than on features like terminology. In effect we are saying that if we take care of content and structure, terminology will look after itself".

(Op Cit)

They, in fact, discuss all aspects of texts, their overall structures and functions. The division of a text into structural parts and information blocks has been tackled by them, so as to help learners read, understand and reproduce texts if wanted to do so. Practical communicative activities have been devised in order for learners to achieve maximum benefit. Davies and Greene (1984:78) declare:-

"Our long term aim is to help pupils to acquire the specific frames - the information structures - required for interpreting and writing texts in science".

They aim at pupils while the researcher's aim is adults. The difference of age could be compromised for English is to the adults a foreign language. The former two aim at eleven-year olds and a little above. The difference is that of seven years which is nearly the age of a first grader in our part of the world.

Davies and Greene also aim at texts and or discourses for reading purposes. We can claim after all that it had been mentioned that our aims are similar if not the same, as reading for learning in science is a part of our broadly mentioned purpose. It forms the first yet foremost stage in the learning process especially in such areas as computer science where most of the communicative events are carried out in English. That is why the Reading for Learning in the Sciences results partly apply to our situation in its first stage i.e. when carrying out the theoretical part in an ESP field of specialisation.

Upon finishing their project in Science, Maths and Social Studies, Davies and Greene have come to the conclusion that:-

"The broad categories have been identified: those dealing with activities, phenomena and ideas. Within these categories, seven types of text presenting distinct information structures have been proposed: instruction, classification, structure, mechanism, process, concept principle, hypothesis theory".

Our aim is not to let teachers start analysing texts in classrooms, so as to prove such categories, but rather let them know methods and examples. With this information, teachers will surely be well-conversed with text types and structures. Course designers get more benefit through including such text types in their designs of ESP courses. Thus they facilitate things for both teachers and learners who aim at mutual understanding and, in the long run, success. This includes both linear and non-linear texts. Linear texts are those stretches which are carried out in the usual writing form line after line meanwhile non-linear ones are those that are not similar to the former category and are presented in the forms of charts and diagrams etc. The main focus in linear texts is usually on functions such as defining, describing, explaining, exemplifying, sequencing, comparing, hypothesising, concluding etc. Non-linear texts do not show such functions. A point that should always be kept in mind is that a text may consist of both linear and non-linear elements of a text. There may be places where interest to have one or the other form of a text is preferred by the author, designer or scientist. When we have more than one frame in some texts, we usually call them

multi-frame texts. As Davies and Greene (1984:122) put it:-

"Nonetheless, we cannot recommend a system for classifying texts without making reference to examples which are not easily identifiable as being of a particular type".

They also add: "to expect complex texts to yield to simple analysis would be mistaken". (Op.Cit).

The development of such an approach of text or discourse analysis is the responsibility of all those interested in the field. It will eventually allow a greater potential for learners through supplying them with examples to help develop discourse understanding.

In fact approaches to text analysis differed. While Widdowson asked the learner to have his interpretative procedures, both Hutchinson and Waters did not support the idea of even introducing subject-specific materials. For them materials should concentrate on the language. It is worthwhile mentioning some approaches to text or discourse analysis for ESP courses. One should bear in mind that there may not be so much differences between or among them since their aim is to benefit ESP learners.

(a) The methodology plus word and structure count of Barber and Herbert.

(b) The identification of notions-concepts which are central to science and technology and to specific subject areas of Bates and Dudley-Evans of the Nucleus Series.

- (c) The Authentic Resource Materials approach of Phillips and Shettlesworth. They wanted ESP courses to be entirely on based on target texts. They are wholeheartedly for genuine ESP texts.
- (d) The approach of the development of relevant and appropriate interpretative procedures in the learner to the target subject and setting of Allen and Widdowson of the Focus Series. Widdowson asserts this rather than covering schematic elements of scientific English.
- (e) The development of the learners' competence to enable him to understand ESP texts or discourse approach of Hutchinson, T. and Waters, A. taking into consideration learners being originally subject specialists who do not need to know about content. They do not support texts rehearsal.
- (f) The rhetorical analysis based on target texts approach of Lackstrom, Selinker and Trimble. This assumes the commonness of organisational features in a discipline or a type of texts.
- (g) The count or frequency in lexical and linguistic content approach of Ewer and Lattore.
- (h) The approach which allows the exploitation of more than one element. We mean that of Tarone et al.
- (i) Swales's approach of analysing the genre which leads to register analysis or the analysis of

a type of English used by comrades of the same trade. Swales sees this sort of analysis as a way of pushing the status of ESP forward

He aims at communication and communication is developed through interaction in socio-cultural meetings in purposeful communication.

5.5 Computer Science Text Analysis

Beedham, C. and Bloor, M. (1980) formerly of the Language Studies Unit - LSU - of Aston University in Birmingham in the UK felt the need of foreign or overseas pre-M.Sc students intending to study Computer Science for help. Therefore they started an analysis of three Computer Science textbooks¹ used in Aston. Their means was text analysis and their aim was Pedagogics.

Their objectives were to identify the communicative functions of the language used in these books, then to use that information for pedagogical purposes. They based their analysis on the fact that they wanted students not to know what language is but what it does. Language in context and not in separate items was their target. For that purpose, they spent one year studying and analysing the textbooks for identifying the communicative functions used by the authors and how they were realised in linguistic terms or as Beedham and Bloor (1980:1) put it:-

1. The Books Beedham and Bloor chose are: Elson 1973, Page & Wilson 1973, and Shave (1975).

"....to examine the relationship between communicative function and lexico-grammatical form: to try to uncover the formal realisation of communicative functions in Language".

The result was that they came out with the following thirteen communicative functions:

1. Algorithms, description of, e.g. 1 below:

- (1) Search to the right until we find the first stack $j(i)$ which is not using all its storage space, i.e. $Top(j) < Bottom(j + 1)$.

2. Commentary on programs/description of languages, e.g. 2 below:

- (2) The % prefixed to a statement indicates that the action specified by the statement is to be carried out at the time it is encountered by the macro-processor.

3. Comparison: advantages/disadvantages, e.g. 3 below:

- (3) The main disadvantage of this method is that it often produces clustering of the occupied locations. Of the methods described for handling collisions, this in practice is the least effective in terms of the average number of probes necessary to retrieve an item.

4. History, e.g. 4 below:

- (4) Traditionally, computer languages have provided the means for linking related items within a set of information, but have placed on the user the responsibility for specifying what relationships

actually exist.

5. Definitions/naming, e.g. 5 below:

- (5) A queue is a linear list in which additions are made only at one end of the list (the 'rear') and deletions only at the other end (the 'front'.)

6. Analogies, e.g. 6 below:

- (6) To link a computer directly to such slow mechanical media would be like using a very fast car when delivering letters to all the houses in a street.

7. Exemplifications/application, e.g. 7 below:

- (7) Searching auxiliary storage devices is one application area in which these types of scanning algorithms are useful.

8. Introduction of problem, e.g. 8 below:

- (8) Clearly this information must be represented in a manner which a computer system can accept, but before deciding on a method of representation a more fundamental question is the content of the information - just what facts about the problem does the information convey?

9. Calculation, mathematical, e.g. 9 below:

- (9) Taking $2^{k-1}n - 2^k - 2$ we have to subtract from L the value $(2^k - 1 - n)k$ and thus (7.3) becomes $L = 1 - 2^k + k + kn$.

10. Recap, e.g. 10 below

- (10) In short, the PL/1 picture with regard to overlay defining is a complicated one, fraught with rules and restrictions which on the language

surface appear quite arbitrary and unmotivated.

11. Metastatements, e.g. 11 below:

(11) In a later section we consider the various operations on linear lists when the nodes are not stored sequentially.

12. Bibliographical references, e.g. 12 below:

(12) Basis theory is covered in Knuth (1) and Riordan (10).

13. Exercises, e.g. 13 below:

(13) Show how a tree data structure can be represented by means of chained files.

Beedham and Bloor wanted the students/learners to benefit as much as possible by being guided through communicative teaching which takes into consideration the communicative aspects of their target texts leading to target performance. They also wanted to establish documented evidence for their doing so in this field of ESP. Their aim was to help illuminate the communicative aspect of this register or variety of the English Language.

The researcher believes they have succeeded to some extent, in their mission for three main reasons:

- (a) They were able to identify thirteen communicative functions used in the Computer Science register so as to be utilised in teaching.
- (b) They confessed the existence of the multilayered basis of language. This means that more than one function could be understood through one clause or sentence. For this reason they intuitively selected

what they believed to be the most prominent function and concentrated on both explicit and implicit markers of such functions.

(c) They, as far as we know, were the first to do this analysis of Computer Science textbooks (1980).

Beedham and Bloor also recommended (1980:24):-

"...the view that there is a need for increased activity in the teaching of vocabulary, particularly on courses for academic purposes".

According to them:-

"Key words in the computer science corpus are clearly associated with certain communicative functions and thus take on a communicative significance the misunderstanding of which can lead to serious misreadings". (Op Cit)

Beedham and Bloor (1980:27-28) concluded:-

"Since no direct, inherent connection was established between grammatical form and communicative function and since any a given grammatical form which was examined tended to appear in all communicative functions, quite serious doubts are raised as the variability of language instruction on a syllabus which attempts to map particular grammatical items to communicative functions".

The case is indeed as they both assert, yet the researcher is for more text analysis to get the common linguistic grounds and the most prominent language functions realised in Computer Science jobs. We suggest that analysis would give a better

output if it were a co-operative operation between both a linguist and a computer science specialist.

Adopting as their final decision was this penultimate statement:-

"Courses which attempt to teach English from a functional viewpoint and do so by the close and consistent association of a particular grammatical form with a particular function present an unrealistic picture of usage". (Op Cit)

The researcher agrees with them concerning this point but adds that this, if done as one step in the teaching-learning process will be a very helpful classroom strategy, which may be developed throughout the student's academic life.

The researcher would like to refer to the issues of the needs analysis he supports and mention in this respect that Beedham and Bloor took over the responsibility as teachers of English whose feel in the classroom initiated them to do so without taking into consideration the triumvirate of viewpoints he adopts in this research. There is also no reference to the social or socio-cultural aspect of the communication needs of the students. The researcher believes that teachers' preconceptions or feel in the classroom should not be the only causes for needs or text analysis.

The researcher already knows that Skeham, P. and Johns of Birmingham University are interested in computers besides many

others all over the world but what they are interested in is the utilisation of computers for teaching other subjects or in Computer-Aided Learning - CAL. In fact what Skeham wrote about was the use of computers for ESP teachers. He carried out a survey on:-

- (a) Sub-technical vocabulary which he thinks is common to all disciplines.
- (b) Specialist vocabulary which is specific to a certain discipline.

Indeed computers are very useful for the execution of such surveys and researches. It is electronic data processing, the utilisation of the speed of light or the information technology revolution.

5.6. Evaluation of 'English for Computer Science'

This book is co-authored by Norma P. Mullen and P. Charles Brown. It was published by Oxford University Press - OUP in 1983. Oxford, England but was printed in Hong Kong.

5.6.1 Layout of the Book

The book consists of 239 pages divided, and usual in any book. Under its cover we see title and publisher page, copyright page, acknowledgements page, two-page contents, three-page introduction about the book, two hundred and seventeen pages which form the bulk of the book, a nine page glossary and three-page advertisements of OUP recent ESP publications. It is also accompanied by a teacher's book, which is an advantage.

'English for Computer Science' book consists of three parts comprising eight sections. The first part is about the computer as a machine. It comprises three sections entitled Introduction, Description and Kinds of Computers.

The second part is about computer components. It also comprises the Processor, Memory and Input and Output devices; these mean hardware.

The third part is data processing and comprises two sections entitled 'Programming' and Computer-related Topics, which may be called Software.

The researcher will evaluate the book relating the evaluation to two considerations, the book as a computer science book and its suitability for KBI Computer Science students. In this respect issues concerning objectives relating to:-

- (i) learners,
- (ii) content, and
- (iii) methodology

will be taken into account.

5.6.2 Objectives of the Book

The objectives laid down by the authors mention that they aim at:-

- (i) Learners and their Needs

The authors wrote that (1983:8)

- (a) "English for Computer Science has been written for people who are studying computer science or related subjects in

universities, colleges and technical schools and also for in-company training programs where computer personnel need to improve their understanding of English".

(b) The book is also, according to them directed towards

"....individuals who want to make use of computers either privately or for their careers".

Points (a) and (b) above show that the book is meant for a general or broad type of students/learners which is not a suitable type for students at KBI. They also show that it may be used as a self-study course. This type of course does not suit KBI students simply because they have not yet acquired the ability to cope with the content by themselves. The content relating the grammatical, the lexical and the functional parts of the content exercises, we believe, is demanding.

It is also arguable that it does not serve the needs of KBI students, as it did not take into account the opinions of the students, their teachers and their potential employers. It also did not take into account, relevant elements relating to learners like background elements and target responsibilities.

(ii) Content

The content of 'English for Computer Science' is varied, and relates as a whole to computer science.

It starts by introducing computer, goes on through the computer itself and ends with computer-related topics. Yet it is lacking liveware wise. There is not much about computer personnel. The content is interesting and easy flowing as well. It is supplied with photographs but it is lacking in real excerpts from computer output. Comparing it with 'Information Processing' by Fohl from which we will analyse a text, we find that it is very much lacking in questions asking for productive output. It demonstrates only four computer generations while we are having the sixth in use. It also gives a few computer languages, not the majority. It does not contain enough structural exercises so as to refresh the learner's repertoire of grammar rules -that is the minimum necessary and aimed at for KBI students or other learners.

The contents may be suitable for our students if the book were to be taken for beginners but it is too long to be covered in one term, taking into account that all the book should be covered.

(iii) Methodology

The authors adopt the functional/communicative approach. This is clear in their foci marked A through N. Examples of these are (c) Organising information, (f) Making comparisons, (h) Giving examples, (k) Classifying, (l) Contrasting, (n) Making predictions etc.

The authors include structural foci as well but this last foci is not enough to meet students' of computer science needs. The authors (1983:9) mention:-

"(The) exercises fall into two categories; those that concentrate on form, such as the vocabulary and word formation exercises and those that concentrate on communication, such as the comprehension exercises on the passage - the latter being of utmost importance"

The authors assert rules of use but do not do that with rules of grammar. The researcher supports communicative methodology but also believes that teaching students the use of language and the rules of grammar as well in relevant and suitable context gives them confidence and promotes their interest. The vocabulary side was only dealt with which means that students may acquire fluency but not accuracy whereas the aim should be both. The researcher feels that, for example, conditional sentences and passivisation have not been drilled though they form an important and integral part of any computer program.

5.6.3 General Evaluation of the Book

The researcher relates the unsuitability of the book to the lack of text analysis on the part of the authors. So this book cannot be adopted for KBI students due to its not being the optimal one to fulfil KBI researched students' need, appropriate computer science content and relatively balanced fluency accuracy strategies. The authors (1983:10) add:

"This approach encourages genuine communication among the students or between the students and the teacher, making the classroom student-centred

rather than teacher-centred".

The researcher would like the approach to be learning-centred rather than giving the central role for either the teacher or the students. We want roles to be integrative for an optimal output.

Regarding skills, the authors of 'English for Computer Science' announce that the book is a reading course which aims to develop many reading skills. This also is not the proper method. The researcher prefers such course to integratively develop the four skills, the receptive and the productive integratively. The focus of interest on the reading skills on page 10 of the book hardly tackles the writing skill so as to develop it.

The researcher finds the book 'English for Computer Science', as a whole an interesting one, with computer-related content, developing fairly communicative methodology, and reading-biased regarding skills. It also forms a new addition to the ESP limited repertoire though the researcher would not adopt it for KBI Computer scientists for the reasons previously mentioned, for its being lacking in the socio-cultural or social aspects of life, and for inadequate application of communication skills.

5.7 KBI Computer Texts Analysis: The method of selection and the books.

The method followed, in order to get the texts, started in the students' and teachers' questionnaires - interviews - where

a question asking the respondents or interviewees to specify two to four textbooks used by students or recommended for them for learning purposes. After inputting the results, two chapters from two textbooks have been selected. Each chapter is the second in the book it was taken from. One book "Computer Appreciation" by T.F.Fry - Newness - Butterworths, 1975 is an English Book and is printed in the United Kingdom. The other is "Information Processing" by Marilyn Bohl - SRA 1983 - 1984 Fourth Edition. This book is American and is printed in the USA.

For the sake of uniformity, Chapter Two from both books was chosen on the basis that they dealt with nearly one topic - that of the basic facilities of a computer system. The two authors of the books present the topic with slight changes in both Chapters. The field, apparently, of these books is Computer Science, but the functional tenor is Pedagogics. Thus the scientific discourse - register - or variety of the English Language that will be analysed could well be described as Pedagogical English for Computer Science.

What makes the two books from which the two chapters were taken representative of the corpus of Computer Science textbooks is that they had been selected by both teachers and students of the Computer Science Department of KBI. As students who are supposed to study the courses that would be designed are Computer Science students, then we are justified in calling the output as English for Computer Science students which is a part of the broader English for Specific Purposes.

5.7.1 Texts' Representation of Computer Science Texts

How far these analysed texts represent the whole corpus of Computer Science texts will remain an unresolved problem. However, since the texts selected and specified are parts of the recommended books by the Computer Science Department of KBI, they would surely give valuable indications of the discourse being dealt with. No doubt the time at hand for the researcher and the limited nature of the textbooks to be referred to have contributed to confining the researcher's field. The results that would accrue would be accurate and commensurate with English for Computer Science specialisation.

The texts were carefully read and the researcher attempted to intuitively identify the communicative functions as they appeared.

5.7.2 Objectives of this KBI Text Analysis

The objectives of this section of KBI text analysis of computer materials are those mentioned at the beginning of this Chapter Five.- except where they do not relate in the points mentioned before and where they do in (f) section 5.1 which reads:-

"To establish a documented systematic basis of data for the inclusion of text analysis in the process of needs analysis as a prerequisite **issue** in course design for KBI computer scientists in particular and for KBI students of other specialisations in general. The results will become suggested specific content for the inclusion of functional and linguistic content of ESP courses."

The same case applies to (g) which was stated before in section 5.1.

5.7.2.1 The Functions Problem

Hymes (1980:50) wrote:-

"...the problem of overcoming the function of language is first of all a problem of discovering the functions language does have".

This is what the researcher is going to do in this section.

5.7.2.2 Hymes also noted some studies which are about 'units of language', their relationships' and asked for experimental studies about these units and relationships. For the purpose of analysis Hymes adds (Op Cit):-

"A certain command of Linguistics is required to deal with units of language, but where relationships among the units is in question in terms of alternative models, experimental study need not wait upon the linguist".

But Hymes does not think so. He (1980:39) asks us to investigate the functions of language and not take them for granted:-

"Linguists have mainly taken the functions of language for granted, but it is necessary to investigate them - such investigation is indeed going on, but mostly in Linguistics".

The researcher believes Hymes was right when he wrote about the topic though many changes and developments have been taking place since then.

The problem of difficulty concerning functions was gradually eased by Wilkins (1972:14-23) who wrote that there were eight categories of functions. For Van EK (1980) they were six functions-while Finocchiaro (1983) reduces them to five categories - eleven topics. These include the personal, the interpersonal, the directive, the referential and the imaginative categories. They usually refer to what we do, usually do or can do with language in speech acts or speech events.

5.7.3 Text Analysis

The first book which was recommended for computer science students by their teachers is 'Computer Appreciation' by T.F.Fry 1977 Newnes-Butterworths. It consists of fourteen chapters or 237 pages. It also contains more than 60 figures explaining various computer issues, where necessary. It is printed in black and white. In the researcher's view it is easy to handle. It has been described as '...an excellent book' in the Computer Bulletin. In the Economic and Social Review, it also has been described as '...an excellent book, written in a simple clear style and amply illustrated with applications".

The book and these comments may have initiated its being chosen for KBI.

In the analysis of the chosen text, Chapter Two, page 13-19, we based our analysis on two main issues:-

- (a) The functional approach-concept of communicative function - or why it was articulated in the way it is now; and

- (b) The grammatical realisation of the text. Of course the impact of each approach on the learning-teaching process will be referred to.

The researcher has dealt with the Chapter as a piece of communicative writing, which is organised in the way its author meant it. But for practical purposes, the researcher has dealt with it as paragraphs to suit his own purpose. To be precise the researcher adopted the following definition of the paragraph: "a stretch of sentences, in a discourse, dealing with one main idea, marked in writing by indented line at the beginning and finished in whatever form its writer sees necessary without running on into other parts of the discourse". The researcher likes to differentiate between two kinds of paragraphs. The first is the one whose definition has just been adopted. It is called a physical paragraph. The other is called a conceptual paragraph which may be described as one or more physical paragraphs, as necessary for the communicative function it is meant to have by its original writer. Yet the researcher still considers the sentence as the basic unit in written discourse.

In dealing with functions the researcher adopted what he thought the most salient function of the paragraph in perspective. The three figures included in the chapter serve as parts called non-linear texts complementing the linear ones in the discourse.

As the title of the chapter 'Basic Elements of a Computer' shows, the main topic is the computer. When we go deeper in the text, we certainly would like to shift it to 'Computer Installation'. As the main or major topic is computer, the minor or subsidiary

details are those of and about the basic elements or computer components.

Having delineated the major and minor points, we commence highlighting the communicative functions realised in the text while keeping in mind that the original author meant the text for communication and reflection as it is about a subject; it is really the output of experience in the pedagogical field. For this pedagogical purpose, the researcher has treated the text as paragraphs having functions.

5.7.3.1 The first Text: Basic Elements of a Computer*

The communicative function in the first paragraph is introducing the topic plus suggesting an approach for its treatment. The second, third, fourth and fifth paragraphs serve the communicative functions of explaining through exemplifying, metastatements, sequencing-instructing and identifying. The communicative function sequencing-instructing may as well serve the function of developing the main idea. Within this paragraph the first figure is introduced. It usually leads to quicker absorption and eventually comprehension of the discussion.

The sixth paragraph on the next page serves summarising. It summarises the four processes; inputting, storing, processing and outputting. Paragraphs two through six form one conceptual paragraph whose communicative function is Algorithm. Algorithms are sorts of instructions to carry out or execute orders. For an example see no.1 in the functions. The seventh serves logical reasoning. The eighth paragraph serves metastatements and the

ninth elaborating. The whole of paragraph ten is for defining various computer components and operations. The eleventh is referring for elaboration purposes. The twelfth serves the communicative function of recapitulating which is aided by two figures, the first on page 16 and the next on page 17. They both show basic elements of a computer and elements of a computer configuration. The thirteenth paragraph introduces basics which are peripherals and a central processor. Item describing is achieved through the rest of the chapter on pages 17, 18 and 19.

Central Processor

The beginning is with the central processor-paragraph fourteen is for defining, in fifteen the writer is giving details or describing a process. The same is done through paragraph sixteen - referring and synthesising are also there. Paragraph seventeen serves defining, criticising and describing operations.

Input

Paragraph eighteen starts with input defining and exemplifying. One salient point is the use of conditionals in this paragraph. Through paragraph nineteen elaborating is achieved.

On page 19 inputting, processing and outputting have been described as processes.

Output

In the last paragraph or number twenty the process of outputting has been explained.

A list of exercises follow the chapter.

Exercises

The questions in the exercises ask for defining, explaining, comparing, mentioning advantages/disadvantages or contrasting and exemplifying etc.

5.7.3.2 The Communicative Functions. Realised in the Text

Through the analysis of the text - see text in Appendix C1. We can say that the communicative functions that occurred are the following:

1. Algorithms and/or description of instructions or proper execution of orders in a program e.g. 1 below taken from Text 1 to be found in Appendix C1.
 1. On receipt of the requisition the clerk is required to enter in the relevant column the unit price of article, which is obtained by reference to a price list. He then multiplies the unit price by the quantity and enters the product in the £.p. column. Should there be more than one line entry on the form, he will have to add the column and enter the total at the bottom.
2. Analogies e.g. 2 below which is taken from the text in Appendix C2.
 2. Any of the common input devices can be used to do this, because instructions, like data, can be expressed in machine-readable form.
3. Commenting and describing e.g. 3 below, which is taken from Functional Unit in Text C2.
 3. An EDP (electronic data processing) system

typically consists of four types of functional units: the processor unit, secondary-storage devices, input devices, and output devices.

4. Comparing and/or contrasting e.g. 4a and 4b below taken from text C2 'Microcode'.

4a. Unlike other internal storage, the ROM (Read Only Memory) cannot be occupied or altered by regular stored-program instructions or by data.

4b. Such a computer has certain standard features plus the optional capabilities that are wanted or needed.

5. Defining and/or naming e.g. 5a and 5b below which are taken from summary of text C2 and the chapter itself.

5a. The task of writing instructions to direct the operations of a computer is called PROGRAMMING.

5b. Output is data that has been processed .

6. Introducing problems, topics etc. e.g. 6a and 6b below which are taken from text C1 and C2 respectively.

6a. Before considering in detail how the various parts of a computer work, let us try to get a picture in broad outlines of what a computer is and does.

6b. In this chapter, we look first at three basic elements of data processing; input, processing, and output.

7. Exemplifying and/or applying e.g. 7a and 7b below which are taken from text C2.

7a. For example, an output device such as a printer can display information in a form that is readily understandable to us.

- 7b. The previous meter reading may be read into the computer from a magnetic tape where it was stored the previous month. Then the calculations are carried out by the computer. The customer's bill is the output. The current meter reading is stored on another magnetic tape, to be used as the previous meter reading in the next month's billing.
8. Calculating, mathematical e.g. 8a and 8b taken from text C2.
- 8a. Let $x = (a + b + c + d + c) 15$
- 8b. Enter a set of 5 numbers Average is three.
9. Recapitulating, concluding e.g. 9a and 9b below taken from texts C1 and C2 respectively.
- 9a. Basically then, a complete computer configuration consists of a central device known as a Central Processor with a number of devices surrounding it that are used for specialised purposes. They are Input Devices for reading and transferring data and programs to the processor, Output Devices for accepting information from the processor and devices usually known as Backing Stores, for storing additional data. These devices surrounding the central processor are called peripherals.
- 9b. Programs to direct computers in processing payrolls, computing accounts receiveable, scheduling airline flights, planning highways, playing chess and so on are longer and more complicated than the one we have shown here - but the basic concepts are the same. This

is what directing the computer is all about.

10. Metastatements e.g. 10a and 10b below taken from texts C1 and C2 respectively.

10a. We start then, with data recorded on a requisition form and at the end we have an answer recorded in f.p.

10b. Now you have an idea of what a computer is and what it does. Would you like to see how simple communicating with the computer (and even directing it) really is?

11. Exercises including different activities e.g. 11a and 11b below taken from texts C1 and C2

11a. Compare a digital computer with a calculating machine and outline advantages and disadvantages of the computer.

11b. Refer to Figures 2.4 and 2.11. If you have access to a computer system, enter the program into storage as suggested.

(a) What actions are caused by the Statements on line 120 and 130?

(b) If you provide the values 20,30,45,30 and 25 as input, what information should the computer provide as output?

(c) How do you get the computer to stop?

Other communicative functional activities can be seen elsewhere in the books and so can bibliographical referring. The first chapter of Fry's book serves the latter two communicative functions.

5.7.3.3 The Second Text: The Computer as a System

The second book recommended for KBI Computer Science students is Information Processing by Marilyn Bohl, Fourth Edition 1984 SRA. It consists of seventeen chapters in 558 pages and more than 600 coloured pictures and figures explaining various computer issues. Each chapter is introduced with a synopsis giving a brief idea about the topic right from the beginning. The user is enticed to go through the chapter to discover what the life-like pictures are about, for himself. Not all pictures and figures are coloured; some are in black and white e.g. those on pages 11, 12, 13.

In our analysis of the chosen text, chapter two starting from page 36-57 we based our analysis, as in the previous text, on two approaches. These are the fulfilling of a communicative function and the existence of a consistent grammatical realisation.

The researcher has dealt with the chapter as a communicative piece of writing in the computer discourse meant for pedagogical purposes. As with the previous chapter, the researcher has considered the text in terms of paragraphs; the definition in 5.7.3 is still adopted. Numbering the paragraphs has been done on a topic basis in this chapter. We mean sections adopted by the author. The researcher, in his analysis, also adopted what he thought the most salient function of the paragraph, although some paragraphs may have shown tendencies to convey one, two or more functions.

As the title of the chapter suggests 'The Computer as a System', the basic topic is the computer. Immediately after the title are five consecutive paragraphs which serve the communicative functions of introducing, giving implications, commenting, comparing and bringing the topic to an end, or rather suggesting having a look at later chapters so as to form a link with this chapter and later chapters. Twelve photos and figures follow these paragraphs and form a colourful appetising frame for more involvement.

Once the linear text starts on page 40, we are faced with the salient points to be discussed in the chapter. These serve both introducing and summarising.

Taking communication as the ultimate aim of the author the researcher commences the analysis. Listing the basic elements and processes on page 10 is the first function to be conveyed by the salient points preceding the text.

The Computer as a System P.40

The first paragraph serves the functions of referring and classifying. Referring to the first chapter, introducing the systems and classifying computer systems. The second serves introducing processes, promising further illustrations and giving metastatements.

Basic Concepts

In 'Basic Concepts' the first step is then started on page 41. The communicative functions of introducing, explaining, exemplifying

referring to figures and mathematical calculating are there in the first three parts of the third paragraph. The fourth serves referring and inferring. The fifth serves developing the topic and the sixth presents possible applications and gives a summary.

Storing Programs

'Storing Programs' starts on page 41-45. Pages 42-44 are reserved for very useful figures. The first paragraph is meant for describing and defining. The second paragraph serves instructing, the third describing step-by-step operating, the fourth comparing and explaining, the fifth for elaborating, the sixth for defining and exemplifying in figures, the seventh for naming and the eighth for summarising and concluding.

Under the term 'Microcode', we have four paragraphs. The first serves identifying, comparing, the second explaining, the third summarising and the fourth serves projecting, suggesting, comparing and mentioning advantages and disadvantages or contrasting.

Functional Units

A paragraph on page 47 follows the 'Microcode'. It serves introducing the functional units and enumerating them.

The Central Processing Unit

This is begun with 'The Central Processing Unit' - CPU - which is presented in four paragraphs. The first paragraph on the CPU serves the function of defining, history-telling, subdividing and recapitulating. The second serves explaining, the third describing and the fourth serves comparing, enumerating and concluding.

Secondary Storage Devices

The 'Secondary Storage Device' is not given much space, only two paragraphs. The first serves explaining, enumerating and the second serves describing and comparing.

Input and Output Devices

The 'Input and Output Devices' are discussed in four paragraphs on pages 49 + 51 because 50 is completely reserved for figures. They serve introducing, defining, developing and summarising. Figures are there for more elaboration.

The System Console

The 'System Console' is tackled in five paragraphs on pages 51 and 52 along with one figure only. The first paragraph serves the communicative function of defining and describing, the second developing, the third elaborating, the fourth comparing and the fifth serves describing, comparing and concluding.

Communicating with the Computer

'Communicating with the Computer' occurs on pages 52 and fifty three. 'Signing on', 'Entering the Program', and 'Signing off' follow on later pages 53-56. They are followed by the 'Chapter Summary' and discussion questions on page 57. The first paragraph in 'Communicating With the Computer' serves introducing and describing.

Signing on

The first paragraph in 'Signing on' serves explaining and process describing; it refers to figures as well. The second serves describing, synthesising and elaborating.

Entering the Program

'Entering the Program' consists of six paragraphs and a figure on pages 54-56. Taken consecutively, they serve 1 - explaining, 2- process-describing, 3- elaborating, 4-hypothesising, 5- developing and 6- concluding and advising.

Signing Off

'Signing Off' on page 56 occurs in two paragraphs. The first serves describing and the second serves concluding. The rest of page 56 is left for Chapter Summary and serves the communicative function of summarising. What remains is page 57 where discussion questions are and this, of course, serves the communicative function of exercises.

As is seen from the analysis of the chapter, the communicative functions used are the same as those utilised in T.F. Fry's text. Two more points should be mentioned; the first is the use of chapter summary by Marilyn Bohl and the next is the use of index and glossary. Both are not included in T.F. Fry's text.

Regarding grammatical realisations, there has not been any strict rule or fixed usage of a form to suit a single purpose. More than one form can be used for an instruction to the computer to stop working e.g. Stop, End, or Bye or O.K. or even automatic programming.

5.8 Salient Points

While analysing texts, interest was directed to both semantico-grammatical relations and communicative functions. The latter has been extensively dealt with; since it is almost in

every line of the text, whereas the former varied very much.

We came out with the conclusion that there cannot be any specific grammatical form that is only used to convey a certain function. However, we have found out that certain usages are recurrent in both texts:-

- (a) The recurrent use of the present simple throughout the texts. It has been used 175 times by Bohl and 67 times by Fry. The difference in number is related to the length of texts; it is the main cause of difference. The utilisation of this tense refers to factual knowledge and instructions, a characteristic of scientific texts.
- (b) The passive has been used by both, 159 times in the text by Bohl and 30 times in the text by Fry. This denotes emphasis on operations or processes, not on persons or doers. Interest in results or output obliges users to utilise the passive.
- (c) The use of the gerund; sometimes called verbal noun. It has been used 128 times by Bohl and 20 times by Fry. Gerunds serve as subjects, objects and instead of verbs. Besides they recur as words related to certain operations and processes which call for lexical signalling. This makes them very much in demand.
- (d) The use of the infinitive, 91 times by Bohl and 20 times by Fry. Catenatives are usually accompanied by infinitives.
- (e) The use of modals like can, may etc. 80 times by Bohl and 30 times by Fry. Their utilisation allows for shifting form of emphasis.

- (f) In flowcharting instructions are the recurrent feature. They are needed simply because they play a certain role of directing, manipulating etc.
- (g) The use of conditionals. This issue has not been as recurrent as that of the passive, the present simple or other previously mentioned points. Yet the knowledge of such structures is of interest to learners so as to help them understand subject-specific computer science texts aimed at.
- (h) The utilisation of cohesion and coherence has been noticed. The general layout of the chapters has been noticed as having a title, a beginning, subdivisions, a close and exercises or discussion questions at the end. Bohl's text is backed by a chapter summary, unlike Fry's which is not. Also Bohl's has been richer in figures and coloured photographs which form integral and exemplificatory parts in and for the text.
- (i) The use of certain words commonly known but with uncommon meaning that is particular to computer programs, or form e.g. The words 'bug' and 'debug' for 'error' and correct the error. Also the use of the word 'program' in one form only.

We have noticed that communicative functions are not tied to one grammatical form. Indeed the same grammatical form may appear in other functions which proves our point of view. As an alternative, we suggest laying emphasis on or including salient lexical items to be taught in context in any ESP course design. So the salient grammatical points or issues, plus the basic

minimum of grammar and the salient lexical items in the discipline aimed at would form foundation stones in laying any effective course design, if planned to be subject-specific, appropriate, relevant and motivating. These, of course, should be gathered after the necessary research has been done to ensure relevant, satisfactory, motivating and successful course design based upon the broad researched needs we suggested.

In the next chapter the researcher will deal with classroom lectures and classroom interaction in order for him to be able to find suitably documented systematic basis for elements to be included in the needs for ESP course design.

C H A P T E R S I X

THE CONTRIBUTION OF CLASSROOM LECTURES
AND CLASSROOM DISCOURSE TO NEEDS ANALYSIS

6.0 Introduction

The teacher, the student, the classroom, the book and the aids needed for carrying out the teaching-learning according to a pre-arranged plan are important elements for a successful teaching-learning process. The teacher and the student are the most important parties in this process. The teacher, being a representative of an educational organisation or institution, wants to ensure that the job he is responsible for is being properly done. For this purpose he is to follow a certain plan - syllabus, and to utilise an appropriate theory, method or an approach, his own approach or one which had been determined by others.

The adult student is to follow up instruction in order for him to achieve in a purposeful learning process. He is to take this course of instruction or study, for a certain purpose e.g. to work as an assistant executive, a computer operator or programmer etc.

Both the teacher and the student have something in common; one emits planned information and/or instruction and the other is to utilise this for his own good. For this common, shared purpose, there should be the traditional meeting place and that most probably would be the lecture hall, the workshop, the English lab or the most traditional of all, the classroom.

The researcher has limited the process of teaching-learning for the classroom for his own purposes although he already knows that teaching-learning can be carried out at home through a tape recorder or a video or in the most uncommon place one could imagine. Lots of software on the market support this idea.

In fact as Abbot and Wingard (1981:14) rightly put it:-

"Learning is something that people normally do all through their lives - there does not have to be a teacher. But no one has seen it happening; as an activity it is invisible".

For planned learning to take place there has to be a learner with a purpose, a means and the party that offers this educational service, the teacher. Practitioners with an excellent long experience and expertise, Abbot and Wingard have their say:-

"Teaching, on the other hand, is an observable activity. Perhaps that is why we (Abbot & Wingard and others in the same profession), teachers are much more happy to talk about teaching techniques than about learning processes. We recognise that a good teaching technique is one that 'works', but we tend to forget that, if it does work, it must be because in some way it harmonises with the student's learning techniques". (Op Cit)

It is the content of the last statement in the quotation that the researcher wants to fulfil i.e. harmony between learning and teaching for the reciprocal benefit of both a successful teacher and a successful learner, and in the end an advantageous output for all parties concerned in the teaching-learning processes.

6.1 Teaching-learning Harmony

The teaching-learning processes should have been determined and utilised according to the needs of the parties involved. They are the students, their teachers and their employers. The

category of students whose needs are being served should feel the harmonious nature of the situation they are in.

If teaching and learning do not go smoothly together towards the purpose, then there will be a loss; that is what is sometimes called the drop-out. These are the learners who could not adapt to the teaching-learning situation. They were either asked to leave or they chose it themselves since they felt they would not be able to achieve what they had aimed at. This loss is mainly due to the inadequate attention paid towards their needs.

6.1.1 The Ability to Learn and Individual Differences.

Abbot and Wingard have their opinion regarding this teaching learning situation, with reference to language learners. They (1981:23) point out the fact that:-

"Every normal person has sufficient cognitive 'thinking' and sensori-motor ability to learn a foreign language; but simple observation of language-learners shows that there are individual differences".

The researcher agrees with Abbot and Wingard concerning the ability and the individual differences between and among all learners. From this statement, the researcher can draw a conclusion. This conclusion is the existence of successful and unsuccessful learners. But he also adds that if the needs are not attended to, frustration and failure on the students' part become a natural result.

6.1.2 Successful and Unsuccessful Learners

A successful learner is unlike an unsuccessful one. The former achieves his aim but the latter does not. The unsuccessful may have failed to perform properly in one, two or all of the steps

in the following quotation from Abbot and Wingard (1981:15):-

"But I am sure that successful learning involves at least three things: being able to understand something, being able to remember it and being able to make use of it".

Indeed the researcher wants his students to be able to understand the discourses of their disciplines, to be able to remember what they learned, and to be able to make use of it in relevant situations and appropriate contexts. Students and teachers may fail to do so if the needs of the students are not attended to and the views of the teachers are not taken into consideration. Both students have their own needs which should be catered for and the teachers have their own views which contribute to the success of students while studying and, eventually, in their careers.

In this chapter, lectures will be analysed for the sake of promoting ESP students' understanding of content as a partial fulfilment to the needs of the triumvirate that should be taken into account in the needs analysis process.

6.1.3 Eclecticism

With reference to the means of learning i.e. adopting a certain method or approach, the researcher supports communicative teaching methodology which is adequate and suitable to the needs of students. But he also supports eclecticism in doing so. That is he will mainly utilise communicative techniques, activities and strategies but he will not hesitate to resort to any means he may find helpful in achieving his aim. Abbot and Wingard are of identical opinion regarding eclecticism. They (1981:36) point out that:-

"People have for centuries learned languages from teachers using all sorts of approaches. There is no reason why we should feel obliged to adopt just one, and every reason why we should use the strengths of several. 'Either/or' attitudes seldom help; 'both/and' attitudes often do".

6.1.4 Attending to the Needs of Students, Teachers and Employers

The preceding quotation refers to the method or approach.

Regarding the needs of the students, the researcher agrees with Van EK (1979:103) that teachers should enable language learners to make use of the language; they should not simply learn it as paradigms, but should put it to its use:-

"The aim of learning is always to enable the learner to do something which he could not do at the beginning of the learning process".

This learning should have been effected by the needs of the triumvirate the researcher is defending. The teaching-learning processes occur mainly in the classroom. They have their aims which are built on:-

- (a) Educational or pedagogical basis,
- (b) Cultural, including social basis,
- (c) Linguistic basis,
- (d) Communication basis, and
- (e) Pragmatic basis.

These bases should be taken into account for learning purposes or, at least, the ones relating to the aims of learning made effective by the students' academic institution as in (a), their society as in (b), by their teachers as in (c) and through themselves and their employers as in (d) and (e).

6.2 Objectives

This chapter aims at the following:-

- (a) Presenting types of lectures as in teaching learning situations in KBI.
- (b) Analysing three KBI computer science lectures (Appendices D1, D2 and D3), and adopting various elements from different approaches to text analysis.
- (c) Presenting the functional, linguistic, discoursal and communicative aspects that the analysis will contribute to a needs analysis for an ESP course for computer science students in KBI.
- (d) Establishing documented systematic evidence for the inclusion of the analysis of classroom subject-specific lectures in the design of ESP courses, mainly for KBI computer science students.

6.3 Analytical Approaches to Lectures

An entirely appropriate approach to ESP course design has not been reached yet due to many factors. The most important among them is the inadequacy of the needs analysis underlying such courses. These ESP courses have covered different areas such as reading for learning e.g. in the sciences or listening for understanding lectures. The researcher intends to discuss lecture style and discourse so as to establish a basis for the inclusion of their analysis as a partial prerequisite to appropriate needs analysis and ESP course design.

6.3.1 Listening to Lectures

A lecture is a form of address whose aim is to instruct individuals or groups in a certain area and for a certain purpose. Different lecturers use different modes of lectures that suit their purposes. Lectures have recently been described as forms or kinds of discourse. Dudley-Evans and Johns (1981:34) have been able to identify three types of lectures:-

- (a) the reading style
- (b) the more informal conversational style, and
- (c) the rhetorical style.

These three types or categories are also referred to in Chaudron, C. and Richards, J. (1986:114) as adopting three styles.

6.3.1.1 Style A - 'Reading Style'

"The lecturer reads from notes, or speaks as if he was reading from notes, characterised by short tone groups and narrowness of intonational range. Falling tone predominates". (Op Cit)

This style is applicable to the lecture by Mr. Zahir Sartawi, who is a lecturer in the Computer Science Department in KBI. The transcription of this lecture is in Appendix D1.

Sartawi was delivering his lecture as if he was reading from notes, with confidence and clarity. This could be understood through listening to the original lecture recorded on tape for purposes of this research. He used short tone groups though he gave intervals for queries. The utilisation of micro-markers was apparent: "OK" and "now", "actually", "in fact" and "obviously". His falling tone of voice could be the signal of withdrawal from interaction. This signal of withdrawal from interaction has been represented, in the researcher's opinion, in the lecturer's clarity

of presentation, exemplification and very effective repetition which includes lexical signalling and more emphatic referring to what has already been said. The researcher will analyse this lecture for the general aim of broad needs analysis. His aim will be mainly based on terms of language content.

Candlin and Murphy as one team of the KAAU project analysed lectures for the sake of establishing an approach to promoting ESP students understanding of lectures.

6.3.1.2

The second style in the three categories quoted is:-

Style B or 'the Conversational Style'.

"The lecturer speaks as if he was reading from notes. Characterised by longer tone groups, and key-sequences from high to low. When the lecturer is in "low key" at the end of a key sequence, the speaker may markedly increase tempo and vowel reduction, and reduce intensity".
(Op Cit)

This category of lecture could well be applied to Almukbil's lecture. Almukbil is a computer science lecturer in the Computer Science Department in KBI. He spoke mostly informally (see Appendix D2 for the transcription of the lecture which clarifies this). Almukbil's took the form of the more informal conversational style. This conversational style could be seen in the effective conversation steps or the division of roles between the lecturer and one of his students and among many of the participants in the classroom. The lecturer mentions names and tends to allocate roles.

The researcher feels the definition of role should be highlighted here, since it will be recurrent in this chapter, due to its importance within a discussion of interactants in classroom

lectures.

Munby, J. (1978:68) wrote:-

"A role, then, is an expected normatively defined, dynamic pattern of social behaviour associated with a particular position, implying a relationship with other roles, and to which behavioural pattern individuals are likely to conform in varying degrees".

The roles here are the roles of teachers/lecturers and students; each category is expected to behave within the dimensions of their role. These patterns of roles may underlie the behaviour, the social relationships and the classroom interactions, certainly with varying personal traits. Almukbil was kind enough to hand in a shorter form of his lecture. It is especially useful for it contains 5 drawings which contribute to the clarity of the text. The form will be included in Appendix D2 also as D2*.

6.3.1.3 Style C or the Rhetorical Style

"The lecturer as performer. Characterised by wide intonational range. The lecturer often exploiting high key, and a 'boosted high key'. Frequent asides and digressions marked by key and tempo shift- sometimes also by voice quantity shift". (Op Cit)

This Rhetorical style of lectures could be the style of Almahmeed, who is currently a lecturer in computer science in KBI. His handwritten summary of his lecture will be dealt with in this chapter along with the two other lectures we referred to. The researcher did not succeed in recording Almahmeed's lecture due to some unexpected technical fault in the equipment. All three lectures by KBI computer science lecturers will be analysed in this chapter.

The researcher agrees with Cleary, J. (1978:30) regarding the usefulness of recording lectures.

"This-recording lectures-is a potentially useful area in that these recordings will provide information of the type of language actually used and of the different levels of scientific content and language complexity which may occur in a lecture".

There are three useful points relating to language. They are the type of language actually used in lectures, the different levels of scientific content and the linguistic complexity. The researcher adds the relevances that these points add to the needs analysis he is supporting. Getting useful practical results from recording and analysing lectures so as to use them in designing courses for the students whose subject-specific course lectures are being recorded.

6.3.2 Lecture and Text

Lectures are forms of address and texts are records of communicative acts. The first is spoken and the second is written. There are differences between written and spoken texts. The first type is linear, orthographic and is governed by punctuation marks and is usually formal. The latter is heard or spoken and is governed by tone of voice and intonation. As it is known, the written text can be usually typed, but the spoken one is if necessary recorded and later transcribed. Recording preserves the original elements of the text and other elements that are extraneous to it. As Brown and Yule (1983:9) put it:-

"The simplest view to assume is that a communicative act will preserve the 'text'. The tape-recording may also preserve a good deal that may be extraneous to the text-coughing, chairs, creaking, buses going past, the

scratch of a match lighting a cigarette. 'We shall insist that these events do not constitute part of the text (though they may form part of the relevant context)''.

The researcher agrees with this view of Brown and Yule as to the matter of these extraneous elements.

6.3.3 Classroom Discourse

Sinclair, J. McH. and Coulthard, R.M. (1975:42) based on the Social Science Research Council Report of August 1972 write that discourse in the classroom consists of units like 'lesson', 'transaction', 'exchange', 'move', and 'act', in descending order. They deliberately chose the pedagogical evidence in a situation that necessitates such ranks. For them levels and ranks go under the following - Grammar, Discourse or Social functions and non-linguistic or paralinguistic titles. Sinclair and Coulthard (1975:24) and Coulthard (1977:102) have put them in the following manner:-

Non-linguistic Organisation	Discourse	Grammar
Course Period → Topic →	Lesson Transaction Exchange Move Act →	Sentence Clause Group Word Morpheme

Sinclair and Coulthard (1975:27-28) add:-

"Grammar is concerned with the formal properties of an item, discourse with the functional properties, with what the speaker is using the item for".

It should be clearly mentioned that the authors borrow Halliday's model of 'Categories of a Theory of Grammar'. As is mentioned in the introduction: (1975:1)

"This work is based on the Research Project: 'The English Used by Teachers and Pupils which was started in September 1970 and finished in August 1972. It is mainly for the analysis of classroom discourse".

We can say that theirs is pragmatic discourse analysis.

6.3.4 Spoken and Written Discourse : A Practical Approach

The emphasis on the practical side by Sinclair, J. and Brazil, D.C. (1982) in their 'Teacher Talk' has stemmed from 'Towards An Analysis of Discourse' 1975 in its linguistic analysis of discourse. The description of intonation has been tackled by Brazil in the second part of the book (1982:22-23).

Sinclair describes what teachers do in the classroom. According to him teachers:-

- (a) tell pupils things;
- (b) get pupils to do things;
- (c) get pupils to say things; and
- (d) evaluate the things that pupils say or do.

Regarding the work in the classroom Sinclair divides it into three main areas of activities:

- (a) The subject matter of lessons,
- (b) The organisation of lessons, and
- (c) The disciplinary side of a large group working together.

In these, verbal and nonverbal activities exist. It should be expected that different selections of these activities may exist.

In his summary of the units of discourse, Sinclair (1982:53-54) summarises the units of discourse in tabular form. It is clear that Sinclair has omitted 'lesson' recently due to its being non-linguistic-

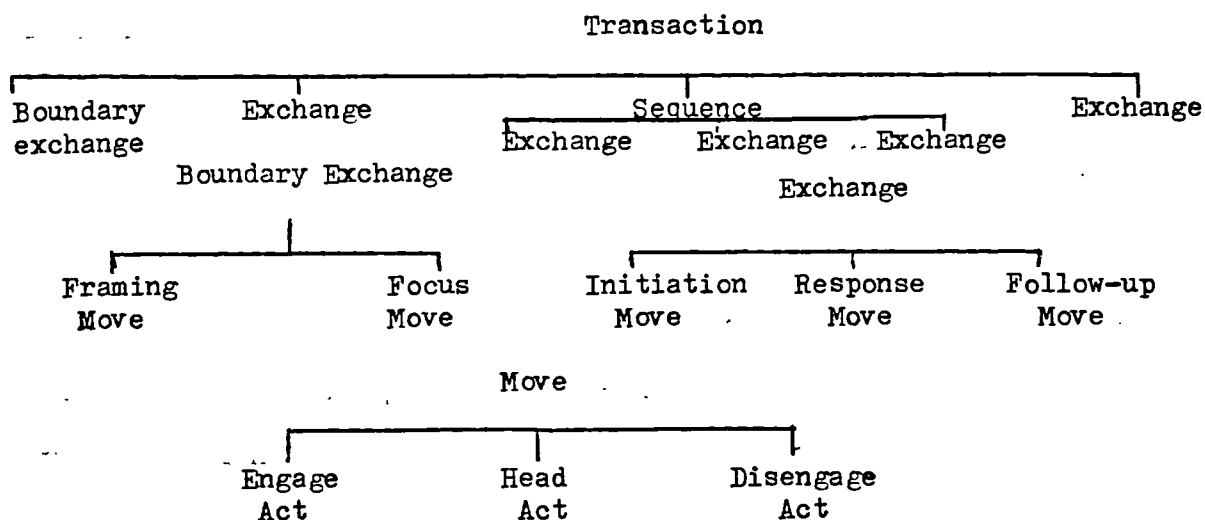

Sinclair gives the definitions of the units of discourse (in ascending order):-

- (a) Act = smallest unit of discourse.
- (b) Move = minimum contribution by one speaker and comprising one or more acts.
- (c) Exchange = minimum unit of interaction and comprising one or more moves.
- (d) Sequence = intermittent: marked by stylistic constraints and comprising more than one similar exchange.
- (e) Transaction = marked by boundaries and comprising one or more sequences or individual exchanges.

He then gives the basic structure of teaching exchanges which is:-

Initiation - Response - Follow-up.

He gives alternatives with practical examples. This makes his work on classroom discourse practical and very illuminating. Yet more-research is needed in such areas as classroom and lecture discourse especially where little or nothing has been accomplished. Sinclair (1972), Halliday(1976), Labov (1972), Hymes (1972), Grice (1975) and Kempson based their work on discourse. Austin and Searle based theirs on the sentential level but as we have seen a sentence cannot always provide a full context. It can perform one act at a time. The sentence in a text cannot always convey its own separate meaning and can also convey another meaning if we take it aside. Without context with other sentences. We are interested in the text as a whole, a unified whole, a semantic whole and as a communicative event - not as separate sentences of 'Teacher Talk'.

Brazil, in the second part, focused on intonation, pitch, pitch level and pitch movement in spoken discourse. He started it from the move between speaker and hearer. He then referred to the keytone and how it changes, how users could change or affect the message in the classroom.

Brazil (1982:152) describes 'Key' as

"a significant set up to a higher level or a significant step down to a lower level at a particular syllable which may be the tonic syllable or an earlier one". 'Tone' as in Brazil, 'is realised by pitch movement at the tonic syllable'.

The change of 'key' from low to high in the classroom may serve a function. The teacher is the one who is capable of doing this. In the end both Sinclair and Brazil give a practical example of

how classroom discourse could be analysed. They did that through analysing the discourse into eleven exchanges of varying nature. These exchanges included 44 moves which referred to 'tone' and 'key' and their placement on words or syllables.

We should not overlook Winter's role in text analysis and related studies. According to Winter (1976) a text can be analysed in terms of one of four permutations of situation, problem, solution and evaluation.

Winter produced materials mainly for native-speaker science students on communication skills. But these have obvious relevance to ESP. It is true that Sinclair's was applied to school pupils, but the type of interaction that occurs is nearly identical to that which occurs in an adult situation except that the adult world is richer in resources, experience and a more specialist subject as in ESP courses. It is worthwhile mentioning that more freedom of expression, interaction, role-playing and open-ended activities in ESP classroom are normal and motivating practices for an ESP student. The length of the lecture could well contribute to its being or forming a whole discourse of an overall topic which may be attractive for both the ESP teacher who wants to tackle a whole topic and an ESP student, who is eager to understand the discourse being discussed.

Sinclair's was with school pupils whereas Murphy and Candlin's and Chandron and Richard's were with university students whose needs were being investigated.

6.3.5 Candlin and Murphy

Murphy and Candlin's research in the KAAU project on listening comprehension which was carried out in the mid-seventies is the most relevant to the researcher's area due to the homogeneity of Saudi and Kuwaiti students and the nature of the research which concentrates on the discursal aspects of lectures. These aspects contribute to the analysis process, promote understanding and eventually the comprehensibility of lectures and classroom discourse. Their approach was based on the functional aspects and the organisation of lectures. They identified *markers of both kinds*, macro and micro. They also included metastatements and starters.

In fact the researchers were trying to help students especially non-natives to be able to fully understand lectures through research to discover the things in the lecture either in the form or the functional organisation that would help the students fully understand it. Candlin carried on with his similar researches in the UK, e.g. on Doctor-Patient Discourse and Doctors in Casualty.

6.3.6 Brown and Yule

Brown and Yule (1983:ix) made their approach to discourse analysis clear in their introduction. They wrote:

"We examine how humans use language to communicate and, in particular, how addressers construct linguistic messages for addressees and how addressees work on linguistic messages in order to interpret them.... but our primary interest is..., to give an account of how forms of language are used in communication".

For them 'The analysis of discourse is, necessarily, the analysis of language in use'. They describe the 'transactional'

function or that of the content and the 'interactional' or that of the social relations or personal attitudes. The former is the one that conveys factual content or propositions and the latter deals in-language which is used to establish and maintain social relations. Brown and Yule described the transactional function of language on the one hand and the interactional one on the other. For them (1983:3):

"Conversational analysts have been concerned with the use of language to negotiate role-relationship, peer-solidarity, the exchange of turns in a conversation, the saving of face of both speaker and hearer".

Brown and Yule have examined most opinions of theoreticians in discourse analysis along with discourse analysts regarding both the function and structure of discourse. Yet they (1983:271) conclude:-

"We have concentrated on questions relating to reference and to the general issues of coherence and relevance. We have left virtually untouched several areas which occupy scholars working on the interactions of semantics and syntax-questions of aspect, tense, modality, quantification, negation, adverbial modification and so on, as well as relevant issues like the influence of metaphor in the interpretation of discourse".

6.3.7 Chaudron, C. and Richards, J. (1986:113-114) wrote about lectures and listening comprehension. They also referred to (Clark & Clark 1977) as having contributed to a greater understanding of listening comprehension. Chandron and Richards wrote that:-

"Two basic processes that have been identified are referred to as bottom-up processing refer^s to the analysis of incoming data, and categorising and interpreting them on the basis of information in the data".....Top-down processing involves prediction and inferences on the basis of hierarchies of facts, propositions and expectations and it enables the listener or reader to by-pass some aspects of bottom-up processing".

After describing both types Chaudron and Richards add that a combination of the two levels is needed for comprehension.

They did research which dealt primarily with lectures in the reading style or style A mentioned before. They (1986:114) believe that:-

"In view of the didactic focus of lectures, the structuring and organisation of information within a lecture has been assumed to be an essential aspect of its comprehensibility".
(Op Cit)

They also refer to many researchers who engaged on lecture comprehension like Cook (1975) who examined the functions of connectives and other devices which serve as pointers to topic continuations. Cook also focussed on the rhetorical organisation of the discourse of the lecture and how it is signalled. He was able to point out markers that point back and forward in the discourse relations and contribute to discourse unity.

Chaudron and Richards (1986:116) also mention (Young and Fitzgerald: 1982) who in 'Listening and Learning' devised exercises for learners:-

"...to identify discourse markers with the functions of addition, comparison, contrast, exemplification, explanation, restatement, result, sequence, summation and transition".

Chaudron and Richards carried out research 'to explore the effects of discourse signals and markers in lectures on second-language learners' comprehension'.

Four different versions of lectures were recorded, each version including different combinations of macro and micro discourse markers. Then the recorded lectures were played to

students. The subject of the lecture was the expansion of the United States from thirteen colonies to an imperial nation was condensed to a seven-page lecture. The versions included:-

- (1) baseline version which included nothing extra added except what is necessary for the text.
- (2) Micro version with various micro-markers for framing, intersentential relations and pause fillers.
- (3) Macro version containing signals or metastatements about the major positions within the lecture or the important transition points in the lecture.
- (4) Macro-micro version or the combination of versions two and three.

Subjects were pre-university and university groups. They were mixed but predominantly of Asian and Pacific ethnic and linguistic backgrounds.

The pre-university students were met in the classroom whereas the university students could do the exercise in the language laboratory. No note-taking was allowed. The students were given instructions and a cloze test. The students were given two short listening practice passages. The lecture was then played and the subjects were given first the multiple-choice questions to answer, then the true-false quizzes. The tests took place in spring, summer and winter of 1984.

The results of the cloze test for the university students were higher and were reliable while those of the true and false quizzes were higher but not so high as to warrant their being used in further analyses.

The general result indicated that the macro version covariance adjusted-mean was the best; it was followed by the macro-micro version while the baseline and the micro versions were similar.

In conclusion Chaudron and Richards^s (1986:124) recommend the macro-markers versions:

"A lecture which uses more macro-markers is likely to be easier to follow. On the other hand an over-use of micro-markers possibly detracts from the overall coherence of the lecture. For the curriculum and materials developer, and for L2 teachers, the macro-markers probably constitute a relevant focus for second-language classroom activities and instructional materials. Such a focus is often lacking in current published materials".

Such systematically documented opinions are worth taking into account since they are based upon research into classroom activities. Every research will throw light on new perhaps not yet exploited areas.

6.4. Significant Elements in Lectures

The researcher believes that lecture discourse analysis should concentrate on the following, knowing that some of these have been already adopted or are being so. In his analysis of KBI lectures, he will use them:

- (i) The overall organisation of lectures relating to
 - (a) information organisation, and
 - (b) information content.
- (ii) Macro-markers in lectures.
 - (a) metastatements e.g. "Now we go to the second style"
"Let's go to the first stage"
"Our lecture for today is Computer Components"
 - (b) Starters e.g. "Well, let us start our topic of today"
 - (c) high level information signals e.g. "This is not the end of the story"...., "The next topic we will discuss is Input/Output devices."

- (iii) Micro-markers in lectures e.g.
 - (a) temporal e.g. "now," "often," "then," "after that" etc.
 - (b) causal e.g. "due to," "because of," "so" etc.
 - (c) contrastive relationship e.g. "but," "indeed," "on the other hand."
 - (d) relative emphasis e.g. "of course," "you see" etc.
 - (e) framing e.g. "OK," "well," "right" etc.
- (iv) The functions realised in the lecture and its coherence as a whole, not only its use of cohesive markers.
- (v) Recurrent structural and lexical items whose recurrence has a bearing on the discourse of the lecture and the understanding and comprehension of which contributes to promoting students' understanding of the discourse.

6.5 KBI Computer Science Lectures

Before getting into details about teachers, students, lectures and lecture analysis, it is better to set the scene for that.

6.5.1 This section aims to:-

- (a) analyse the computer science lectures delivered by three computer science lecturers in KBI;
- (b) to apply the elements previously identified in section (6.4) in the analytical process; and
- (c) to utilise both points (a) and (b) of this section in order to establish a systematically evidenced and documented basis for the inclusion of lecture discourse analysis with the broader needs analysis the researcher is advocating as a basis for ESP courses in KBI.

6.5.2 Materials

Three lectures were recorded on an ordinary cassette recorder tapes inside classrooms of the KBI for women.

- (i) The first lecture is by Mr. Sartawi, Z. It was

delivered on March, the 15th, 1986 in room no.4 the right block in an annexe called 'The Training Centre'. It started at 12.20 (5th lecture) and ended at 1,05. The number of students attending the lecture was 18, plus the lecturer and the researcher. We will refer to the lecture as, Appendix D1. The topic is about 'The Basic Elements of a Computer'.

- (ii) The second lecture is by Mr. Almukbil, A. It was delivered on the 29th of March 1986 in the same room No.4 of the annexe - Training Centre. It started at 2.15 (7th Lecture) The number of students attending was 19 plus the lecturer and the researcher. We will refer to the lecture as Appendix D2. The lecture was about 'The Magnetic Disk and the Magnetic Disk Drive'.
- (iii) The third lecture is by Mr. Almahmeed, A. It was delivered on the 15th of April 1986 in the same room No.4 of the annexe. It started on 12.20 (5th Lecture) and ended on 1,05. The number of students attending was 22 plus the lecturer and the researcher. We will refer to the synopsis of the lecture as Appendix D3. We will refer to the synopsis since we were unsuccessful in recording the lecture due to some mysterious technical fault. The lecture was about 'A Hypothetical Computer'.

6.5.3 Subjects

The subjects in these lectures are mostly (about 90%) Kuwaiti who joined KBI 1986 or the second term of 1985. Their specialisation is computer science. All the students had undergone an English placement examination referred to in Chapter Three. Some of them have been given a non-credit remedial course but the rest were allowed to register in the first credit course or English 101. The computer course - 152 - whose lectures have been recorded is the second course. It has a prerequisite which is another

junior course. This gives us the fact that the subjects have been studying at KBI for at least two terms. They have the same background and had fulfilled conditions for admission to KBI.

6.5.4 Procedures

The procedures followed to get permission to record the lectures were based on personal approach. The researcher approached Mr. Sartawi, Z. who then approached the other colleagues. They all showed interest in the research and were very cooperative during and after the recording of lectures took place.

First, the lectures were recorded on ordinary radio cassette recorder - National Panasonic RX-1830. Then the researcher transcribed the material on the 60 minute cassettes of the first two lectures - Appendices D1 and D2. After that the material of every lecture was divided up and punctuated. This has been done for ease of reading and for ease of reference as well. The overall time covered in each lecture was 42 minutes out of 45. The rest of the time was spent on disciplinary matters e.g. maintaining attendance records.

6.5.5 Importance of Lecture Analysis in ESP

The literature on the importance and usefulness of discourse analysis is plentiful. The researcher includes the following quotes as landmarks on the importance of the analysis and the benefits that may be obtained.

First, Phillips, M.K. and Shettlesworth, C.C. (1978:23) after mentioning criticisms of ESP materials as being irrelevant or

inadequate, refer to the language practice materials engender in the classroom and to the pragmatic quantity and quality of ESP materials. The researcher is doing it the other way round; looking into classroom subject-specific content and quality so as to be able to determine the needs of computer scientists.

Phillips and Shettlesworth (1978:23) wrote:

"Criticism of ESP materials is in general restricted to the adequacy with which they meet certain theoretical postulates and to discussion of the postulates themselves".

They, in fact, started by saying:-

"To our knowledge little has been done in the way of surveying the output, so to speak, of materials, that it, the kind of relevance of the language practice they engender in the classroom. This is perhaps the more surprising since the ultimate touchstone of any materials must be the pragmatic one of the amount and quality of the learning they simulate".

They support the pragmatic aspect. They also want relevance concerning the amount and quality of teaching materials to the classroom context. Indeed discourse analysis calls for a better understanding of ESP discourse. It also contributes to the area of needs analysis. This idea has been reached at after practising both discourse analyses of texts spoken and oral for the betterment of needs analysis.

Holliday, A. (1984:36) tackles discourse analysis from a new point of view; that of classroom culture. He wrote:-

"Classroom culture is something that can be observed prior to innovation created by new syllabus (course design) implementations to provide input;...."

Holliday, Hatch and Long and Phillips and Shettlesworth agree to the importance of discourse analysis and to its contribution to

the cause of better ESP output once the needs are attended to.

6.6 A Lecture as a Communicative Event

Taking the lecture as a speech event necessitates roles for people taking part in this event. These roles as specified by Hymes (1964) stated in Brown and Yule (1983:38-39) are of addressor, addressee- audience, topic, setting, channel, code, message-form, event, key and purpose.

The researcher is going to apply these aspects of the speech event to the three lectures or classroom discourse.

The following grid shows the events as they are relating to the above mentioned roles.

The Lecture as a Speech Event (after Brown & Yule)

		Appendices		
Role	D1	D2	D3	
1	Addressor	Mr.Zahir Sartawi	Mr.Adnan Almukbil	Mr.Ahmad Almahmeed
2	Addressee (Audience)	KBI Computer Scientist + the researcher	KBI Computer Scientist + the researcher	KBI Computer Scientist + the researcher
3	Topic	Computer Components	Magnetic Tape and Magnetic Disk Drive	A Hypothetical Computer
4	Setting	KBI/Teacher-student relationship	KBI/Teacher-student relationship	KBI/Teacher-student relationship
5	Channel	Speech	Speech	Speech
6	Code	English	English/ a few Arabic expressions	English/A few Arabic expressions
7	Message form	Lecture	Lecture/interaction	Lecture/Interaction
8	Event	Forty-five-minute Lecture	Forty-five-minute Lecture	Forty-five-minute Lecture
9	Key	Instructional/ explanatory	Instructional/ explanatory	Instructional/ explanatory
10	Purpose	Topic Absorption	Topic Absorption	Topic Absorption

6.7 The Representation of the Sample to Their Population

The sample selected consists of three computer science lecturers who have postgraduate qualifications in computer science . The first is Jordanian, the second is Iraqi and the third is Kuwaiti. They form 16.67% of the whole KBI computer science lecturers' population. The researcher believes that this is an internationally acceptable sample of the population studied. He also believes they represent the rest of the population in their style of lecturing in the classroom. Building upon this the researcher will carry out the analysis of classroom lectures in order to be able to pinpoint the activities, strategies and features that may contribute to computer science students' linguistic and communicative needs. Such pragmatically-based needs may then be taken into account in deciding on matters of course design.

6.8 Lecture Analysis

The researcher will analyse the first two lectures in Appendices D (D1,D2) according to the elements in section 6.4. He will apply these elements to the third D3 where applicable.

6.8.1

- (i) The overall organisation concerning form and information content.

Appendix D1

Computer components or the Basic Elements of a Computer is the information content. It occurs in 364 lines. Its organisation is in sentences which form paragraphs; Paragraphs give meaningful thoughts. These thoughts include:-

(a) A beginning (introducing the subject) e.g.

'Let us talk today....about the basic elements
of the computer'.

(b) a middle (defining, explaining, developing,
expanding....the topic introduced) e.g. lines
9 and 10.

- 'First of all we have to define the word
computer...' (line 17, starter)

- 'A computer is a machine capable of processing
data to produce information' (lines 24 and 25, defining)

- 'If we go further'...(line 34, expanding)

- 'If we draw this diagram...' (Line 48, explaining)

- 'So 'data' is just like...vegetables, meat and
this kind of thing....raw'...(Lines 68 and 69, exemplifying)

- 'Let us have an example' (Line 91, exemplifying)

- 'So let us go back to the definition...and so
on'. (Line 130, back referring)

(c) a close which marks the end of the topic.

- 'OK , now I think time is over and we have to stop
here' (line 359, close marking no further discourse-
discourse marker)

- 'And we will have next topic. It will be the
procedures of solving any computer problems...'
(Lines 360,361, projecting)

- concluding every element-component-by recapitulating
or summarising. e.g. lines 315 + 316

- 'So CPU is divided into 3 parts or three units...'
(line 312)

-'So we have 3 parts; AIU No.1 ALU No.1. Two
Control Unit, CU. Three memory OK.' (Lines 315 + 316)

This is the information structure as it is in Appendix D1.

This has been reached at, as Brown and Yule (1983:9) put it:-

"In general the discourse analyst works with a tape recording of an event, from which he makes a written representation, annotated according to his interests on a particular occasion...'

It is worthwhile acknowledging their view regarding the complex problem of preseting spoken text accurately. Brown and Yule (1983:11) rightly put it:-

"The response of most analysts to this complex problem is to present their transcriptions of the spoken text (lecture) using the conventions of the written language".

Indeed the researcher followed this process of recording the lectures first, listening to the recording, doing the transcription according to conventions of written language and right now analysing them according to the elements mentioned in section 6.4 of this Chapter.

Sartawi's Lecture

We applied a part of the first element to the lecture in Appendix D1 which relates to organisation of information in (a).

6.8.1.1 The Information Content of the Lecture

The second part relates to information content. The information content is presented in stages in the following manner:-

- (1) Introduction; e.g. 1 below
 1. 'Good Afternoon...Let us talk today a little bit about the basic elements of the Computer' (lines 1,9 & 10)
- (2) Definition of a computer which is in two parts: What people suppose it to be and what it is. e.g. 2a and 2b below:-
 - 2a. 'A computer ...to define a computer. Many people get confused about the computer and many people think the computer is a brain...' (line 12,13 & 14)
 - 2b. 'A computer is a machine capable of processing data to produce information'. (lines 24 & 25)
- (3) Lengthy central section on data, processing, and information. e.g. 3a,3b and 3c below:-
 - 3a. 'The word 'processing' when you process something it means you convert this thing from some fact to another. So the word 'processing' here, it means, it is manipulating or manipulation'. (lines 36,37,38 & 39)
 - 3b. 'Data' eh we can define it as: data is a raw material gathered from one or more sources'. (lines 58 & 59)
 - 3c. 'So information is the processed data that has a meaning to the people receiving it!'.(lines 87. & 88)
- (4) Related material added to (3) or 'data', 'processing', and 'information', namely 'manual processing' and 'EDP or electronic data processing'. e.g. 4a and 4b below:
 - 4a. 'This processing is done manually. So it is not EDP; this is manual data processing'. (line 189,190 & 191)
 - 4b. 'So what is the EDP? EDP; it is the processing that

is done by the computer'. (lines 190 & 191). This same point is given related elaboration on page 5 of Appendix D1.

- (5) Related material added to No.4 regarding the four parts of a computer. They are the input unit, the central processing unit, the output unit and the backing storage or auxiliary memory. e.g.5 below.

5. 'The computer in essence is divided into; any computer system really... is divided into four parts. The most important part is called CPU,.... CPU stands for central processing unit....So this is the first part. The second is called Input Unit. The third part is called Output Unit. So we have Input Unit, Output Unit and we will have this section here or unit here called backing storage. This unit is...(backing storage), if you do not want it, it is OK'. (lines 264 to 273) This is also expanded on page 7 of D1.

- (6) Arithmetic and Logical operations. see 6a and 6b below:

6a.'So we have really in computer...electronic data processing, in computer processing, we have two kinds of operation; arithmetic operation and logical operation. Arithmetic operation is like what? Addition, multiplication, division, subtraction and so on...'
(lines 327 - 331).

6b.'...logical operation it is like you have two statements; true and true will be true statements. True and false..

it will be a false statement . This is called
and operation/or operation'. (lines 331-334)

In a later part reference to these can be located e.g.
lines 336-339.

(7) Storing information in the memory e.g. 7 below:

7. 'And last part is the memory. In the memory here...
It is like...the human memory. The human memory,
if you put something in the human memory, it just
...(keep/s) it'. (lines 348-352)

(8) Concluding remarks: reference to written work done as a
a means of providing revision material. e.g. 8 below:-

8. 'It (next topic) will be, we'll take that tomorrow,
next topic...it will be the procedures of solving
any computer problems...' (lines 360-362)

The information content could well be put in a diagram form.
The researcher will do this in D2, whereas it was done in D3 by the
teacher himself as is shown in his drawing of the Hypothetical
Computer which is the core of his lecture.

6.8.1.2 (ii) Macro-markers

The other element in this analysis concerns macro-markers
in the lecture. These markers are usually divided into three as
metastatements, starters and high-level information signals.

(1) Metastatements exist in Appendix D1 e.g. 1 below:

1. 'Now if we go back to the definition 'Computer is
a machine capable of processing data to produce
information', so the computer has the ability to

produce information from data'. (lines 158-160)

(2) Starters e.g. 2 below:-

2. 'First of all we have to define the word computer
in order to clarify the confusion about it'. (lines 17 & 18)

(3) High-level information signals e.g. 3a and 3b below:-

3a. 'Let us talk today a little bit about the basic
elements of the computer' (lines 9 and 10)

3b. 'If we go further with the definition we can see
capable of processing data to produce information'
(lines 34 and 35)

The researcher believes many other high level information signals
could be added to 3a and 3b and so make a skeleton of the whole
lecture e.g. line 91.

"Let us have an example. Suppose "... (line 91)

"Find the average.." (line 117)

"So let us go back...." (line 130)

"So I get a list of information..." (lines 147 & 148)

and so on. This may go till the end of the lecture.

6.8.1.3 (iii) Micro-markers

The third element is about micro-markers which are usually
divided into, temporal, causal, contrastive-relationship, relative
emphasis, framing etc. For examples see 1,2,3,4 and 5.

(1) Temporal markers e.g. 1 below:

1. 'today' (line 10), 'now' (line 158), 'first' (line 17),
'just' (line 188), 'at last' (line 348) etc.

(2) Causal markers e.g. 'so' (line 349), 'if' (line 171),

'in order to' (line 297) etc.

- (3) Contrastive markers e.g. 'just like' (line 68),
most important (line 320)
- (4) Relative emphasis markers e.g. 'completely' (line 29)
- (5) Framing markers e.g. 'OK' (line 359) 'Here' (line 75) etc.

6.8.1.4 (iv) Functions Realised in the Lecture

The fourth element concerns the functions realised in the lecture and its being coherent as a whole through both cohesion and coherence.

Coherence to start with is achieved in the first lecture D1, through its presentation of a topic and that is 'The Basic Elements of the Computer'. The presentation explicit in the overall organisation we discussed at the beginning of section 6.8 of this Chapter clearly shows the coherence or its being a whole. As a topic it has: a beginning which is the introduction plus the topic as elements of the computer and its definition. The development of the topic representing the elements of input/output, central processing and the backing or auxiliary storage unit expounds the topic. There are also the subdivisions of the central processing unit and the processing of data and/or operations. Then there is the close which starts from line 359 till the end. It announces the lecturer's intention to stop as time is over and his intention to start a new-next topic-topic tomorrow.- which is another day. It also shows that the lecturer had given his students an assignment which is a sort of referring back to get all threads of the present topic, the last one and the next one together.

Many functions are realised in this lecture. They serve the communicative functions in the following:-

1. Introducing persons and topics e.g. 1a and 1b below:-

1a. 'Let us welcome Mr. AL-Attili today....So we welcome Mr. Ismat as our guest today'.

1b. 'Let us talk today a little about the basic element(s) of the computer'.

2. Defining and naming. e.g. 2a, 2b and 2c below:

2a. 'A computer is a machine capable of processing data to produce information '.

2b. 'Data is raw material gathered from one or more sources'.

2c. 'The most important part is called CPU'.

3. Exemplifying e.g. 3a and 3b below:-

3a. 'The computer is completely like a slave and you program this slave to do this and this and this...'

3b. 'Control Unit - CU, we can see, it is like the traffic controller....So it is like the traffic light'.

4. Contrasting e.g. 4 below:-

4. 'The human factor is very important because the human factor is the main-most important factor in data processing'.

5. Analogy e.g. 5 below:-

5. 'The computer is a machine; it is not anything else. It is completely like a refrigerator or it is like a television....'

6. Explaining e.g. 6 below:-

6. 'A computer is a machine capable of processing data to produce information. So we have to stop a little bit about some words here:-

A 'machine' and the word 'processing' and the word 'data' and the word 'information'.

Other functions like describing, elaborating and developing can go with this function of explaining but it depends on how much one wants to say. If the speaker gives a definition or a name, it will be naming or defining, whereas if he adds another statement, it can be describing. If he added more, it would be elaborating and if he still took the topic further to another stage, it could be called developing.

7. Metastatements e.g. 7a and 7b below:-

7a 'First of all we have to define the word computer to clarify the confusion about it'.

7b 'We hear about the word 'data' and the word 'information'. Let us define the word 'data' '.

8. Back referring to topics or ideas treated before; it may be referring forward to next topics to be dealt with e.g. 8 below.

8. 'It - topic - will be, we'll take that tomorrow, next topic...it will be the procedures of solving any computer problems and it might be written in your assignment...'

9. Comparing e.g. 9 below:-

9. 'The control unit is just like a traffic controller...
so it is like a traffic light ".
10. Emphasis through repetition e.g. 10a, 10b, 10c and 10d below:-
- 10a 'A computer is a machine capable of processing data to
produce information'. (lines 18 + 19)
- 10b 'A computer is a machine capable of processing data
to produce information.' (lines 24 + 25)
- 10c. 'If you manipulate these data by the computer,
you can get information'. (lines 77 + 78)
- 10d 'If we processed data, we will get information;
information. It is processed data...' (lines 171 + 172)
11. Classifying e.g. 11a and 11b below:-
- 11a 'Data is raw material'
- 11b 'Information is the processed data'
12. Rhetorical use of questions for emphasis. e.g. 12a and 12b below:
- 12a 'So data...it is just like what?...these things
raw, vegetables and meat...not cooked'.
- 12b 'What should I do? I have to find the average
of these scores'.
13. Apologising e.g. 13 below:-
- 13 'So data...it is completely different, has no meaning.
It is a meaningful information; sorry. Information has
a meaningful result'.
14. Concluding e.g. 14 below:
- 14 'I think now time is over and we have to stop here
and we will have the next topic...'

It should be mentioned after pointing out more than fourteen functions - few functions were included in No 6-that the researcher considered the most prominent functions. Sentences or paragraphs could convey more than one function and functions themselves overlap. Yet the examples clearly represent the functions exemplified.

6.8.1.5 (v)

The recurrent structural and lexical items whose recurrence has a bearing on the discourse.

1. The use of the present simple for factual statements.
e.g. 'introduce' 'think', 'define', 'get', 'produce',
'process', 'write', 'put', 'store', 'program' 'consists',
'convert etc'.
2. The use of modals e.g. 'can', 'could', 'will', 'would',
'might', 'should'. This use causes differences in meaning.
3. The use of conditionals e.g. a, b and c.
 - a. 'If we process data, we will get information'
 - b. 'If we go further, we can see capable of processing data to produce information'.
 - c. 'If you have some kind of vegetables, meat..., you can't eat them raw'.

This use of conditional sentences refers to interrelated events; if this happened, then this will happen or may happen or can happen as the case may be.

4. The use of the passive e.g. a, b and c.
 - a. 'This is called information'
 - b. 'The nice meal is called 'information'.

c. 'This processing is done manually'.

5. The recurrent use of 'And', 'so' and 'OK' as micro markers.

a. 'So data'...

b. 'So the information.....'

c. 'So we have data'..

d. 'So if we leave the computer'

e. 'So I have.....'

f. 'So let us go back to the definition.

g. 'Aisha will get 60 and so on'

They act as discourse markers, fillers and to attract attention.

6. The use of the gerund e.g.

'processing'. The computer is capable of processing data to produce information'.

7. The use of deliberate repetition to serve as revision or reinforcement. Many examples could be given of this

repetition. The prominent examples are the words:

'Computer', 'processing', 'data', 'information'. These

have been repeated throughout the discourse from the beginning till line 255. e.g.

'I can stop here and just leave...a couple of minutes for you to ask about the data, term data, term information, term computer'. These are very important terms and I hope....I suppose that everyone of you should know these terms clearly...'

The case is nearly the same with the sections of the computer units like 'CPU' and its consisting of 'central processor', arithmetic logic unit, control unit and memory'.

8. The recurrent use of 'have to' e.g.

- 'In this section we have to store our data or our information. So...eh, so here we, we have to talk a little bit about section...'

- 'First of all, we have to define the word computer'

- 'So we have to define the word 'processing'...

This use of 'have to' is on marker of logical operation or relation in the lecture text.

9. The lexical items that dominate are topic-related ones

e.g. computer elements and related definitions. These include the following: 'computer', 'machine', 'processing', 'data', 'information', 'I/O unit', 'CPU', 'memory' 'ALU', 'CU' and, 'Auxiliary memory'.

These elements to a computer scientist, 'Computer Components' or 'Basic Parts of a Computer', hence their importance

6.8.2 Almukbil's Lecture

This lecture; D2 will be analysed on the same lines as in section 6.4 whose elements were applied to Sartawi's lecture in D1.

6.8.2.1 (i) The overall organisation

This - D2 - lecture has taken the form of 'oral address' and for analysis purposes, the researcher transcribed it in paragraphs. It had taken the form of a topic which we can analyse in the following manner:

(1) a Preparation for or introduction of the topic. e.g.

1a below:-

1a 'As usual....em....we were speaking about magnetic tape'. (lines 5,6, & 7)

What followed was an elaboration of the preparation.

(1) b-Introducing persons and topics e.g. 1a and 1b below:-

1a . 'I introduce you to Mr. AL-Attili, a colleague lecturer in the English Department'.(lines 1 & 2)

1b . 'Magnetic disk and magnetic disk drive is our lecture for today which is exactly opposite the magnetic tape when it comes to the direct or sequential access'. (lines 103, 104 & 105).

Both 1a and 1b may be called the beginning of the lecture.

(2) The middle of the lecture

2a. After the announcement of the topic of the lecture the lecturer proceeds on a lecture basis. The lecturer is well aware of his audience and tries to let them participate to guarantee understanding. This is clear in his asking questions and mentioning students' names. Even the visitor was asked to help in giving an Arabic meaning for the word 'beneath'.

- 'So before speaking about the disk individually, we are going to speak about the whole system. The magnetic disk, the magnetic disk unit and the magnetic disk drive' (lines 122-125)

- 'The disk unit...consists of many boxes or drums' (lines 133-134)

- 'The tape is long but with respect to the disk it is circle....' (circular) (lines 178-179)

2b. The development of the topic occurs on a gradual basis. e.g.

- 'Now...say the main job for the Magnetic Disk Drive, it is somehow like the magnetic tape drive'. (lines 161 - 162)

- 'One may ask...is the quantity of data recorded on track, say 150, the same as data recorded on track 1?'. (lines 216-217)

- 'A magnetic disk unit is a box or a group of boxes'. (line 245)

- 'I must mention that we said the magnetic disk consists of at least one read-and-write head... and so on'. (lines 250-52)

(3) The close of the topic. This is clear in two ways: Coming to an end in the topic itself and announcing the end and/or suggesting something else e.g. 3a and 3b.

3a. 'If we want to read and write data on a magnetic disk drive, only the first top and the last bottom surface do not, or it won't include any data...

Read-and-write heads cannot reach them. They are out of the reach of the arms....

Shall we write...copy them?' (lines 283-293)

3b. '...Anyway we are going to speak about this in full detail,....'. (lines 294-295)

3b. 'We'll carry on next lecture...and thank you again Mr. (AL-Attili)'.

The second part of this element relates to the information content. The lecturer has put this down in hand-written

preparation in topic headings. They are as follows:

(taken from the lecture in Appendix D2*)

- Topic : 'Magnetic Tape and Magnetic Disk'.
- Revision questions and answers - Examples and drawing -
'Everything in the computer is changed into binary which is 0's and 1's.'
- 'Data recorded on magnetic tapes cannot be seen by naked eye'.
- 'Magnetic Disk...a storing device used in I/O unit'.
- 'Disk is a thin metal platter....'
- 'Disk unit consists of many boxes.. but it may consist of at least one disk'.
- 'Disk drive consists of many arms called read-and-write heads..The heads read or write-record-data...' and
- Explanatory drawings.

The information content comes to an end when the lecturer announces the end by writing definitions on the blackboard and asking whether the students wanted to copy them and by his saying 'We'll carry on next lecture', and 'Thank you again, Mr....; forgive my mispronunciation'. (of the guest's surname).

The information content started from main ideas and ran into details about both 'Magnetic Tape' and 'Magnetic Disk' and related data.

The information content could well be presented in the following manner (prepared by the researcher):-

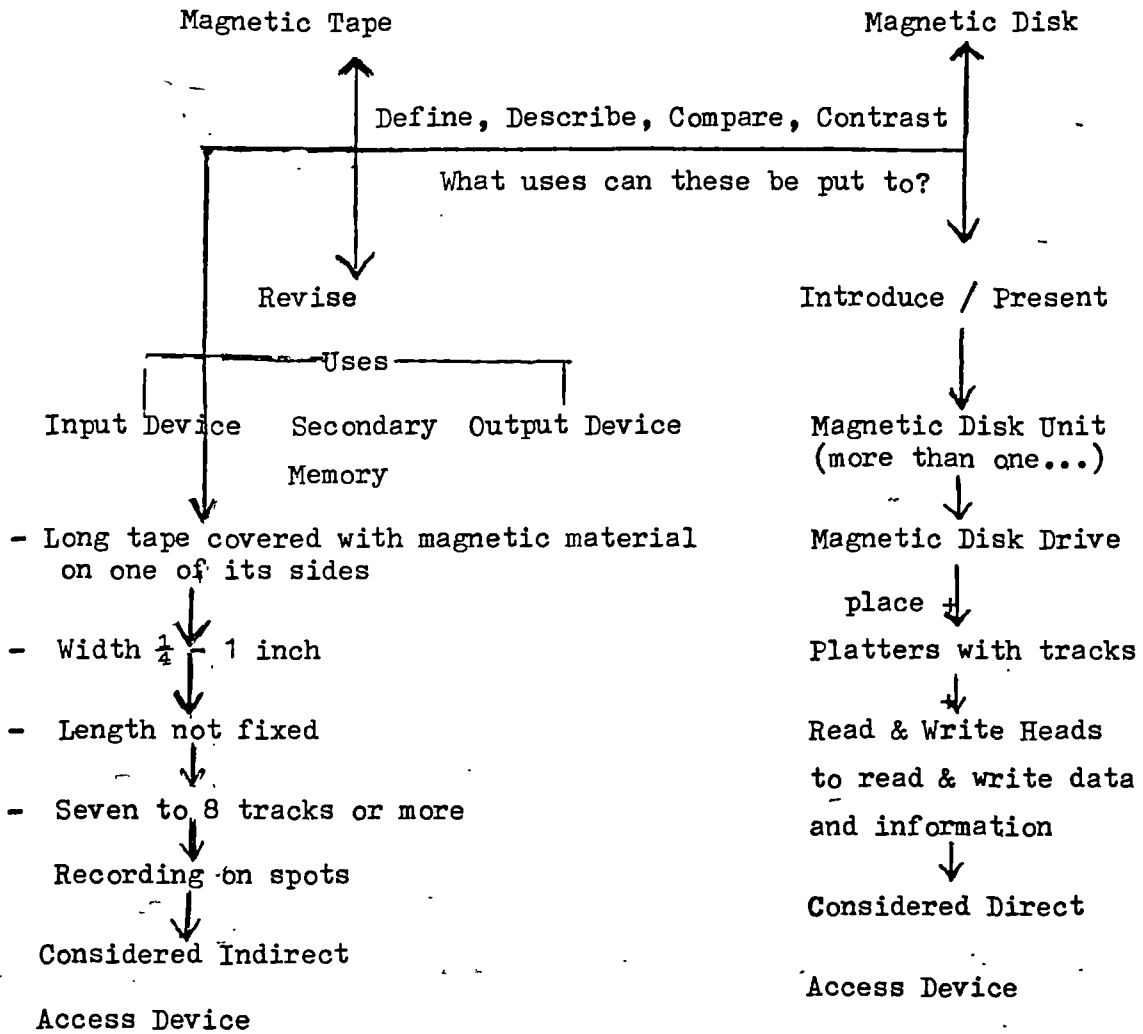

6.8.2.2 (ii) Macro-Markers

Macro-markers are usually divided into three types of metastatements, starters and high level information signals.

(1) Metastatements exist in D2 e.g. 1a ,1b & 1c below:-

1a 'There is (are) three main uses of the magnetic tape. Anybody can tell?' (lines 7 & 8)

1b.'Now..Anybody can explain the magnetic tape ... without looking at the notes?' (lines 25 & 26)

1c.'Looking to(at) the picture of a tape, we say it consists of 8 or 9 or 7 tracks...Of course, if we are recording in ASCII, we have 7 bits.... instead of 8; is that right or not?'. (lines 86-90)

(2) Starters e.g. 2a and 2b below:

2a.'Disk or magnetic disk belong/s to the direct access devices'. (lines 105 & 106)

2b.'One may ask...is the quantity of data recorded on track, say 150, the same as the data recorded on track 1?'. Abeer (?) (This is a student's name) (lines 216 & 217)

(3) High-level information signals e.g. 3a and 3b below

3a.'I must mention that we said the magnetic disk drive consists of at least one read-and-write head/s... which is in between the disks....'. (lines 250-252)

3b.'We are going to speak about the whole system: the magnetic disk, the magnetic disk unit and the magnetic disk drive' (lines 213-215)

6.8.2.3 (iii) Micro-Markers:

- (1) Temporal : 'As usual' (line 5), 'Now' (lines 25 & 161) and 'at the end' (line 62)
- (2) Causal : 'So' (line 47), 'since' (line 169) and 'if you want' (line 294)
- (3) Contrastive markers: 'But' (line 178) and 'exactly the opposite' (lines 238 and 239)
- (4) Relative emphasis markers : 'Actually' (Line 85) 'at least' (line 61) and 'of course' (line 66).
- (5) Framing markers : 'Right' (line 109), 'very good' (lines 219 & 236), 'OK' (line 40) and 'aha...aha' (line 44).

6.8.2.4 (iv) Function Realised in the Lecture

Eleven functions or more are realised in this lecture. They are as follows:

- (1) Introducing : a. persons and b. topics. e.g. 1a and 1b below:
 - 1a. 'I introduce you to Mr. AL-Attili. He is a lecturer in the English Department'.
 - 1b. 'Magnetic Disk and magnetic disk drive is our lecture for today'.
- (2) Back referring e.g. 2 below:
 2. 'In the last lecture we were speaking about magnetic tape'.
- (3) Explaining e.g. 3 below:
 3. 'It (The magnetic tape) is a long tape covered with a magnetic material from one of its sides and width

of the tape is usually $\frac{1}{4}$ - 1 inch and the length is not fixed'.

(4) Comparing e.g. 4a and 4b below:

4a. 'It (The magnetic tape) is like a tape of the tape recorder'.

4b. 'It (the magnetic disk) is like the album (of songs)'.

(5) Contrasting e.g. 5 below:

5. 'Secondary memory is not connected to the CPU. It is outside the CPU. For that reason the secondary storage is called external storage and the main memory is called the internal memory or internal storage'.

(6) Metastatements e.g. 6 below:

6. 'So before speaking about the disk individually, we are going to speak about the whole system: the magnetic disk, the magnetic disk unit and the magnetic disk drive'.

(7) Elaborating e.g. 7 below:

7. 'A disk unit consists of many boxes or drums. In each unit, there is at least one disk. It is very difficult to say how many disks we have in one disk drive. This...eh.. the arms and the read-and-write heads and the disks. They call them magnetic disk drive'.

(8) Defining e.g. 8a and 8b below:

8a. 'The address is track number, surface number and location'.

8b. 'A disk is a thin metal platter covered on both sides with magnetic recording material'.

(9) Analogy e.g. 9a and 9b below:-

9a. 'A drum is like that dust bin'.

9b. 'This is a head and there are arms like our arms'.

(10) Apologising e.g. 10 below:-

10. 'Thank you Mr. (AL-Attili); forgive my mispronunciation'.

(11) Concluding e.g. 11 below:-

11. 'We are going to speak about this (disk drives) in full detail, maybe in the next lecture'.

6.8.2.5 (v)

The recurrent structural and lexical items in this lecture:

(1) The use of the present simple tense which denotes factual information and the use of defining as a pedagogical strategy e.g. 1a and 1b below:-

1a. 'It,(the tape) is a sequential access device
'It belongs to a group called the sequential access device'.

1b. '(The) Disk unit consists of many boxes. It consists of many parts.....'.

(2) The use of the passive e.g. 2a and 2b below:

2a. '(The) Secondary memory is not connected to the CPU'.

2b. 'Data are recorded on this disk'.

(3) The use of conditionals e.g. 3a and 3b below:

3a. 'If we need any data, we can go directly into the data andcall it'.

3b. 'If there is more than one (disk), as can be seen, these disks are connected together'.

(4) The use of fillers which serve as initiation to get response and in turn receive feedback or evaluation e.g. 'aha', 'now', 'right'. This is accompanied with pauses as if asking for immediate response.

(5) The use of the informal question-answer, type .e.g. 5a and 5b below:-

5a. 'Teacher: Anybody can tell....What does it mean?

Direct Access Device.....Come, Adeeba'.

5b. 'How data are recorded on a magnetic tape?

Yes...again, Eiman' (a student).

(How are data recorded on a magnetic tape?)

(6) The use of Arabic - translation - to explain and to save time while explaining. e.g. 6a and 6b below:

6a. 'Alustuwanat' for Albums

6b. 'Almidhmar' for Athletics ground'

'Taht' for under or beneath.

(7) The use of deliberate repetition as a didactic strategy for reinforcement of topic and idea. e.g.

7. 'What is the magnetic tape ?'

- 'It is a long tape with magnetic material on one of its sides'

- 'Data are recorded on a magnetic tape'.

- 'It consists of seven....or nine tracks'.

- 'On each inch of the tape, we can record thousands of characters and thousands of bits...'

-'Looking (to) at the tape, we say it consists of...
8 or 9 or 7 tracks'.

- (8) Concentration on content in an informal style when
explaining but trying to be accurate when it comes
to defining. e.g. '

-'Disk is a thin metal platter'....

-'It (the magnetic disk) is one of the important
devices in storing data'.

-'They (the top surfaces of disk units) are out of reach
of the arms. Due to that, we cannot store any information
or data and the same for the one beneath'.

- (9) The lexical items recurrent in this lecture relate to
the content which is very important for the computer
scientists and their computer science teacher. The
organisational and structural form of the lecture should
be important for all, the computer scientists, their
computer science teacher and for their teacher of English.
The former two are more interested in the message content
than in the means which is mostly linguistic and
communication-based, hence its importance to the ESP
teacher. The ESP teacher, be he a classroom teacher or
a course designer, should pay more attention to the means
and strategies of getting the message to the computer
scientists simply because others take care of the accuracy
of the content. They are more knowledgeable than he is
in that specialisation.

The lexical items are the information carriers. If

they are adequately chosen from the course of a lecture, they could easily refer to the topic or content. Take, as an example, the following lexical items that occurred in, this D2 lecture: magnetic tape, i/o device, secondary memory, $\frac{1}{4}$ - 1 inches, magnetic spots, 7-8 tracks, recording on spots.

This may form the core information concerning the tape but the following may epitomise that of the magnetic disk unit: magnetic disks, thin platters, tracks, read-write-heads, record or read information, and direct access device. With the previous condensed lexical information we could epitomise the lecture. But when we want to get it back to its normal state as a lecture, we do need much more than that and therein lies the responsibility of the teacher. The suitable course design based on the broad needs defended in this thesis tackle this problem and make it easy for the ESP teacher to successfully play his role. That would be based on the right and suitable selection of skills and strategies that should be included in an ESP course in response to the broad needs.

6.8.3 Almahmeed's Synopsis

The synopsis of this lecture will be treated as it is in the same way other lectures were treated with reference to the points in section 6.4 of this Chapter.

6.8.3.1 The overall organisation

This lecture - Appendix D3 - has been prepared by the lecturer

as a synopsis. It simply presents a drawing of a Hypothetical Computer with the names of components 'A-I' as in the synopsis. The lecturer had also prepared a brief account of 'The Control Gates', 'Gating Information', 'The Data Bus' and 'The Instruction Format'.

The parts of 'A Hypothetical Computer' are put together by the lecturer in a logical manner; the arrangement is not according to the drawing. If the student wanted to take notes, he would do what his teacher had done. He would draw the 'Hypothetical Computer' and jot down the definitions of its parts for further reference. So we can say the lecture is in both linear and nonlinear texts as retained necessary by the lecturer.

The lecturer goes directly into the topic, defines the parts, classifies them, describes them and elaborates on logical processes through 'Gating Signals' and 'Instruction Formats'.

The beginning is that of 'Hypothetical Computer'. The middle is the definition, classification, description, whereas the end or close is in the 'Control Gates' or logical processes. (See the diagram the first page of D3. The development of the topic is a matter of sequencing arising from the operation the computer is executing.

As we can see there are no revision questions though the lecturer had started the lecture by doing so. The lecturer announced his intention to stop and asked the students who did not or could not copy the definitions to do so. That marked the close.

6.8.3.2 & 6.8.3.3

The present synopsis does not contain macro or micro-markers but the original lecture did. The markers used are similar to those used by Sartawi and Almukbil.

Regarding the high-level information signals these can be easily pointed out. They are the sub-headings used in the diagram for computer parts or operations e.g.

'From the above figure:

A computer consists of the following important units:

a,b,c,d,e,f,g,h, and I plus 'The Control Gates', 'The Data Bus' and 'The Instruction Format'.

6.8.3.4 Functions Realised in The Lecture:

The following functions are realised in the lecture:

1. Defining e.g. 1 below:

1.'A register is a high speed device capable of storing a specified amount of data or of storing intermittent results during processing'.

2. Classifying e.g. 2a and 2b below:

2a.'Address Register is the unit whose function is to hold the address of a specified word in the main memory'.

2b.'An Instruction Register (I.R.) is the unit which holds the instruction currently to be obeyed. This register is connected to (with) the function decoder in order that the bits which represent the desired function will produce appropriate signals to call into action those parts of the arithmetic unit necessary for executing the function'.

3. Summarising e.g. 3 below which presents the least minimum information content to be mentioned:

3. 'An arithmetic and logic unit (ALU) is used to perform basic arithmetic operations and the various logical functions'.

This may be considered 'defining' but here and in this context. Summarising is more prominent.

4. Explaining e.g. 4 below:

4. 'Control Gates... by means of which the streams of bits may be directed to correct destinations. Such gating may be performed by means of AND Gates through which the information may or may not be allowed to pass. The following figure shows how gating may be accomplished.

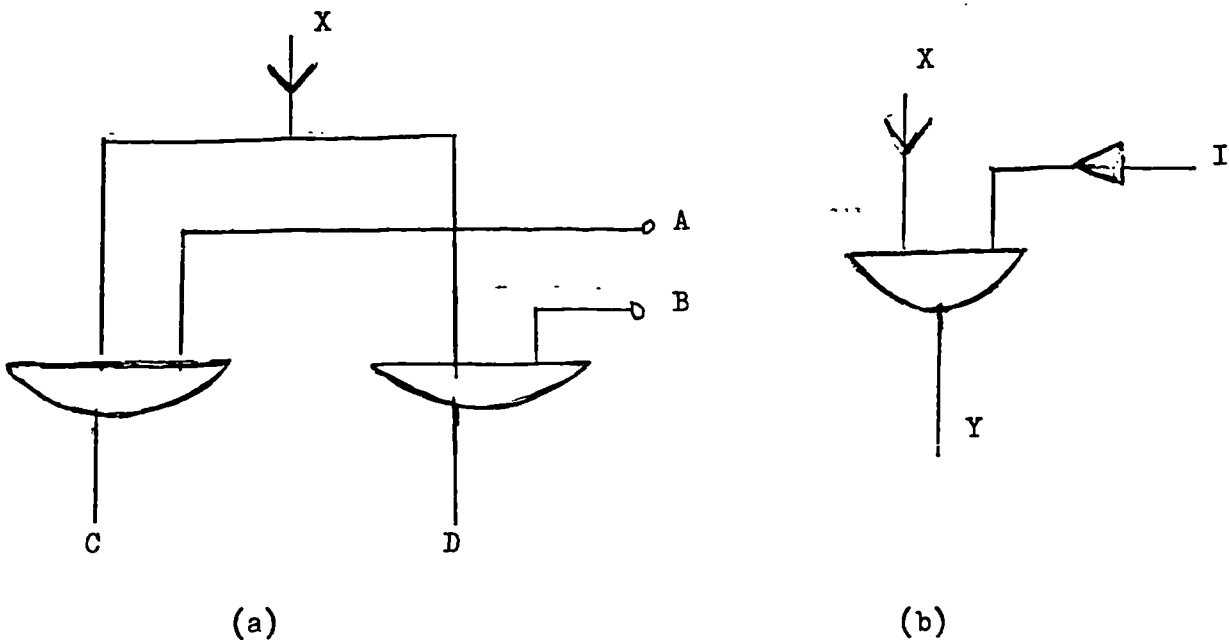

In (a) information may be diverted from the source x to either C or D'. (The explanation goes on).

5. Exemplifying. e.g. the figure (a) above which gives an example of how 'Control Gates' in a computer perform their work.

The cause for the limited range of functions is that of the lecture being in a synopsis form. In practice, the functions that were included were more numerous than the ones the researcher included but he could not exemplify due to the abrupt breakdown while the recording was going on.

6.8.3.5 The recurrent structural and lexical items in the lecture.

- (1) The use of the present simple tense due to factual and process-describing information e.g. 1a and 1b and 1c.

1a. 'The computer consists of the following important units'.

1b. 'An Instruction Register (IR) holds the instruction, currently to be obeyed....'.

1c. 'A program counter (P.C.) enables the computer to proceed through a program from one instruction to the next'.

- (2) The use of the passive e.g. 2a below:

2a. 'This register (I.R.) is connected to the function decoder....'

- (3) 'A peripheral interface (P.I.) is the unit which enables information into and out of the machine to be connected to a range of input and output devices, such as electronic typewriters'.

- (4) The use of cohesive devices marking reference 'which', embedding (and), and 'such as' as in the previous example.

- (5) Minimised use of micro-markers since this is a condensed form of a lecture.

- (6) The use of modal "may" especially in the last two pages of Appendix D3 e.g.
'may be directed', 'may be performed', 'may or may not be allowed', 'may be on', 'may have', 'may be interrupted', 'may be used', and 'may represent'.
- (7) Concentration on content and diagrams, information content and explanatory and exemplificatory diagrams.
- (8) The repetition of headings and sub-division. This can be seen in the synopsis and the diagram.
- (9) The tendency to use acronyms or abbreviated forms, e.g. 'ALU' for Arithmetic Logic Unit, 'P.C' for Program Counter and 'I.R.' for instruction register.

6.9 The Contribution of the analysis of classroom lectures and classroom discourse to a broad needs analysis.

Classroom lectures and classroom discourse can and should be taken into consideration when setting out on the task of needs analysis for an ESP course design for KBI computer science students. The researcher supports this view and has been defending it through out the thesis. He argued the theoretical aspects in ESP in Chapter Two; criticised the ELT materials used in KBI in Chapter Three, took the teachers' views into account in the questionnaires in Chapter Four, performed an analysis of computer science texts in Chapter Five and has analysed classroom lectures in Chapter Six. This was done in order to establish a documented and systematically based evidence for the inclusion of the results of classroom lecture analysis in the broad needs analysis he is defending.

The results of the analysis of classroom lectures have shown many features.

6.9.1 Features of the English Language used in oral communication in KBI computer science lectures

Having carried out the analysis of the oral discourse of computer science lectures in KBI, the researcher has gleaned the following categories of features as characteristic of the oral discourse.

(a) Functional features:

Computer science lecturers utilise various functions while lecturing or orally communicating with their students. The functions utilised throughout the three sample lectures were, to mention some, introducing, defining, naming, comparing, contrasting, explaining, exemplifying, classifying, elaborating, summarising, analogy, metastatements, and concluding. In fact more than fourteen functions were manipulated. These functions could well form a component of the ESP course because it stems from the realia and forms an evidenced basis for need analysis.

(b) Linguistic and sociolinguistic features. Many linguistic features were utilised in the lectures such as:

1. The use of the present simple for two reasons of defining and giving factual information.
2. The use of conditionals to help in describing changes in states and operations.
3. The use of the passive mostly to describe operations.
4. The use of modals to vary effect as needed in the discourse.
5. The use of gerunds as a kind of variation by using it

instead of names sometimes and to replace verbs at other times.

6. The use of complex sentences for expounding definitions and ideas.
7. The exploitation of 'key' and 'tone' to produce the effect aimed at.
8. The utilisation of certain cohesive markers to relate sentences to each other.

The aforementioned aspects should be taken into account when dealing with the needs of learners in case of intending to design a new course for them since they stem from the actual classroom discourse.

The researcher acknowledges the other linguistic aspects of the oral discourse: take, for example:

1. Disjointed sentences,
2. Discontinuity of sentences, and
3. The use of less structured language.

There should be a sort of orientation towards these aspects by the ESP course designer due to their forming a part of the real discourse and being reached at within the framework of broad needs analysis.

Another sociolinguistic aspect e.g. introducing guests, occurred during the lectures. This aspect could well be taken into consideration for needs analysis purposes. This side exemplifies the sociolinguistic need of ESP students.

(c) Discoursal Features

Lectures were treated as oral discourse. When analysed for their discoursal features, the researcher considered them as communicative events concentrating on a topic. The topic has a beginning, a middle and a close. The unity of the parts of a discourse is achieved through intersentential and intrasentential devices the product of which is considered a coherent discourse. In oral discourse macro and micro-markers contribute to the unity of the discourse and to making it a meaningful whole.

When pointed out such features of discourse could be manipulated as they form a part of the subject-specific discourse and so contribute to the broad needs of ESP Computer Science students.

(d) Communicative Features.

The lecture or oral discourse when written down is considered a record of speech event or as Brown & Yule (1983) call it "an orthographic record of a communicative event". Computer science lecturers' aim was to communicate something to their students about the topic discussed. In order for the KBI computer science students to understand the discourse, KBI lecturers used linguistic, functional, discoursal and paralinguistic tools most of whose features have been mentioned before. So when ESP courses are to be designed, they should utilise such features as they have come into being as a result of analysing their communicative events.

Such features are to be taken into account when dealing with KBI computer science students' needs. Translation is approved of for quicker communication which should also be taken into account when needs are analysed.

(e) Disciplinary Features

These features are exemplified in the subject matter - computer science. Lecturers usually follow certain self-made or recommended approaches of introducing one topic at a time. This includes topic introduction, development and a close. For didactic or pedagogical purposes, strategies like repetition are usually utilised for emphasis or as built-in revision system of the information content. The starting point in a lecture is a revision of some previous issue and the rest may be presentation, practice and production or the three P's. The close may constitute a call or suggestion for more or what is called expansion. All that is carried out in paragraphs based on the sentence or the utterance which constitute basic units of oral discourse.

These disciplinary features e.g. one topic at a time could contribute to the ESP course design and the needs analysis of ESP computer science students' which constitute contributions to their real needs.

(f) Paralinguistic Features

Kinetic movements e.g. pointing at things, bodily movements, diagrams or demonstrations have been observed. One lecturer showed a cross-section of the computer science

topic which was 'The Magnetic Disk'. These features should be taken into account when needs analysis is viewed in broad terms as the researcher advocates.

(g) Organisational Features.

The attendance sheet as well as official announcements take place and time to be carried out. Though they reduce the time meant for contact, they are seen worthy of referring to when needs analysis is determined.

(h) Extraneous Features

The range of extraneous features that affected the discourse of lectures, is wide. Interference takes place e.g. noises, squeaks and moving chairs hamper communication.

Distraction may take place due to traffic flow or late students coming into the classroom. The physical, the intellectual and the psychological state of students may hamper communication. Such features the researcher believes students should not be orientated towards though they occurred either within or outside the classroom and affected the flow of discourse. They should not be given any sort of concession or consideration.

The previously mentioned features are of classroom lectures. Having identified them takes us back to the fact that the computer science students' needs are to benefit from what happens as it is a part of the broad needs analysis the researcher is defending.

C H A P T E R _ S E V E N

CONCLUDING THE RESEARCH

7.0 The Problem of Needs Surveyed

The need for English Language for both EOP and EAP courses is unmistakably indicated by the research completed here. The need exists for English in listening to lectures, following practicals, reading texts, handouts, instructions and correspondence and in writing down notes, papers and examinations. Similar need exists for English for Occupational Purposes as well. This need was ascertained through the responses to questions 28,29 and 30 in the employers' questionnaire, questions 27,28 and 30 in the teachers' questionnaire and graduates' questionnaire whose results are tabulated in Chapter Four.

Within KBI, ESP English is also needed for communication with computer science lecturers, computer personnel in seminars and with teachers of English. The English Language is being demanded for communication purposes during study and for similar communication with native speakers and students of different nationalities if studying in English medium universities. As a result of such communication the need for social English has arisen for need to talk about oneself, interests, likes, dislikes and preferences. The KBI situation is partly like this.

With the need for EOP, EAP or, in general, ESP established, the researcher agrees with Schutz, N.W. and Derwig, B.L. (1981) as to their eight essential steps to needs analysis. These steps include:-

(a) Defining the Purpose.

In this case the purpose is the execution of a sound needs analysis for ESP courses for KBI Computer Scientists.

(b) Delimiting the target population.

In this case the population is of KBI computer scientists, teachers and employers.

(c) Delimiting the parameters of investigation.

The parameters are the theoretical survey, questionnaires, written and oral computer discourse analysis and a critical appreciation of ELT materials used in KBI.

(d) Selecting the information gathering instruments.

(e) Collection of data.

In this case the data was collected through questionnaires and/or constructed interviews and through analysis of the oral and written computer science texts.

(f) Analysis of the results.

In this case the analysis of the results of questionnaires and/or constructed interviews were dealt with and analysed manually to get to know such general trends, as there were, in order to base the definition of needs on systematically documented bases. The results of analyses, in this case, we grouped under the five categories in section 6.4 of the last chapter.

(g) Interpretation of the results.

In this case many features were taken into consideration. e.g. the results support our views regarding the need for needs analysis for ESP courses etc.

(h) Critique of the project.

In this case it is research that aims at establishing sound bases for needs analysis to be taken into account prior to designing any ESP courses for KBI computer scientists. The rest of this will be spelled out in this Chapter.

These steps should be acknowledged as the right ones for the execution of such research, the frequent interpretation of target population and what constitutes adequate parameters of investigation of students' expressed needs, while in this case, we have a triumvirate of views, concerning population and the language demands of the students' academic study.

The term triumvirate has been adopted throughout the thesis to refer to the views of employers, teachers and graduates.

7.1 The Purpose

The researcher has already defined his purpose regarding the problem of needs analysis. He supports and defends a broad type of researched needs analysis pertaining to students' needs but with the views of the triumvirate, the researcher has treated as his categories of sample population, taken into account. The views of the triumvirate form an integrative pragmatic whole that could be described as an indispensable solid basis for any researched needs ESP course design.

This result has been reached at through the questionnaires whose results have been included in Chapter Four.

Greenwood (1981:249) describes some but not all the prerequisites of a course design. The elements he included are 'learners', 'purposes', 'ages', 'teachers' and 'levels of English'. He did not refer to employers' views. His target could well be considered as aiming at GPE courses which, then, do not necessitate calling for employers' views.

He wrote:-

"Knowing who the learners are, the teacher is able to plan the course in the light of their ages, purposes in learning and levels of English. With such information available the teacher is able to determine the materials and the learning activities, the textbook, the audiovisual aids etc".

The researcher's point of view is that the teacher will, in the above mentioned case, produce materials that would not match the target situation activities and views of employers regarding communication skills.

Greenwood's view is similar to that of Van EK (1976,1977) concerning directing needs analysis to the interests of large classes of learners rather than individual students. More emphasis should be laid on all the views of the parties involved, not separately but with a view to synthesising all for the learners' interest.

Rivers, W. (1983:133) carries the argument a bit further. She does not support the idea of giving the learners what we think they need, meaning preconceptions without 'balance'. She rightly put it:-

"As in all marketing research, we must not merely identify what we think our customers need, but also what they want (that is what they feel they need).As educators, we must provide for a balance between these two if students are to be motivated to learn what we offer".

The researcher supports the idea of researched needs based on the triumvirate of opinions, not only the abovementioned two. This, as a corollary, would give optimal output.

We agree with Trim (1980:vii) that:

"Course planning must be based not only on the need... of the learner, but must take into account the needs of the social group to which he belongs, the institutions providing the educational framework and the social institutions that provide the resources...."

The researcher has been arguing all through from the Second to the Sixth chapter of the thesis that researched needs basis is an essential element in the production of acceptable and appropriate ESP courses. The type of appropriate courses that would be flexible and allow concessions for feedback and development are the courses we are defending in Trim's words:-

"A well-defined programme must have the flexibility to respond to changes in the learner, the teachers and the circumstances in which they are working". (Op Cit)

Schutz and Derwig are well aware of the courses and their specialised nature. Such course offerings should go beyond the general-type courses or else suffer the result of being courses which were produced for an 'audience which does not exist'.

KBI ELT materials which include some EAP courses that have not been selected or prepared with the triumvirate, do not, as they are, harmonise with the needs analysis criteria the researcher has been advocating and defending. What really exists is a sort of patch work whose relevance cannot be defended. This can be emphasised with reference to the theoretical views examined in Chapter Two, or the functional, communicative, discursal, organisational and disciplinary

features of the discourse in Chapters Five and Six. The criteria applied in Chapter Three has marked them not suitable for instruction and as have not been produced according to needs.

Having closely and accurately studied the KBI situation for more than a decade now, which is the life span of KBI, the researcher has come out with the following conclusions regarding the problem of needs and the issues involved in designing ESP courses for KBI computer science students in particular and for the rest of the students of different specialisations in general.

7.2 Bases for ESP Courses

It is the prime concern of this thesis to argue from the basis of the collected data that an appropriate approach to needs analysis for EOP courses should incorporate the following steps:

- (a) Researched needs analysis should be carried out prior to developing any new ESP courses.
- (b) The needs analysis process should take into account the triumvirate views or a suitable acceptable compromise. This was carried out by the researcher on three sample populations of graduates/students, teachers and employers in Chapter Four.
- (c) A needs analysis should focus on both the present and future needs of the learners. Present needs should encompass job purposes or target situations and both should consider pragmatic purposes. Various sections of the questionnaire replicate these needs especially the open-ended last question.
- (d) In order for the needs to be well-defined, they should

be determined after executing the following steps:

- (i) Studying and performing a critical survey of the existing relevant literature so as to be conversant in the subject area. This has been carried out in Chapter Two.
- (ii) Administering questionnaires and/or constructed interviews for eliciting information from students, teachers and employers, as in Chapter Four.
- (iii) Executing an analysis of texts of the specific discipline aimed at getting to know the characteristic features of the specific discourse such as the functional, organisational, linguistic, communicative and disciplinary features that exist in the discipline. Chapter Five of this Thesis presents the results of such an analysis.
- (iv) Executing analysis of classroom discourse whose results should be appropriately utilised for inclusion when setting out on the task of course design. This was carried out in Chapter Six.

Data was gathered during the research through many channels like the questionnaire, the result of text analysis and classroom discourse analysis. Another source of data was the theoretical treatment and discussion of issues relating to subject-specificity, authenticity, relevance and suitability of ESP teaching materials. From this collected data, we got to know the different indications of language needs of the groups concerned in the production of such data. e.g. The teachers prefer to rearrange the skills as reading, writing, speaking and listening while the students or graduates and the employers give

priority to speaking over all others. Most of the teachers said English was useful; 92% did so while the rest did not agree to that. The analyses of texts showed characteristic features of written very carefully structured discourse meanwhile the classroom discourse analyses gave a different picture of classroom interactive discourse.

The researcher believes that without such broad needs analysis as the one he supports, there will be failure to identify crucial elements within the learners' range of needs. This conclusion is based upon three supportive areas:

- (1) The body of the thesis
- (2) Extrapolations from the issues discussed and the results obtained from analyses and discussions of relevant issues.
- (3) The researcher's practical experience in the field of ELT/ESP teaching.

Although the prime concern of the Thesis has been to establish an adequate basis for the definition of needs, it is also relevant and useful for the interpretation of the research to move into the practical areas of course content, methodology and teacher-training. With a brief discussion of these areas, the researcher will extrapolate from the body of discussion and data what seem to be the implications for these practical areas. Clearly these practical areas need to be dealt with adequately in order for a soundly-established needs analysis to be put to effective use in the ESP classroom. The researcher has dealt with these areas and would like to add that good needs analysis does not mean or guarantee the execution of good ESP courses.

7.3 Content

The issues of needs analysis lead us then to the issue of content and quality of materials. The researcher has come out with the following regarding content and the nature and quality of materials to be used in KBI, ELT and ESP courses.

- (a) All ESP courses should be preceded by an introductory GPE course for all specialisations in KBI.
- (b) Materials should be subject-specific in content and in discursal and other features. They should represent the discourse register of the variety of language used in the discipline.
- (c) These materials should respond to present needs and be adaptable regarding recent developments and expected needs.
- (d) The needs of the KBI students are not those of subject-specific content only. Content should include social, cultural and broad needs of KBI students, not only their subject-specific, functional or linguistic content.

7.4 Methodology

- (a) The methodology accepted by the majority of the sample population is the communicative methodology which, in essence, emphasises communication and also manipulates the specific needs of the students.
- (b) This communicative methodology should aim at the development of fluency as well as accuracy and not on fluency on behalf of accuracy. Minor errors or mistakes should not impede communication especially in early stages.

- (c) A balance between both fluency and accuracy strategies and techniques should be utilised in the ESP course design.
- (d) The idea of balance between fluency and accuracy necessitates eclecticism in methodology at times. Thus eclecticism may serve as a therapeutic technique. We mean the teacher can refer to a structural issue if he feels his students are not good at it and that obstructs good communication on their part. The idea of balance necessitates the need for minimum grammatical or systematic knowledge of the rules of use and rules of grammar for effective error-free and acceptable communication.

7.5 Other Pedagogical Issues

Certain Pedagogical issues should be taken into account in ESP course design.

- (a) The first is subject-specificity which encourages and motivates learners.
- (b) Progression or the ordering of language items by their relative importance. This may be achieved through sequencing as well.
- (c) Progression calls for interrelations between units of a certain course and among courses for the same specialisation.
- (d) Skills should be utilised, in the design of a course, according to needs analysis results. They should or could be subdivided into different skills which may be emphasised according to ESP students' purpose.

7.6 Teacher-Training

The above mentioned issues of specificity, progression, interrelations, utilisation of skills, require highly-qualified and properly-trained teachers to perform their roles efficiently.

Suitable and relevant teacher-training leads to the success of all the parties concerned in the execution of an ESP course or program. If the teachers are interested in the ESP content, the teacher's book or teaching notes may be enough to orientate them towards the course and any areas of possible misunderstanding. If not a carefully-prepared training course would be suitable for arming teachers with the content, purpose and most importantly the know-how they should acquire for teaching the course.

Teacher's should be briefed of the content though it should not constitute their main target. Teacher-training should be based on:-

- (a) supplying trainees with the communication needs for playing an effective role.
- (b) The communication needs should exploit the linguistic competence of the learners besides paralinguistic cues and shared knowledge.

Through training based on needs and exploiting linguistic competence, the training course should have, as its target, improving the communicative performance of the learners especially in the final stages through the insistence on the presentation of language in meaningful situations or relevant contexts. In Sinclair's words at the Second Regional ESP Conference held in Iran (1977:12) other ESP teachers should not compete with the subject-specific teacher.

"The ESP teacher is not masquerading as a specialist ⁱⁿ in

another subject. He is exercising his professional skills in an area where the attention is more on language fluency than on conceptual advance, and the subject area is supposed to be familiar to the student".

7.7 Conclusion

The discussion so far and the evidence from the collected data makes it possible to argue that:-

- (a) ELT materials that were used or taught in KBI did not service or meet the students' needs, neither in the ^{cr&s} common courses nor in the subject-specific ones.

In Attia's (1985:264) words:

"Courses are unsuitable, do not fit the specific communicative requirements of a specific group of learners in the target world".

The materials mentioned and criticised in Chapter Three should be rejected accordingly and replaced with materials commensurate with our findings.

- (b) The materials currently used have not been adopted as a result of carrying out the needs analysis necessary in such cases. Views of the triumvirate have not been taken into account nor has there been any co-ordination of their views in order to establish an effective compromise.
- (c) The materials are not subject-specific and so do not represent the target situation the computer scientists will be put in. This leads to frustration and lack of motivation on the part of the students who are unable to utilise them in solving their study problems. Thus they were not 'capable of generating useful language work' according to Hutchinson and Waters. By subject-specificity, the researcher means both the specific contents and the skills relating to

the specific-content materials especially the ones peculiar to it.

- (d) Within presently used, supposedly ESP, materials, there are cases of subject-specific content which does not suit the intellectual standard of the students and so causes them to lose interest in the course.

Relating to the previous conclusion is the fact that some units e.g. in 'Old English 201' are indigestible and so the students could not cope with them.

- (e) The Materials have not been properly 'doctored' to the purpose and so were not motivating or interesting to the students.

- (f) The materials do not exploit 'translation' which was found helpful for ESP students. In Mackay's (1981:141) words:-

"Despite the climate of disapproval surrounding the use of translation as a learning strategy, we felt that this kind of exercise was justified. After all, although the students had to read in English, the information gained had to be employed in Spanish (Arabic) integrated into their existing knowledge in Spanish (Arabic)".

7.8 Suggestions For Further Research

The researcher after performing what he believes to be the right steps in the field of ESP needs analysis for the design of appropriate ESP courses for KBI computer science students suggests that:-

- (a) Relevant and innovative research needs to be done in areas where the needs are blurred, are not appropriately dealt with or are completely ignored.

The result is inappropriate course materials with needs of the learner or learner stereotype overlooked. Such practices

are detrimental to the interests of the parties involved in the teaching-learning-employment processes.

- (b) The researcher also calls for the co-operation of all parties concerned in the needs analysis process so as to guarantee an appropriate and sound basis for the design of ESP courses.
- (c) The researcher suggests locally-made scientifically-based ESP courses to be produced by natives who would always take the psychological setting and the communication needs into account paying respectful attention to features of the cultural context.
- (d) The researcher calls for sufficient informality in classroom conditions to let students behave in a communicative way interacting and co-operating as naturally as possible. This is a necessary condition for communicative methods to be effectively used.

B I B L I O G R A P H Y

- Abbot, G. and Wingard, P. (eds) The Teaching of English as A Foreign Language 1981 - Collins
- Abbot, G. Training Teachers of EST : Avoiding Othodoxy Vol.2. No. 1. ESP Journal 1983
- Allen, J and Widdowson, H.G. Teaching the Communicative Use of English Mackay, R and Mountford, A. (eds) English For Specific Purposes 1978 Longman
- Allright, J and Allright, R. An Approach to the Teaching of Medical English. Susan Holden (ed) English for Specific Purposes 1977 Modern English Publications.
- Almanakh Newsletter of the Language Centre, Kuwait University - Kuwait.
- Andrew, S. The Effect of Arabicisation On the Role of Service English, ESP in The Arab World 1984. Swales, J and Mustafa, H. (eds) LSU, The University of Aston, Birmingham, The United Kingdom
- Anwar, M.S. Discourse Analysis: A Linguistic and Literary Perspective - Proceedings of the First National Symposium On Language Teaching, Sponsored By the Language Centre, University of Kuwait - Kuwait - May 1985.
- Attia, M.H. A Critical Analysis of ESP Courses at Kuwait Technical and Vocational Institutes with Special Reference to Kuwait Business Institute - Unpublished Ph.D Thesis 1985 - University College - Cardiff. The United Kingdom.
- Austin, D & Crosfield, T. English for Nurses. 1976 Longman
- Austin, J. How to Do Things with Words 1962 Clarendon Press
- Bates, M & Dudley-Evans, T. Nucleus General Science 1981 Teacher's Book - Longman
- Beeching, K. Authentic Materials, Vol.20 No.1 1983 British Journal of Language Teaching.
- Beedham, C & Bloor, M. English for Computer Science and The Realisation of Communicative Functions - 1980 - Language Studies Unit - University of Aston - Birmingham, The United Kingdom.

- Blackie, D.J. Service English for Students of Science and Technology 1976 FORUM
- Bloor, M. Identifying the Components of a Language Syllabus : A Problem for Designers of Courses In ESP or Communication Studies - ELT Document 117 Common Ground: Shared Interests in ESP and Communication Studies - Williams, R. Swales, J and Kirkman J (eds) 1984. The British Council and Pergamon Press
- Bohl, M. Information Processing. Science Research Associates - SRA - Inc. Fourth Edition 1971-1984 Chicago
- Bonnyrust, W. Parallel and Alternative Education Report Submitted to the Ministry of Education, 1979 Kuwait.
- Bousquet, M & Mackay, R. LSP Curriculum Development - Languages for Specific Purposes - Mackay, R and Palmer, J (eds) 1981 Newbury House
- Breen, M & Candlin, C. The Essentials of A Communicative Curriculum in Language Teaching - Applied Linguistics Vol. 1 No.2 1980
- The British Council ELT Documents - London.
- English for Specific Purposes - An International Seminar Bogota - 1977 A Special Issue
 - English for Specific Purposes - ELT 101 - 1978
 - Team Teaching in ESP ELT 106 - 1980
 - The University of Malay ESP Project - A Special Issue 1980
 - The ESP Teacher ELT 112 1981
- Broughton et al Teaching English as A Foreign Language 1978 Routledge & Keegan Paul
- Brown, G & Yule, G. Discourse Analysis 1983 Cambridge University Press
- Brumfit, C. Common Sense About ESP - Holden, S (ed) English for Specific Purposes - 1977 Modern English Publications.
- Brumfit, C & Johnson, K (eds) The Communicative Approach to Language Teaching 1979 Oxford University Press.
- Brumfit, C Ideology Communication and Learning To Use English Vol. 34 No.3. 1980 ELT Journal
- Brumfit, C. Problems & Principles in English Teaching 1980 Pergamon Institute - Oxford.

- Brumfit, C (ed) English for International Communication 1982
Pergamon Institute of English
- Brumfit, C (ed) General English Syllabus Design 1984.
The British Council in association with
Pergamon
- Candlin, Burton, Leather & Woods Designing Modular Materials - English for Academic and Technical Purposes - Selinker, Tarone & Hanzeli (eds) 1981 Newbury House
- Carroll, B. Testing Communicative Performance 1980 Pergamon
- Chamberlain, R & Flanagan, M. Developing A Flexible ESP Programme Design 1978 - The British Council Archives.
- Chamberlain, R The SP of the E - ELT Document 106
Team Teaching in ESP - 1980 The British Council
- Chambers, F. A Re-evaluation of Needs Analysis in ESP-
1980 ESP Journal
- Chambers, F & McDonough, J How Many People? Opposing Views on the Function and Preparation of the ESP Teacher-ELT Document 112. The ESP Teacher - 1981 - The British Council.
- Chambers, F. Escaping From A Neutral Language - Modern Languages Vol.62 No.3. 1981
- Chambers, R. & Longman, M. Training in Skills - Communication Skills and The Needs of People In Industry 1982
A CRAC Publication - Hobson Press - Cambridge.
The United Kingdom.
- Chomsky, N. Aspects of the Theory of Syntax 1965
Cambridge, Mass : MIT Press
- Chaudron, C. & Richards, J. The Effect of Discourse Markers on The Comprehension of Lectures. Applied Linguistics Vol.7. No.2. 1986
- Cleary, J. The Use of Video-Tape Recordings on the Communication Skills - KAAU Engineering Project ELT Documents 101. English for Specific Purposes 1978. The British Council.
- Coefsey, B. English for Academic Purposes - Mimeo 1980
RELC, Singapore.
- Corder, S.P. Introducing Applied Linguistics, 1973 Penguin
- Corder, S.P. Error Analysis and Interlanguage 1981, OUP
- Coulthard, M. An Introduction to Discourse Analysis 1977
Longman.

- Crocker, T. Scenes of Endless Science - ELT Document 112
The ESP Teacher 1981. The British Council.
London.
- Crocker, T. Methods as Input and Product of LSP Course
Design. ESP in The Arab World - Swales, J &
Mustafa, H. (eds) LSU, Aston University,
Birmingham. The United Kingdom.
- Crofts, J.N. Subjects and Objects in ESP Teaching Materials
English for Academic and Technical Purposes.
Selinker, Tarone & Hanzeli (eds) 1981.
Newbury House.
- Crystal, D and Davy Advanced Conversational English 1975. Longman.
- Cunningsworth, A. Evaluating and Selecting Teaching Materials
1984. Heinemann Educational Books.
- Davies, F and Greene, T. Reading for Learning In the Sciences 1984. O & E
- Deeson, E. BBC Micro in Education 1983, Shiva Publishing Ltd
- Doughty, P. Introduction to Learning How To Mean 1975
Halliday, K.A.K. Edward Arnold.
- Driven, R. State of The Art, Language Teaching Abstracts
Vol.18. No.1. Jan. 1985.
- Drobnic, K. Teaching Conceptual Paragraphs in EST Courses,
A Practical Technique, ESPMENA Bulletin 10/
1978.
- Drobnic, K. 38 ESP Textbook Reviews - Mimeo 1978. Oregon
State University.
- Dudley-Evans, T. Team-Teaching Approach to Lecture Comprehension
For Overseas Students in The Teaching of
Listening Comprehension. ELT Documents Special
1981. The British Council.
- Dulay, H. Burt, M.& Krashen, S. Language Two 1982. OUP
- Early, P.B. The ESP Teacher's Role - ELT Document 112. 1981
The ESP Teacher - The British Council.
- Ellis, R. Classroom Interaction and Its Relation to
Second Language Learning, RELC Journal
1979. Vol.II No.2.
- Ellis, R. Classroom Second Language Development 1984.
Pergamon.
- Ellis, R. Understanding Second Language Acquisition. 1985
OUP
ESP Journal Teacher.- Training, Vol.2. No.1.
1983. Pergamon.

- ETIC Archives Report on the M.A. Programme In Teaching ESP at Mosul University, 1982.
- Evans, G, O'Neill, T.,
Snow, P & Weller, R. Crescent English Course, 1977. Teachers' Book 8
.1982. OUP.
- Pupils' Books 1,2,3,4,5,6,7 and 8
 - Teachers' Books 1,2,3,4,5,6,7 and 8 OUP
- Fanning, P. and Swales J. Review of English in Basic Medical Science
by Maclean, J. (1975) ESPMENA No. 319 1975:76
- Fanning, P. Review of Nucleus : Biology 1976.
ESPMENA No.7. 1977
- Ferguson, N. & O'Riley, M. English for International Banking, 1978.
Evans
- Finocchiaro, M & Brumfit, C. The Functional-Notional Approach, 1983. OUP
- Flowerdew, J. Spoken Discourse and Three Types of Activity,
Proceedings of the First National Symposium on
Language Teaching, Kuwait University, May 1985
Kuwait.
- Fortune, A. Making Courses in Science and Technology More
Relevant to The Needs of Students. ESP,
Houlden, S. (ed) 1977 Modern English Publications
- Fry, T.F. Computer Appreciation, 1975, Newnes, Butterworths
- Gauntlet, J.O. Teaching English as A Foreign Language 1966
Macmillan & Co. Ltd. London.
- Greenall, G.M. The ESP Teacher : A Negative View in ELT 112
The ESP Teacher, 1981. The British Council,
London.
- Greenall, G.M. Recognising Discourse Features, English for
Academic and Technical Purposes. Selinker,
Tarone & Hanzeli (eds) 1981, Newbury House.
- Gregg, K. Krashen's Monitor and Occam's Razor. Applied
Linguistics 5. 1984
- Grellet, F. Developing Reading Skills, 1981. Cambridge
University Press.
- Greenwood, Learners and Factors in Syllabus or Course
Design - The Teaching of English As an
International Language Abbot, G & Wingard, P
(eds) 1981. Collins.

- Gumperz, J.J. & Hymes D. Directions in Sociolinguistics, Holt Rinehart and Winston, New York.
- Hajjaj, A.H. The Nature and Understanding of the Term Function and Its Application to English for Special Purposes With Special Reference to Physics Texts Used in Kuwait University, Unpublished Ph.D Thesis, August, 1979. Lancaster University.
- Halliday, M.A.K. et al. The Linguistic Science and Language Teaching, 1964. Longman.
- Halliday, M.A.K. Explorations in The Functions of Language 1973. Edward Arnold.
- Halliday, M.A.K. Learning How To Mean, 1975, Edward Arnold.
- Halliday, & Hasan Cohesion In English, 1976, Longman.
- Harris, Z. Papers in Structural And Transformational Linguistics, 1970. Reidel- Holland.
- Hatch, E.V. Second Language Acquisition : A Book of Readings, 1978. Rowley, Mass, Newbury House.
- Hatch, E & Long, M. Discourse Analysis in Second Language Acquisition Larsen-Freeman (ed.), 1980. Newbury House Publishers Inc.
- Herbolitch, K. Box Kites, Episodes in ESP, Swales, J. (ed) 1985. Pergamon.
- Hoey, M. On the Surface of Discourse, 1983. Allen & Unwin
- Holden, S. (ed) English for Specific Purposes, (ed) 1977, Modern English Publications.
- Holliday, A. Research Into Classroom Culture as a Necessary Input to Syllabus Design, ESP In The Arab World, Swales & Mustafa (eds) 1984. LSU, Aston University, Birmingham. The United Kingdom.
- Hopkins, A. Review of Episodes in ESP. Swales, J. (ed) ELT Vol. 40 No.3. 1986.
- Hutchinson, T. & Waters, A. Creativity in ESP. Vol. 5. Lancaster Practical Papers, 1983. Pergamon.
- Hutchinson, T. & Waters, A. ESP At the Crossroads, Swales J. (ed) 1985. Pergamon.
- Hymes, D. Language in Education, 1980. Center for Applied Linguistics, Ethnolinguistic Essays.

- James, K. et al. Listening Comprehension and Note-Taking Course, 1979, Collins,
- Johns, T.F. & Dudley-Evans, An Experiment in Team-Teaching of Overseas Postgraduate Students of Transportation and Plant Biology in ELT 106 Team-Teaching in ESP The British Council, Also in Swales, J (ed) Episodes in ESP, 1985, Pergamon.
- Jones, K. & Mountford, A. Some Dimensions of the Design of ESP Service English Programmes. The ESP 2nd Regional Conference, Isfahan, held 1977, Isfahan University, 1979, Isfahan, Iran.
- Johnson, K. Communicative Syllabus Design and Methodology, 1982 Pergamon.
- Johnson, K & Morrow, K. Communication In The Classroom. 1981, Longman.
- KAAU ESP Project - The Structure of Lectures, Final Report, University of Birmingham, The United Kingdom.
- Kachru, B. Model of English for The Third World, TESOL Quarterly Vol. 10. No.2. 1976.
- KBI Statute KBI 1981 PAAET, Kuwait.
- KBI Syllabus for The Teaching Of English at The Commercial Institute, 1975. Ministry of Education, Kuwait.
- Kennedy, C. Fundamental Problems in ESP, ELT Document 106 Team-Teaching in ESP, 1980. The British Council
- Kennedy, C. & Bolitho, R. English for Specific Purposes, 1984. Macmillan
- Kerr, L. English for Special Purposes, English for Specific Purposes, Holden, S. (ed) 1977, Modern English Publications.
- Kharma, N.N. Motivation and The Young Foreign Language Learner ELT Journal, 1977, Vol. 31. Jan.
- King, P. The CSE Programme for Medical Students at KAAU and The Science or Language Dilemma, English for Specific Purposes. ELT Document 101, The British Council.
- Kneller, G.F. Introduction to the Philosophy of Education, 1972. John Wiley & Sons.
- Krashen, S. Second Language Acquisition and Second Language Learning 1981. Pergamon.

- Krashen, S. Principle and Practice in Second Language Acquisition, 1982. Pergamon.
- Labov, W. Sociolinguistic Patterns, 1972, Basil Blackwell. Oxford.
- Language Teaching Proceedings of The First National Symposium May, 1985, Kuwait University, Kuwait, (3 volumes).
- Larsen-Freeman Discourse Analysis in Second Language Acquisition 1980, Newbury House Publishers Inc.
- Larsen-Freeman Techniques and Principles In Language Teaching OUP.
- Lee, W.R. Technical, Technological and Scientific English Strevens, (ed) Teaching English as An International Language, 1980, Pergamon.
- Lee, W.R. Some Points About Authenticity, 1982. WORLD LANGUAGE ENGLISH Vol.2. No.1.
- Leech, G & Svartvik, A Communicative Grammar of English, 1975. Longman.
- Leontiev, A.A. Psychology and The Language Learning Process 1981. Pergamon Institute of English, Oxford.
- Lewis, M. & Hill, J. Practical Techniques for Language Teaching 1985. Language Teaching Publications.
- Littlewood, W. Communicative Language Teaching, 1981. CUP
- Lyons, J. Introduction to Theoretical Linguistics, 1968 CUP.
- Mackay, R. Developing Reading Curriculum, English for Academic and Technical Purposes, Selinker, Tarone, & Hanzeli (eds) 1981 Newbury
- Mackay, R & Bousquet, M. Languages for Specific Purposes, Mackay, R & Palmer J.P. (eds) 1981, Newbury House
- Mackay, R & Mountford, A. (eds) English for Specific Purposes, 1978, Longman.
- Mackay, R & Palmer, J.D. Languages for Specific Purposes 1981, Newbury House.
- Maclean, J. English in Basic Medical Science, Focus, 1975 Oxford.
- McDonough, J. ESP in Perspective 1984. Collins ELT

- Morrow, K. Authentic Texts and ESP, Holden, S.(ed) English Specific Purposes, 1977, Modern English Publications.
- Morrow, K. Techniques of Evaluation for A Notional Syllabus. RSA 1977.
- Mountford, A. Discourse Analysis and the Simplification of Reading Materials for English for Specific Purposes. Unpublished M.Litt Thesis 1975. University of Edinburgh. The United Kingdom.
- Mukattash, L. Problematic Areas in English Syntax for Jordanian Students, University of Jordan, Amman, 1975. ELT Journal, 1976.
- Mullen, N & Brown, P.C. English for Computer Science 1983. OUP
- Munby, J. Communicative Syllabus Design 1978 CIP
- Murphy, F.D. Communication and Correction in The Classroom ELT Journal Vol.40. No.2. 1986.
- Nash, R. Classroom Observed 1973, Routledge, & Kegan Pau
- Nuttal, C. Teaching Reading Skills in A Foreign Language. 1982. Heinemann FLT
- O'Neill, Kernall Lessons Intermediate 1971. Eurocentre & Longman.
- O'Neill, R Kernel Lessons Plus 1973. Eurocentre & Longman.
- O'Neill, R. The Limits of Functional Notional Syllabuses. or My Guineapig Died with Its Legs Crossed, Holden, S.(ed) English for Specific Purposes 1977, Modern English Publications.
- O'Riley, M. et.al Talking Business 1975, Macmillan
- Palmer, F.R. Semantics: An Outline 1981, Penguin
- Palmer, J.D. Discourse Analysis, Languages for Specific Purposes, Mackay, R & Palmer, J.D. (eds). 1981, Newbury House.
- Palmer, J.D. & Mackay, R. Languages for Specific Purposes, 1981. Newbury House.
- Phillips, M.K. & Shettlesworth C.L. How To ARM Your Students - ELT 101, 1978, also in Swales, J. Episodes In ESP, 1985, Pergamon.
- Phillips, M.K. Towards a Theory of LSP Methodology, Mackay, R. & Palmer, J.D. (eds) 1981 Languages for Specific Purposes. Newbury House.

- Poythress, V.C. A Framework For Discourse Analysis, The Components of a Discourse from A Tagmemic Viewpoint. 1982. Semiotica Vol.38 3/4
- Quirk, R. The Use of English, 1962, Longman.
- Quirk, R. et al A Grammar of Contemporary English 1972, Longman.
- Richards, J. Error Analysis, 1974. Longman.
- Richerich, & Chancerel Identifying The Needs of Adults Learning A Foreign Language, Council for The Cultural Co-operation of The Council of Europe, 1980. Strassbourg.
- Rivers, W.& Temperly, M. A Practical Guide to The Teaching of English. 1978. OUP
- Rivers, W. Teaching Foreign Language Skills, 1981. Chicago University Press.
- Rivers, W. Communicating Naturally In A Second Language, 1983. CUP
- Robinson, H.A. Teaching Reading and Study Strategies, Allen & Bacon Inc.
- Robinson, P. English for Specific Purposes. 1980. Pergamon.
- Robinson, P. The Helpful ESP Teacher in ELT Document 112 The ESP Teacher 1981, The British Council.
- Robinson, P. Computer Programming (1971) Special English Series.
- Robinson P. & Humby, E. Computers (1971) Special English Series
- Roulet, E. Linguistic Theory Linguistic Description and Language Teaching, 1975. Longman.
- Sawwan, M.K. The Teaching of English As A Foreign Language to Secondary School Arab Students in Kuwait Unpublished Ph.D Thesis, 1984, University College, Cardiff, The United Kingdom.
- Schutz, N.W. & Derwig, B.L. The Problem of Needs Assessment in English for Specific Purposes, Some Theoretical and Practical Considerations, Mackay & Palmer (eds) 1981. Languages For Specific Purposes. Newbury House.
- Scott, H. & Scott, J. ESP and Rubic's Cube - ESP in The Arab World Swales, J. & Mustafa, H. (eds) 1984. LSU Aston University, Birmingham. The United Kingdom
- de Schiffirin, R.S. et al English in Action, 1969 Longman.

- Searle, J. Speech Acts, 1969, CUP
- Sharma, A. Guiding the Learning In A Self-Directed Learning Program : The Teacher As Facilitator and Manager. CAAL Vol.2. No.2. 1980.
- Sidewell, D. Teaching Languages In Today's Schools, Smith,D.G. (ed) CILT, 1981.
- Sinclair, J. McH & Coulthard, Towards An Analysis of Discourse,1975 OUP
M.
- Sinclair, J. McH & Brazil,D. Teacher Talk 1982, OUP
- Skeham, P. In The ESP Teacher ELT Document 112, 1981, The British Council, London.
- Slobin, D.I. Psycholinguistics 1979, Scott, Foyesman & Co.
- Smith, L. English As An International Auxiliary Language 1976 RELC Journal Vol.7. No.2.
- Special English Series 1971, English for Computer Programming, Strevens, (ed)
- Stern, H.H. Fundamental Concepts of Language Teaching 1980, Pergamon
- Strevens, P. New Orientations in The Teaching of English 1977, OUP
- Strevens, P. Teaching English As International Language 1980, Pergamon.
- Strevens, P. Teaching Languages in Today's Schools 1981 CILT
- Stubbs, M. Discourse Analysis 1983 Blackwell, Oxford.
- Swales, J. ESP in The Arab World, English for Specific Purposes, Holden, S. (ed) Modern English 1977 Publications.
- Swales, J. Leading the ESP Teacher to The Literature in The ESP Teacher ELT Document 112 The British Council, London.
- Swales, J. Aspects of Article Introduction LSU, Aston University, Birmingham. The United Kingdom.
- Swales, J & Mustafa, H. (eds) ESP In The Arab World 1984, LSU Aston University. The United Kingdom.
- Swales, J. (ed) Episodes in ESP, 1985. Pergamon.
- Tawfiq, A.S. A Communicative ESP Reading Skills Course for Students of the Faculty of Medicine, Iraq. A Case Study, ESP In The Arab World, Swales, J & Mustafa, H.(eds) LSU,Aston University, Birmingham The United Kingdom.

- Thomas, J.L. & Loring, R.M. (eds) Motivating Children and Young Adults to Read, 1977, ORYX Press, Mansell, London.
- Torbe, M. Communication Skills in Employment and The Young School Leaver, English Communication Skills And The Need of People in Industry. CRAC Publication, Hobson Press, Cambridge. United Kingdom.
- Trim, J.L. Preface to Richterich, R and Chancerel, J.L. Identifying The Needs of Adults Learning A Foreign Language, 1980, Pergamon.
- Trudgill, P. Sociolinguistics, An Introduction, 1974. Pelican
- Urquhart, A.H. (1978) Comprehension: The Discourse Analysis View: Meaning in Discourse.
- Van Dalen, D Understanding Educational Research 1979, McGraw Hill.
- Van EK The Threshold Level For Modern Language Learning In Schools, 1977, Longman
- Van EK The Threshold Level, The Communicative Approach To Language Teaching, 1979, OUP Brumfit & Johnson (eds)
- Van Dijk Text and Context , 1979, Longman.
- Walker, C. Reading Development and Extension, 1974. Ward Lock Educational.
- Ward, J. The Teacher, The Student, The Classroom and The Communication Activities Vol. XXII No.3.
- Waters, A. (ed) Issues in ESP 1983 Pergamon. Vol.5. Lancaster Practical Papers in English Language Teaching.
- Welkowitz, J. et al Introducing Statistics For the Behavioural Sciences, 1976 The Academic Press.
- Widdowson, H.G. Teaching Language As Communication, 1978, OUP.
- Widdowson, H.G. Explorations in Applied Linguistics, 1979, OUP.
- Widdowson, H.G. English for Specific Purposes: Criteria for Course Design in English for Academic and Technical Purposes. Selinker, Tarone & Hanzeli (eds) 1981 Newbury House.
- Widdowson, H.G. Learning Purpose and Language Use, 1983. OUP
- Widdowson, H.G. Explorations In Applied Linguistics.2. 1984 OUP
- Wilkins, D.A. Linguistics in Language Teaching, 1972. Edward Arnold.

- Wilkins, D.A. Notional Syllabuses 1976, OUP
- Williams, R. The Potential Benefits to The ESP Profession from Greater Awareness and Practices in L1 Communication Skills Learning. ELT 112 The ESP Teacher, 1981. The British Council.
- Wingard, P. & Thompson L. Some Verb Forms and Functions In Some Medical Texts, 1976-1977 ESPMENA Bulletin.6.
- Winter, E.O. Fundamentals of Information Structure, Mimeo, 1976. Hatfield Polytechnic, Birmingham. The United Kingdom.
- Wragg, E. Oates, J. & Gump, P. E201 Block 11 Classroom Interaction, 1976. Open University.
- Yalden, J. The Communicative Syllabus, Evolution, Design and Implementation, 1983. Pergamon.
- Ziahosseiny, S.M. & Mountford. A. (eds) English for Special Purposes, ESP Second Regional Conference, Isfahan University, Isfahan, 1979. Iran.

APPENDIX A

Syllabus for the Teaching of English
at the Commercial Institute, 1975

Introduction

This syllabus is built on the following assumptions:

- (1) Most entrants must have passed the General Secondary School Certificate Examination but a few would have passed the Commercial Secondary School Certificate Examination.
- (2) A placement test should be conducted for dividing entrants into (at least) two levels: A - level could take the first of the four courses (101) at the rate of four hours a week while B - level (the weaker group) could take the same course at the rate of 6 hours a week.
- (3) Classes should consist of not more than 15 - 20 students.

General Objectives

- (1) The first two (101 and 102) of the four courses should be mainly concerned with activating the entrants' basic command of the fundamentals of English. The contents of the two courses especially the latter (102) should be coloured with commercial language.
- (2) The remaining two courses (103 and 104) should be mainly concerned with preparing the students to perform competently in such situations they are liable to meet with both in their specialised (commercial) studies and (later) in their jobs.

Organisation of Courses:

For the first three courses (101, 102 and 103), accountancy, secretarial practice and insurance, the four skills - listening comprehension, speaking, reading and writing should be given equal weight. For the fourth course (104), computer science, the main interest will be concerned with Listening, Comprehension and reading in the specialised field of study.

Specific Aims:

The First Course 101

- (a) To give students the chance of revising (or) learning properly the fundamentals of English.
- (b) To give students a mastery of the language they will need in order to function properly in the remaining three courses (102, 103 and 104).
- (c) To stimulate in the students an interest in reading and (to some extent) in writing.

For convenience the content of the course can be split under the headings below (i.e. structures and functions) but the division is however artificial and it is the teacher's task to make the students see and learn the inter-relationship between them.

A. List of Structures

- Verbs and verb patterns
- Time and Tense
- Adjectives, Nouns, Pronouns and Articles
- Adverbials, adverbial particles, adjectives and adverbs identified in form etc.
- Participles, gerunds and infinitives
- Transformation e.g. negative, interrogation, passive.
- Co-ordination
- Subordination
- Kind of sentences
- Modification

(For further detail see Appendix I)

B. Skills and Functions:

(i) Listening and Understanding

- to understand questions/answers/social formulae of conversation (greetings, welcoming, apologies, thanking leave-taking, invitation, request, suggestion, complaint etc/instruction/information/statement/argument/explanation/.....)

- to draw conclusion
- to follow logic
- to differentiate fact from opinion.
- to discern attitude/suggestion/intention/preference/assumption/justification.
- to understand speaker's attitude (polite, rude)
- to understand speaker's reaction (pleased, astonished)

(ii) Speaking:

- to use appropriate special formulae (greetings, apologies, thanking, leave-taking, invitation, excuses, requests, suggestions, compliments, introduction, welcoming, promising, praising, blaming)
- to ask/answer questions
- to agree/disagree
- to express opinion/intention/choice/purpose/plan/preference/approval/disapproval/.....
- to instruct/direct
- to summarise
- to generalise

(iii) Reading

- to identify facts/information/definition
- to understand instruction/suggestion/explanation/classification/comparison/contrast/directions/.....
- to guess meaning from context
- to discern writers' choice/purpose/plan/claim
- to understand formation of words: affixation/compounding..
- to draw conclusion
- to use (English/English or bilingual) Dictionaries.

(iv) Writing:

- to use appropriate punctuation/notation/spelling/capitalisation/abbreviations.
- to select facts /sequence/ordering/.....
- to summarise/classify/categorise
- to describe/compare/contrast/.....
- to answer questions
- to define
- to invite
- to express approval/disapproval
- to take (objective and essay type) examinations.

(2) The Second Course(102)

- (a) To consolidate the skills of the first course. (See lists of structures and functions above).
- (b) To use the structures mastered in the first course to convey the functions (appropriate to the field of commercial studies in general) in a more advanced and sophisticated level.
- (c) To establish a more advanced link between general English and commercial literature in general

A. List of Structures:

- See the list for 101 above
- See Appendix I for the specific structures to be covered in this course.

B. Skills and Functions:

The same as those mentioned in the first course (101) but for this second course they should be taught at a more sophisticated level.

(3) The Third Course (103)

- (a) To consolidate the skills (see lists of structures and functions above) of the first two courses (101 and 102)
- (b) To use the structures mastered in the first two courses to convey the functions appropriate to the field of commercial studies in general.
- (c) To introduce the students to specific writings appropriate to all fields of specialisations.

As it is the case with 101 and 102, the division into structures and functions is for convenience only; students by now should be able to use one structure for conveying more than one function and also to convey the same function through different structures.

A. List of Functions:

i. Listening and understanding

ii. Speaking

Functions mentioned for 101 and 102 should be kept and developed.

iii. Reading:

- to understand: advice/recommendation/exemplification/convention of arrangement, technical terms, language of advertisement.
- to discern writer's preference, obligation, implications.
- to gain information from charts/timetables/telegrams.
- to understand how to use equipment/monetary regulations.
- to understand foot notes/tables/graphs.

iv. Writing:

- to make enquiries, replies, quotation
- to prepare tender (voluntary), offers, invoicing, insurance contracts and accounts.
- to state sequence of relationship.
- to draw conclusion

(4) The Fourth Course (104)

The main interest of the course, for each of the four specialisations should be a concentration on the application of the structures and functions of the first three courses (101, 102 and 103). Therefore, no attempt has been made to provide either lists of structures or functions. However, the following areas of interest should be emphasised according to their relevance to the four fields of specialisations. However, for the computer science special interest should be given to listening and reading comprehension.

(i) Insurance

- Life assurance
- Life insurance
- Marine Insurance
- Aviation Insurance
- Fire Insurance
- Accident Insurance

Appendix I

List of Basic Structures for 101 and 102

(a) Course 101

- Present simple and position of time adverbs
- Present continuous
- Simple past tense (regular and irregular verbs)
- Counts and uncounts (unit and main words)
- Some, any, a few, a little
- Past tense with 'ago' and questions with 'How long ago'.
- Adjectives and Adverbs
- Comparison of adverbs
- Going to do
- Requests and offers and take, get, bring, show, some-more, something.
- Present Perfect with 'since' and 'for'.
- Have been doing/have just done/haven't done yet/had better done

(b) Course 102

- Past continuous and past simple
- Simple future used in requests, offers and of- 'must' & 'can'
- Present perfect and 'just'
(+ preview of contrast with simple past)
- Present perfect and past simple
- Frequent gerund construction
- Future simple with 'if' or 'when' and present simple clauses.
- Common pattern with verb + him/her/etc. + infinitive with/without 'to'.
- Future in the past
- Past perfect
- Conditional sentence
- Passive Voice in present and past
- Reported Speech
- Past conditional

Appendix II

Recommended Text Books and References

Course 101

a. Textbooks

	Title	Author	Publisher	Remarks
(i)	Kernel Lessons Intermediate	O'Neil et al	Longman 1972	- Upto end of Lesson 12. - Complete set: Teacher's Book, Student's Book, Test Books, Tapescript and tapes. - For A-level & B-level (for B-level in conjunction with No.2. below).
(ii)	First Things First	L.Alexander	Longman	- For B-level in conjunction with No. 1 above
(iii)	English in Situations	O'Neill	Longman 1971	For outstanding students (Never used)

b. Additional Commercial materials (appropriate standard) chosen by teachers (see Reading list for 201 and 202 and list of General Reference Books and materials)

Course 102

a. Textbooks

(i)	Kernel Lessons Intermediate	O'Neill	Longman 1972	- From lesson 13 up to the end of the book - Complete set: Teacher's Book, Student's Book, Test Books, Tapescript and tapes.
(ii)	English in Situations	O'Neill	Longman 1971	For all students (Never used)

b. Additional Commercial materials (appropriate standard) chosen by teachers. (See Reading List for 103 and 104 and list of General Reference Books and materials).

Appendix IV
Hardware and Software

1. Two 30 booth A/A/R Language Laboratories, one for the boys' and the other for the girls' Institute. Specification can be prepared by the Audio-Visual aids Department of the Ministry of Education.
2. Red Tapes required for the two labs.(approx. 500, 7 inch tapes).
- 3 Super-dynamic for master-tapes.
3. Casettee tape-recorders 6 W output (one for every teacher)
4. T.D.K. Superdynamic 60 m Cassette tapes (approx. 500).
5. 2 reel-to-Casette and Casette-to-casette transport and duplicating machines. (These machines can be purchased according to specifications laid down by the A.V.A. Dept. or the said Dept. can carry out the transfer and duplicating operations required by the Institute.
6. 16mm cine-projector and screen.
7. Slide and strip projectors (two units)
8. Rear projection screen (two units)
9. Overhead projector (two units)
10. Flannel Board (two units)
11. 16mm Cine-films
 - (a) The Belcrest Story (B.B.C.)
 - (b) Other films on commerce and business to be purchased or borrowed from.A.V.A. Dept. if available
12. English typewriter (two units)
13. Stencil Duplicating Machine (two units)

EMPLOYERS

QUESTIONNAIRE - 1

Dear Chairman/General Manager/Proprietor/Director/Head of Department

The research I am doing, including this questionnaire, interviews and other observations as tools of research, will be submitted to the Arts Education Department of Warwick University in candidacy for a Ph.D. degree. I am studying various skills which are presumed to operate in the language-teaching process so as to determine and design the sort of material that will meet the needs of KBI students in general, and computer science students in particular.

Learning English for Specific Purposes — ESP — has become a necessity for the many people working in business, industry, and for those studying academic or technical subjects. However, this sort of Teaching-Learning process should be handled in the proper and most beneficial manner. To do this, I am asking you to fill in this questionnaire with sincerity and accuracy. In this way you will help lay the right and useful basis for courses to be devised and designed for particular learners or would-be officials who, if we are successful in laying them the right basis, will produce the best results at home, study, office and through their careers.

Answering this with seriousness would help a great deal. The answers will be confidential and will be used only for research interest.

Thanks for your co-operation.

I.A. Al-Attili (Ph.D. Candidate)

Arts Education Department,
Warwick University, England

I. PERSONAL

- 1. Name
- 2. Age Sex
- 3. Nationality
- 4. Education (degree and/or certificate held/expected)
- 5. Name of institution you work for:
- Company
- Firm
- Establishment
- Corporation
- Authority
- Bank
- 6. Number of branches /Departments/Units/Sections.....
- 7. Legal Status
- 8. Number of employees
- 9. Duties and Responsibilities
-
- 10. Which branch/Department/Unit/Section are you responsible for:

II ENGLISH LANGUAGE SKILLS AND LEVELS OF PROFICIENCY REQUIRED BY OFFICIALS,

GRADUATES

Please put X where required or applicable:

- 11. Are your employees required to use English

Yes	Often	Sometimes	No
-----	-------	-----------	----

- 12. How should the official's level of understanding spoken English be:

A. Excellent	B. Very Good	C. Satisfactory
--------------	--------------	-----------------

 - A Understands everything spoken.
 - B Understands almost everything spoken.
 - C Understands but needs to assimilate what is spoken.

13. How should his speaking skill be?

- A. Excellent ...
- B. Very good ...
- C. Satisfactory ...

14. How should the reading skill be?

- A. Excellent ...
- B. Very good ...
- C. Satisfactory ...

15. How should the writing skill be?

- A. Excellent ...
- B. Very good ...
- C. Satisfactory ...

16. Should proficiency in receptive skill^s and productive skills be equal?

Yes No

17. If your answer to the previous question was 'No', how would you rank the four skills?

- 1
- 2
- 3
- 4

III TASKS TO BE ACCOMPLISHED IN ENGLISH

18. The official is to use his receptive understanding skill with

Always Often Sometimes Never

- a. his boss
- b. his colleague
- c. his subordinate
- d. his client

19. The official is to use spoken English when:

Always Often Sometimes Never

- a. receiving/giving reports
- b. asking for/giving information
- c. asking for/giving explanations/
instructions
- d. holding meetings

20. The official is to read English when:

Always Often Sometimes Never

- a. taking instructions/circulars
- b. handling correspondence/mail
(reading)
- c. issuing instructions and holding
meetings/reading leaflets
- d. directing transactions
- e. handling orders

21. The official is to be familiar with:

Always Often Sometimes Never

- a. certain terms necessary for his job
- b. idioms and acronyms related to his
job
- c. figures, tables, charts & diagrams
- d. proper channelling of certain
transactions

IV IN-SERVICE TRAINING

22. What do you think of your officials training in English at K.B.I.; has it been sufficient to meet the needs the job demands?

Yes No In Some Cases

23. Does/did he/she need further training in English?

Yes No In Some Cases

24. If your answer to the previous question was 'Yes', what language skills and activities does/did he/she need to be trained in?

- a. Equally in the four skills.
- b. In some of them - mention number

Yes No Listening Speaking Reading Writing

25. How would you rank his/her need for in-service training in the four skills?

- 1 -
- 2 -
- 3 -
- 4 -

26. Does he/she need regular training to cope with up-to-date techniques? Yes No

27. Did he/she need in-service training before he/she started his /her job?

Yes No

28. Are other texts in a Language other than Arabic recommended?

If yes, please specify.

Yes

In

No

29. Do you think your officials could gain anything from knowing a foreign language? If yes, what benefits?

Yes

- 1.
- 2.
- 3.

No

30. How would you describe the usefulness of English for a well-qualified professional in Computing?

Very Useful

Useful

Not Very Useful

Not Necessary

V GENERAL

Overall Standard of Efficiency of KBI Graduates You Opt for:

- | | | |
|--|-----|----|
| 31. a - Completely understands and properly responds to spoken English | Yes | No |
| b - Communicates efficiently in spoken English | Yes | No |
| c - Reads and understands efficiently written English | Yes | No |
| d - Writes accurately and to the point in English. | Yes | No |
| 32. a - Partially understands and responds to spoken English. | Yes | No |
| b - Communicates satisfactorily in spoken English. | Yes | No |
| c - Reads and satisfactorily understands written English. | Yes | No |
| d - Writes highly communicative English. | Yes | No |

33. Certain areas or skills to be given more emphasis.

- 1
- 2
- 3
- 4

34. Would you like to add anything else? (Please use the next page if necessary.)

- A -
- B -
- C -
- D -
- E -

QUESTIONNAIRE - 2

Dear Head of Department, Professor, Assistant Professor, Lecturer, Teacher,

The research I am doing, including this questionnaire, interviews and other observations as tools of research, will be submitted to the Arts Education Department of Warwick University in candidacy for a Ph.D. degree. I am studying various skills which are presumed to operate in the language-teaching process so as to determine and design the sort of material that will meet the needs of KBI students in general, and computer science students in particular.

Learning English for Specific Purposes — ESP — has become a necessity for the many people working in business, industry, and for those studying academic or technical subjects. However, this sort of Teaching-Learning process should be handled in the proper and most beneficial manner. To do this, I am asking you to fill in this questionnaire with sincerity and accuracy. In this way you will help lay the right and useful basis for courses to be devised and designed for particular learners or would-be officials who, if we are successful in laying them the right basis, will produce the best results at home, study, office and through their careers.

Answering this with seriousness would help a great deal. The answers will be confidential and will be used only for research interest.

Thanks for your co-operation.

I.A. Al-Attili (Ph.D. Candidate)

Arts Education Department,
Warwick University, England

I. PERSONAL

- 1. Name
- 2. Age Sex
- 3. Nationality
- 4. Education (degree and/or certificate held/expected)
- 5. Name of institution you work for
- Department Units/Sections
- 6. Number of Units/Sections/branches.....
- 7. Legal status
- 8. Duties and responsibilities
-
- 9. Which branch/Department/Unit/Section are you responsible for:.....

II. ENGLISH LANGUAGE SKILLS AND LEVELS OF PROFICIENCY REQUIRED BY GRADUATES

Please put X where required or applicable.

10. Are your students required to use English?

Yes Often Sometimes No

11. How should the students(graduates) level of understanding spoken English be?

A. Excellent B. Very Good C. Satisfactory

- A. Understands everything spoken.
- B. Understands almost everything spoken.
- C. Understands but needs to assimilate what is spoken.

12. How should his speaking skill be?

- A. Excellent ...
- B. Very good ...
- C. Satisfactory ...

13. How should his reading skill be?

- A. Excellent ...
- B. Very good ...
- C. Satisfactory ...

14. How should the writing skill be?

- A. Excellent ...
- B. Very good ...
- C. Satisfactory ...

15. Should proficiency in receptive skills and productive skills be equal?

Yes No

16. If your answer to the previous question was 'No', how would you rank the four skills?

- 1
- 2
- 3
- 4

III. TASKS TO BE ACCOMPLISHED IN ENGLISH

17. The student is to use his receptive understanding skill with

Always Often Sometimes Never

- a. his boss/teacher
- b. his colleague
- c. his subordinate
- d. his client

18. The student is to use spoken English when

- | | | | | |
|--|--------|-------|-----------|-------|
| | Always | Often | Sometimes | Never |
| a. receiving/giving reports | | | | |
| b. asking for/giving information | | | | |
| c. asking for/giving explanations/
instructions | | | | |
| d. holding meetings | | | | |

19. The student is to read English when

- | | | | | |
|--|--------|-------|-----------|-------|
| | Always | Often | Sometimes | Never |
| a. taking instructions/circulars | | | | |
| b. handling correspondence/mail
(reading) | | | | |
| c. issuing instructions and holding
meetings/reading leaflets | | | | |
| d. directing transactions | | | | |
| e. handling orders | | | | |

20. The student is to be familiar with:

- | | | | | |
|---|--------|-------|-----------|-------|
| | Always | Often | Sometimes | Never |
| a. certain terms necessary for
his job/study | | | | |
| b. idioms and acronyms related
to his future job | | | | |
| c. figures, tables, charts &
diagrams | | | | |
| d. proper channelling of certain
transactions | | | | |

IV. IN-SERVICE TRAINING

21. What do you think of your students' training in English at K.B.I.; has it been sufficient to meet the needs the job demands?

- | | | |
|-----|----|---------------|
| Yes | No | In Some Cases |
|-----|----|---------------|

22. Does/did he/she need further training in English?

- | | | |
|-----|----|---------------|
| Yes | No | In Some Cases |
|-----|----|---------------|

23. If your answer to the previous question was 'Yes', what language skills and activities does/did he/she need to be trained in?

a. Equally in the four skills b. In some of them - mention number

Yes No Listening Speaking Reading Writing

24. How would you rank his/her need for in-service training in the four skills?

- 1
- 2
- 3
- 4

25. Does he/she need regular training to cope with up-to-date techniques? Yes No

26. Did he/she need in-service training before ^{she} he started his/her job? Yes No

27. Are texts in a language other than Arabic recommended reading materials for the course? If yes, please specify.

Yes In No

28. Do you think your students could gain anything from knowing a foreign language? If yes, what benefits?

Yes 1. No

2.

3.

29. What do you recommend your students to read for Computer Science courses? Please specify 2 to 4 books.

- 1
- 2
- 3
- 4

30. How would you describe the usefulness of English for a graduate to be a well-qualified professional in Computing?

Very Useful Useful Not Very Useful Not Necessary

V. GENERAL

Overall Standard of Efficiency of KBI Graduates You Opt for:

31. a. Completely understands and properly responds to spoken English. Yes No

b. Communicates efficiently in spoken English. Yes No

c. Reads and understands efficiently written English. Yes No

d. Writes accurately and to the point in English. Yes No

32. a. Partially understands and responds to spoken English. Yes No

b. Communicates satisfactorily in spoken English. Yes No

c. Reads and satisfactorily understands written English. Yes No

d. Writes highly communicative English. Yes No

33. Certain areas or skills to be given more emphasis.

- 1
- 2
- 3
- 4

34. Would you like to add anything else? (Please use the next page if necessary).

- A -
- B -
- C -
- D -
- E -

GRADUATES

QUESTIONNAIRE — 3

Dear Graduate, Student,

The research I am doing, including this questionnaire, interviews and other observations as tools of research, will be submitted to the Arts Education Department of Warwick University in candidacy for a Ph.D. degree. I am studying various skills which are presumed to operate in the language-teaching process so as to determine and design the sort of material that will meet the needs of KBI students in general, and computer science students in particular.

Learning English for Specific Purposes — ESP — has become a necessity for the many people working in business, industry, and for those studying academic or technical subjects. However, this sort of Teaching-Learning process should be handled in the proper and most beneficial manner. To do this, I am asking you to fill in this questionnaire with sincerity and accuracy. In this way you will help lay the right and useful basis for courses to be devised and designed for particular learners or would-be officials who, if we are successful in laying them the right basis, will produce the best results at home, study, office and through their careers.

Answering this with seriousness would help a great deal. The answers will be confidential and will be used only for research interest.

Thanks for your co-operation.

I.A. Al-Attili (Ph.D. Candidate)

Arts Education Department,
Warwick University, England

I. PERSONAL

- 1. Name
- 2. Age Sex
- 3. Nationality
- 4. Education (degree and/or certificate held/expected)
- 5. Name of institution
- Department
- 6. Number of branches /Departments/Sections.....
- 7. Legal status
- 8. Duties and Responsibilities (if employed)
-
- 9. Which branch/Department/Unit/Section are you responsible for (if employed)...

II. ENGLISH LANGUAGE SKILLS AND LEVELS OF PROFICIENCY REQUIRED BY GRADUATES OR PROSPECTIVE GRADUATES

Please put X where required or applicable:

- 10. Are you required to use English

Yes	Often	Sometimes	No
-----	-------	-----------	----

- 11. How should the student's (graduate's) level of understanding spoken English be:

A. Excellent	B. Very Good	C. Satisfactory
--------------	--------------	-----------------

 - A Understands everything spoken.
 - B Understands almost everything spoken.
 - C Understands but needs to assimilate what is spoken.

- 12. How should his speaking skill be?

A. Excellent	...
B. Very good	...
C. Satisfactory	...

13. How should the reading skill be?

- A. Excellent ...
- B. Very good ...
- C. Satisfactory ...

14. How should the writing skill be?

- A. Excellent ...
- B. Very good ...
- C. Satisfactory ...

15. Should proficiency in receptive skills and productive skills be equal?

Yes No

16. If your answer to the previous question was 'No', how would you rank the four skills?

- 1
- 2
- 3
- 4

III. TASKS TO BE ACCOMPLISHED IN ENGLISH

17. The student/graduate is to use his receptive understanding skill with

Always Often Sometimes Never

- a his boss/teacher
- b his colleague
- c his subordinate
- d his client

18. The student/graduate is to use spoken English when:

Always Often Sometimes Never

- a receiving/giving reports
- b asking for/giving information
- c asking for/giving explanations/
instructions
- d holding meetings

19. The student/graduate is to read English when

Always Often Sometimes Never

- a taking instructions/circulars
- b handling correspondence/mail
(reading) •
- c issuing instructions and holding
meetings/reading leaflets
- d directing transactions
- e handling orders

20. The student/graduate is to be familiar with:

Always Often Sometimes Never

- a certain terms necessary for his
job/study
- b idioms and acronyms related to
his future job
- c figures, tables, charts &
diagrams
- d proper channelling of certain
transactions

IV. IN-SERVICE TRAINING

21. What do you think of your training in English at K.B.I.; has it been sufficient to meet the needs the job demands?

Yes No In Some Cases

22. Do/did you need further training in English?

Yes No In Some Cases

23. If your answer to the previous question was 'Yes', what language skills and activities do/did you need to be trained in?

a Equally in the four skills b In some of them - mention number
Yes No Listening Speaking Reading Writing

24. How would you rank your need for in-service training in the four skills?

1 -
2 -
3 -
4 -

25. Do you need regular training to cope with up-to-date techniques? Yes No

26. Did you need in-service training before you started your job? Yes No

27. Are texts in a language other than Arabic recommended reading materials for the course? If yes, please specify.

Yes In No

28. Do you think you could gain anything from knowing a foreign language? If yes, what benefits?

Yes No

29. What texts are/were recommended for computer science courses, etc.? Please specify 1 to 4 books.

1
2
3
4

30. How would you describe the usefulness of English for a graduate to be a well-qualified professional in Computing?

Very Useful Useful Not Very Useful Not Necessary

V. GENERAL

Overall Standard of Efficiency of KBI Graduates You Opt for:

31. a - Completely understands and properly responds to spoken English Yes No

b - Communicates efficiently in spoken English Yes No

c - Reads and understands efficiently written English Yes No

d - Writes accurately and to the point in English Yes No

32. a - Partially understands and responds to spoken English Yes No

b - Communicates satisfactorily in spoken English Yes No

c - Reads and satisfactorily understands written English Yes No

d - Writes highly communicative English Yes No

33. Certain areas or skills to be given more emphasis.

1

2

3

4

34. Would you like to add anything else? (Please use the next page if necessary.)

A -

B -

C -

D -

E -

COMPUTER LECTURE

by

MR. SARTAWI

Good afternoon ladies! (Let us welcome Mr. Al-Attili). We's doing something today because it is one of his requirement(s) He is coming today eh and he's joining us for his Ph.D - Doctorate Program about the computer science and how we teach computer science in English in KBI (Check whether recording is OK or not). So we welcome Mr. Ismat as our guest today. We (will) hope he will enjoy being with us and we will enjoy being with him.
- Thank you very much -

5

Let us start today about...Let us talk today a little bit about the basic element(s) of the computer

10

A computer - to define a computer many people...get confused about the word computer and many people think that the computer is a brain or it is something...eh strange or something like that. Many people think the computer can think by itself; and they think the computer can do things; computers can do things that we can't.

15

First of all we have to define the word computer in order to clarify the confusion about it. A computer is a machine capable of processing data to produce information. So we have to stop a little bit about some words here: 'A machine' and the word 'processing' and the word 'data' and the word 'information!'. So let us write the definition and then we can clarify each word.

20

(Writes on the board) A computer is a machine capable of processing data to produce information. So the word .. first word is a 'machine' and 'processing' 'data' and 'information'. The word machine - here - so the computer is completely clarified by these words. The computer is a machine; it is not anything else. It is completely like a refrigerator or it is like a television or any kind of machine run by - the - electricity. So a computer is completely like any machine, run by the electricity. For it is not a brain or something strange or something confusing - it is just a machine run by the electricity.

25

30

If we go further with the definition we can see capable of processing data to produce information....So we have to define eh the-- the word eh...'processing' first eh! The word 'processing' when you process something, it means you convert this thing from some phase to another or from some fact to another. So the word processing here, it means, it is manipulating or 'manipulation'...;

35

something, to another thing. So we can em...accept this definition 'processing' means 'manipulating'. If you process something, it means you manipulate something, convert it ... from some fact to another fact. So a computer is a machine capable of processing data to produce information. So converting data, a computer is a machine capable of converting data; from what? converting the information from data. So we have data - we have data. 40 45

If we draw this diagram (Draws a diagram on the board Input Data - processing - output information)'data' here, We have a computer here. Then we will get information. So a computer is a machine which can manipulate data to produce information. So if we have the processing element which is a computer, so we can process data to produce information. So we have two new terms here : 'data' and information'. We hear about these two terms a lot in computer books and computer courses and...even in the fields different than the computer. 50 55

We hear about the word 'data' and the word 'information'. Let us define the word 'data'. 'Data' eh we can define it as: 'data' is a 'raw material' gathered from one or more sources. So it is a raw material; raw material (writing on the board and repeating raw material). So 'data' is just raw material that we cannot build any kind of conclusion; we cannot have any kind of decision on these data. Data is just raw material...which, if you give this raw material to anybody, they will not understand anything. It is just elements; it un understandable; not -- meaningful, nobody can build decesion or conclusion about these kind of data. 60 65

So 'data' if we..it is just like what?... if you have some kind of vegetables, meat and this kind of thing, you can't eat these things raw, you have to cook these things in order to produce something eatable, tasty, smelling. This (is) done by the computer....so if you cook your vegetables and meat and this and this to produce your nice meal.. This is called 'information' The nice meal is called 'information'. It is completely tasty, smelling and nice to eat. Here also, we have the same thing 'data' is just 'raw material'; you can't have conclusion. You can't have decision on these things. If you manipulate these data by the computer, you can get information. So the 'information' is...we can define it in order to clarify everything 'information' is the processed data that has a meaningful; that has meaning to the people receiving it. Let's write the definition. The processed data that has a meaning to the people receiving it. So 'data' it is completely - (different) has a meaningful, has no meaning. It is a meaningful information. Sorry! Information has a meaningful result. It is completely understandable. It is completely eh built to get decision or to give decision. So information is the processed data that has a meaning to the people receiving it. The data is raw material gathered from one or more sources. So if we leave the computer a little bit and think of some examples that can clarify the meaning of the data and information. 70 75 80 85 90

Let us have an example like that. Suppose an instructor of the Computer Department at KBI has three tests for a students' class...consists of 30 students. Each test score 100 maximum 100. So we have three tests; test 1, test 2, test 3 and we have 30 students. This data, test 1, test 2, test 3 and the name of the student; these are called data. So here the name of the student; just we write here. Ali test 1

95

Ali 90,35 and 60
Muhammad 80,75 and 95
and so on.

100

We have students. From this; now these, what I wrote on the board is nothing but data. If we look at Ali 90,35,60 Muhammad 80,75,95. These things ddoesnt mean anything to the registration office. I give these data to them. They don't know, they don't care about my grade or about test 1, test 2, test 3. They care about who is getting A, this is what they care about, who is getting b, who is getting C and so on.

105

So I have, as a computer instructor, let us say these stedents are in my calss. I have to manipulate these data. I have to convert these data from data to information in order to get a meaningful, the.....in order to get the meaningful results. So I have to convert this data into information. What should I do? I have to find the average of these 3 scores.

110

Score 1, Score 2, Score 3 or
test 1, test 2, test 3

115

Find the average of them. So 90 + 35 + 60 add them and divide by 3 I get the first score. Then 80, 75 95 add them and divide by 3 I get the 2nd score. I get score No.1, score No.2 which is if it is between 80 & 90; it will be A...'b', if it is above 90, it will be A.and so on. So at the end I will write Ali has C, Muhammed has, let's say d, Sami, let's say C, Mariam (get) d, Fatma (get) F and so on. So now Ali got B, Muhammed got C and so on. Let us say. These are called information. So from these;

120

raw material; which is test 1, test 2, test 3. We processed these data. We processed it; we processed it to what? to produce information. So 'information' has meaning to the Registration Office, to the....any people, any people, concerned about grading or something like that might understand these things.

125

So let's go back to the definition and clarify everything now. 'Data' is raw material, gathered from one or more sources. Here the data gathered by making test 1, Test 2, Test 3. So what I did is test you (the class) all first test. I made the 2nd test for you. I made the 3rd test for you. I gathered my data from you. You are the source. You the students are the source. I can't give my score; just say Mariam will get 95. Aisha will get 60 and so on. Here the data; is completely real data and it is....each data represent the students clearly. So when I said OK. My data now..this data doesn't have any meaning to me, doesn't have any meaning to the student, doesn't have any meaning to the registration office; doesn't have any

130

135

140

meaning to the eh. eh you also. Every one acquiring this data; anyone will use it. OK what I am going to get? Am I B student? Am I A student? Am I C student? If I process these data, everyone of you will know these results. So after I processed the data; adding the 3 scores together, divided by 3 and give the result of these scores. This is called information. So I get a list of information. Ali get B, Muhammed get B get Sami C, Mariam get D and Fatma and so on. So this is data. This is (pointing on blackboard) information. I convert data from unmeaningful things to something meaningful, eh..understandable. What I did is convert these things; This is done completely by hand. This is called manual processing (repeated). 145

The manipulation....done completely manually. No machine entered in this kind of manipulation. This manipulation...done completely by human being....writing...by hands. This is called 'Manual Processing'. 155

Now if we go back to the definition 'Computer is a machine capable of processing data to produce information', so the computer has the ability to produce information from data, So a computer is capable of processing data; like what I did completely here converting the 3 scores into what? into the average of these 3 scores. A computer has the ability to do this. So there is a similarity between the human being and the computers. Both of them have the ability to produce information from data. They have the ability (repeated) to processing data to produce information OK? (pointing to students) Is the word 'information'...and 'data'..and 'computer' is completely clear? Any questions so far? (no response) This denotes students have understood and have no questions to ask. 160 165 170

'Data' is raw material. If we process data, we will get information, 'Information': It is the 'processed data'; that has a meaningful or that has a meaning to the people receiving it; not any people, people who ...concerned about it; they understand it. OK? And the computer is a machine just like any machines it is capable of processing data to produce information, It is like completely the human being, the human being has the ability to produce data from information. Any questions so far? Is the word...or these terms 'data' and 'information' clear to you? Any question?....OK. Well I hope you understand these kinds of things because it kind of new....Let's step a little bit farther to a new...term; this term is called EDP. You will hear a lot of these if you write to any computer magazine or if you write any advertisement about... in computers asking about EDP manager or EDP something. 175 180 185

The word EDP. EDP Electronic Data Processing. (Repeats) Let us clarify these things. This example on the board, I have 3 scores and you know we just... What we did here we just processed these scores to produce information. This processing is done manually. So it is not EDP; this is manual data processing. So what is the EDP? EDP; it is the processing that is done by the computer. Instead of using the human being in this processing, if I use 190

the computer in processing, what I do is just put these data in a file and write a program; very very small program in any kind of language. Basic (language) Fortran (language) and COBOL (language) and write a program and run this program. So the computer will process this data that was in the file; it is called a student file. I have a student file here; it is somewhere in the disk and I write a programme here called a student program. If I run this program on this data, I'll get the same result that has (been) done by manual...or that has (been) done by human being; manually. So EDP; it is..nothing but the processing that is not done by human being...So if anybody ask/s you: (1) what is EDP? the term EDP? It is Electronic Data Processing? (2) What is computer? It is machine capable of processing data to produce information. But here if we look at the definition when I gave this example you heard me say, we have to write a program (1) program and here I am going to put the (2) data on the (3) disk. So I have two things program and data. Look here I am going to write a program so the human factor is very important because the human factor is the main-most important element in data processing. Without my program here this data will never be processed. And this program; it should be very very accurate. And this program is nothing but a complete instruction to the computer that tell/s the computer what to do. So if we really if we want to say what the computer is. The computer is nothing but a slave, you know you, the human being, are the master. You have to tell the computer what to do. You are the master and the computer is the slave. After you go the, to write your BASIC program how you are going to go and just write your program and the results will be produced to you..And any kind of programs; you write it and the computer, just a slave; you write rubbish, you get rubbish. You write true things you will get right things. So do not think that the computer will just do things for us and we are just sitting and relaxing, we have to... put our force; We have to think, the computer can't think at all. The computer is completely like a slave and you program this slave to do this & this & this and this and if any kind of instruction is wrong, because you did not think well, all the processing will be rubbish. This is what they call it in Data Processing 'Gigo' 'Gigo' the term 'Gigo' stands for 'Garbage in'... 'Garbage out'. It means that if you give garbage into the computer, you will get it garbage. That means if you don't know how to process the data, you will get it garbage. If you...OK, write a very nice very...program and your data entry people...they made some kind of mistakes in entering some kind of data, you will not get in the accurate information... Program is OK but you have a problem here in the data...so we have...if we want to go farther in the computer courses, we have to check about these kinds of things. We have to make validation programs about the data. We have to ...We have to.... We have many people revising these things in computer departments in order to get the right information process... Very hard to discover the right things if we....

OK. I can stop here and just leave...a couple of minutes for you to ask questions about the data and term data, term information, term computer. These are very important terms and I

hope...I suppose that everyone of you should know these terms clearly because it is very important and we have to build a lot according to these things. We have to build many things, many kinds of facts about these terms. So if you have any questions don't feel shy please go ahead and ask. OK? Any questions so far about these terms?

250

So if there is no question on this kind of things, now we have ...Let's step a little further to, in the Basic elements of the computer.

255

So this machine we have to study this machine a little bit and we are not going to go on deep to this thing because we have to study this in 102, course 102 here we have to go farther, here we have this programming course and I give some elements of the computer we are not going to go deep into these things.

260

Now let us say what is the elements of the computer. Now let us see what is...the basic elements of the computer. Let us draw the basic element of the computer and then see. What this is! The computer in essence is divided into; any computer system really...is divided into four parts: The most important part is called CPU. You will hear this a lot in computer. CPU stands for Central Processing Unit, Central Processing Unit. This is in the section where...things will be processed; data will be processed here. So this is the first part. The 2nd part is called Input Unit. The 3rd part is called Output Unit. So we have Input Unit, Output Unit and we will have this section here or unit here called backing storage. (repeats) This unit is...if you don't want it, it is OK. But most of computer systems who have data who have to save this kind of data, I think should be there. But if you have a small computer in your room and want just to write small program and then leave these programs. This will this program be kept in the memory and then if you turn electricity off, everything will be gone. So we have input unit, CPU....We have I/O Unit, then call it I/OUnit. So in fact we have just 3 units: I/O unit. And the function of this unit is nothing but getting the data to the CPU and getting the information or the result from the CPU. So we called it I/O unit. Abbreviation for input, output unit; I/O Unit.

265

270

275

280

So this is the first section I/O unit. The second section is CPU. As we said it stands for what? Central Processing Unit, Central Processing Unit. This is the most valuable, the most important element of the computer system; is called CPU. Central Processing Unit. In this unit data...processed to produce information and the last section is backing storage section (repeats) B.S.S. Or they call it they call it, sometimes 'Auxiliary Storage' (repeats). But it is common by backing storage section. In this section we have to store our data or our information. So... ..So here, we have to talk a little bit about each section a little. Then we go farther to each section.

285

290

295

I/O unit. The function of I/O unit is to get the data to the computer; to the CPU in order to process this kind of data. I/O unit; it stands for input/output unit. The function of this unit is to give the data into the computer and to get the information or the result from the computer. CPU stands for central processing unit and the function of this unit is nothing but process the data to produce information. So as we said this is the most important element of the computer system. This is the most valuable section. You pay money a lot to this section. Here you buy computer. This is the most valuable part. And the last section is 'Auxiliary Storage', 'backing storage' as we said backing storage. Named by backing storage a lot in computers. Books call it 'Backing Storage' is a unit in which you store your information or your data. OK? 300 305

So, we have to talk a little bit about the most important part of the computer which is called CPU and see its parts. CPU is divided into 3 parts or three units. First unit is called ALU which stands for Arithmetic, Logic Unit. The 2nd part is called CU or Control Unit. Control Unit and the third part is called memory. So we have 3 parts; ALU No.1 ALU No.1. Two control Unit, CU. Three memory. OK. 310 315

Now we have to talk a little bit about the first part and see. What stands for and why we need it. ALU stands for Arithmetic Logic Unit. From the meaning we can the function of this unit: ALU. This is the most important part of the CPU; this is the most valuable part of the CPU. In this part or in this section; the data ...processed here, so the most important part of the computer system is the CPU and the most important part of CPU is ALU Arithmetic Logic Unit. In this section ...Data...(is) processed here. Any data; it should come to the ALU to be processed. So the function of ALU is processing data. But if you look at the name, it is Arithmetic Logic Unit. So we have really in computer ...in computer, electronic data processing in computer processing, we have two kinds of operation(s) arithmetic operation and logical operation Arithmetic operation is like what? Addition, multiplication, division, subtraction and so on. Arithmetic operation ei... logical operation..it is like and you have two statements; true and true will be true statements. True and false...it will be a false statement. This is called and operation or operation. If we have true and false, it will be true. False and false.. it will be false and so on. We have a list of arithmetic operation and logical operation and any statement we are going to write in the computer; it should be one of these kinds of operations either Arithmetic operation or logical operation. 320 325 330 335

So when we are going to write out programs, all the instruction should be either arithmetic operation or logical operation and in ALU the arithmetic or logical operation will be processed here. So the function of ALU is processing the arithmetic and logical operations. Control unit CU from its name, we can see, it is nothing but ..ah... it is function is like a traffic controller just you know letting the eh..it's just like a traffic controller... it is just...co-ordinating the flow of the data between the 340 345

computer sections. So it is like a traffic light. And the last part is the memory. In the memory here. ..It is like the computer memory...the human memory. The human memory if you put something in the human memory, it just memorising these things; it just (keep/s) it. If your memory is good. We say this man ...his memory is good. He might be very stupid, but his memory is good. So if you said this memory here is nothing but just to store the information; to send it to AIJ...So the function of the memory here is just storing information or the data. It is like a human being just, store. So if your memory is good so you are storing the data or information. 350 355

OK.now. I think now time is over and we have to stop here and we will have next topic. It will be, we'll take that tomorrow, next topic ...it will be the procedures of solving any computer problems and it might be written in your assignment; that I gave to you and you might read it and prepare that for the next lecture. 360

APPENDIX D2

COMPUTER SCIENCE LECTURE

by

MR. ADNAN ALMUKBIL

I introduce you to Mr. AL-Attili, a colleague, lecturer in the English Department. He is requested that ...we are going to record the today lecture....em..so welcome him again for joining us... and we start...(cleaning the board).

As usual em before the lecture em. (comment in Arabic by a students)...em in the last lecture we were speaking about magnetic (tape) tape (a student adds)....em. There is three main use for the magnetic tape. Anybody can tell.. what are these uses of magnetic tape?

5

We use magnetic tape for 3 main purposes. Anyone can tell what they are? Muneer. Answer:...used as an output device and input device and the...(she stops)... and used as secondary memory (added by the teacher -. the student together).

10

First one as Input.../output device (yes) - and third one as secondary memory.

15

Is the secondary memory connected to the CPU or not?. Khadeeja...
Khadeeja - No...

Teacher - Secondary memory is not connected to the CPU. It is out-side the CPU. For that reason the secondary storage is called external storage and the main memory is called the internal memory or internal storage.

20

A student is participating in the answer.

Now...Anybody can explain the magnetic tape... without looking at the notes? The physical - physical description first. What is it..the magnetic tape? Maysoon - Mona Maarafi...(Comment/ Answer):(I was absent, I can't answer!)

25

Teacher - Which lecture were you absent in? (Arabic)

Student - Last lecture.(in Arabic)

30

Teacher - This is not the last lecture. This is the one before the last....Sara (another student)(no response)....Come on!...Adeeba (another student).

Adeeba - It is a magnetic tape....aha.ha.. 35
Teacher - (talks along with her). It is a long tape
covered with a magnetic material from one of
its sides, but...and the width of the tape...
usually between ($\frac{1}{4}$ - 1) inches...and the length
is not fixed (by a student)...Ya....OK. 40

Question - How data are recorded on a magnetic tape?
Yes...again. Eiman (a student).

Student's Data are recorded on a magnetic tape on
answer - spots on the tape on tracks. (aha aha the tape...)

*Between brackets is a comment by the teacher. 45

The tape consist(s) of seven and eight but actually in today's
tapes maybe more. So they maybe eight or nine tracks. So the
data are recorded on the tape on these spots which is em...magnetic
spots. In fact each one of these spots represents a bit. The
characters A,B,C,D whatever - each one for instance the A; 50
using the EBCEDIC Code equal to what? Anybody can remember?
remember the schemes, the EBCEDIC? the A in EBCEDIC (is) equal
to what? .. (.responses)... equal to C1 in the EBCEDIC code right
and say the 9 equal to F1. on the tape the A using the EBCEDIC
code is going to be represented or recorded as follows: That is 55
the C9 is equal to 11000001. Here the C on each one and here
is (counts one to eight) on eight tracks; this is the C and
the one is going to be like that. The nine, F9; this is the F
right? This is the F and the nine which is 11111001 and this is
the nine. 60

At least one fact we have to remember = everything enters in
the computer, at the end, is going to change into binary, Which
is 0's and 1's O.K.? So using the EBCEDIC or ASCII code, the A
is going to be represented like this and the 9 is going to be
represented like this. 65

Of course these we cannot see, of course, these data on the
tape. It is all magnetic and very ..em. In fact it is not our
business to know how these data recorded. In this time, in this
hour; in this lecture. This maybe ...concerning the engineers 70
em but we are thinking, when we say that the A is recorded on
this we are speaking about em piece of an inch. As you remember
that...each inch of a tape . On each inch of a tape we can record
thousands of characters and thousands of bits and this is only
about sixteen or twenty bits. In each inch we can record another
thousand of these bits on a tape. 75

Looking to the picture of a tape. We say it consists of
tracks: eight or nine or 7 tracks. Of course if we are recording
in ASCII, the ASCII we have 7 bits, in ASCII instead of 8 we
have 7; is that right or not?, three for the digits and four
for the zone bits. One of the disadvantages of the or of using 80
the magnetic tape....what is it? One of the disadvantages of
using the magnetic tape, anybody can tell..what is it? Come on...

We said there are some features of the magnetic tape and there are as well some advantages....(voice of a student in background)
No, actually it may be one of these advantages or the features that is not eh one...tape... 85

Abeer - It is a sequential access device.

Teacher - Yeah, what does it mean?

Abeer - If anyone want it goes foot by foot from one to the other. 90

Teacher - Yeah, Thank you. It is known by the disadvantages of using the magnetic tape, it belongs to a group which (is) called the sequential access device. That is. If we are requested a certain data, supposing the data in this field, say 24 characters which is say at the middle or end of the tape. By sequential we mean we have to start from the beginning of the tape and shift to the end; until we reach the required data. And of course this time, matter of using time and of using some work, it is not advisable. Unlike the magnetic disk which is our lecture for today. 95 100

Magnetic disk and magnetic disk drive is our lecture for today which is exactly opposite the magnetic tape when it comes to the direct or sequential access. Disk or magnetic disk belong to the direct access devices. If we need any data, we can go directly into the data and we call it. Of course, we use the address for calling this data. Of course if one..can get the result of the magnetic tape in somehow it is like a cassette...recorder; right? There is certain songs in the middle and at the end you have to, example this recorder to press the forward...the forward until you reach the required song..(data) or recording or whatever. But in the disk, it is somehow like the album (Alustuwarat in Arabic) and you place it in the middle or in the end of the tape (Arabic explanation). That is the difference with operating systems when it comes to the operating systems; the magnetic disk is eh...em more important than the magnetic tape....(movement) shows the real disks and tapes. Erm. As indicated before, this lecture is going to be about the magnetic disk. Nisreen, what is it?... in the physical aspects; how we record data on the disk or how data are recorded on the disk and how can we read and write the data recorded on a certain disk? 105 110 115 120

So before speaking about the disk individually, we are going to speak about...the whole system: the magnetic disk, the magnetic disk unit and the magnetic disk drive. 125

So instead of giving each one, we are going to speak about all of them; all under one one heading and then we have to separate headings for the data representation and for read-and-write-data on certain disks. Eh. As can be seen. In this disk picture...is erm...You can see as the thin metal platter covered from both sides with a magnetic material (explains in Arabic)....obviously can be seen like an album....erm (explains in Arabic...metal covered on both sides with magnetic material) 130

(The) Disk unit, when we have disk unit consists of many boxes or drums....you have seen drums...aha..aha...like, with due respect, rubbish bins. (-points to a small one in the classroom) .. Haven't you gone to the Ministry of Planning? (repeated in Arabic) You see drums separated or distributed or these drums, they call it magnetic disk unit. Each one of these boxes; in each one of these boxes, there is a magnetic disk drive. Now we have magnetic disk unit and we have magnetic disk drive. In each one of these boxes; consists of magnetic disk drive, There is at least one disk, one disk and one of these....At least, some of the computer maybe have two, some of them ten, some of them twenty. Eh, It is very difficult to say how many disks we have in one disk drive...but at least one disk (one surface, at least, for storing information). At least one disk; could be ten or twenty disks. If there is more than one, these disks, as can be seen here, are connected with each other from the centre.(No from the centre) (these plates, flat plates) are connected with each other from the centre.. Now I have disk unit consisting of many boxes and I have...there is in each one of these, of course, at least one disk and there is another for the disk drive, they call it read-and-write head-Read-and-write heads like exactly an arms. Of course sticks can lean (In Arabic this means fixed from one direction and free from the other), and the other part exactly like this. It comes in between the disks (explained in Arabic) to do what? To read and write the information on a disk. This eh...the arms and the read-and-write heads and the disks; they call them Magnetic Disk Drive.

جاء

Now...say the main job for the...Magnetic Disk Drive, it is somehow like the magnetic tape drive...If you remember the magnetic tape drive we said there is a machine which is its main job is to read and write data recorded on a magnetic tape... but we have a reel and paper reel and the reel must pass through read-write head...exactly the same job for the magnetic disk drive except the mechanism in the magnetic disk drive is completely different than the mechanism at the magnetic tape drive. Of course,since we have read and write heads, we must have data. Otherwise what the necessity of read and write heads? Read and write...data.. Each one of these..(writes)...disks of course, this is, maybe start listening as...as like this. It is central. It consists of many parts; consists of many of course should be better. This supposed to be a circle (it is not precise....by the way) eh starts drawing. This supposed to be circle (drawing) (in Arabic).Data are recorded on this disk. Each one of these; they call it track. Exactly if you remember the tape; that is track. The track, the tape is long. But... with respect to the disk, it is circle; rounded. If you remember the Athletics field (in Arabic) exactly the same idea... This whole 400 yards is a circle. This if you can put it the core and there are the circle tracks around the field. OK (The data...where? .. is going to be stored on each of these (girls take part) tracks. The numbering of the tracks starts from 0 up to well, actually..it ranges...some of them 200, some of them 300 and some of them more or less just depending on the quantity of data we are going to store on these recordings. Right! Each

side of a disk, they call it surface. (in Arabic;Sath) This is a surface. A surface consists of many tracks and the data are recorded on these tracks. Of course, the data recorded here is unlike the tape, unlike the magnetic tape. It is going to be, for instance, we have the previous example, A9 which is equal to C1 and equal to F1 right! Where we are going to recover data on this disk, the data is going to be somehow like C...ups, yeah or that is A and the g is going to be, maybe 1111 and 1001 whereas the previous one it was like that 11000001 and 11111001 and obviously it can be seen that if you want to call or to request any data in this case (is) certainly easier than the other way (girl takes part). We just need to have the address of course, ad indicated before everything inside the external or the internal memory, memory, sorry?! must have an address. Yes exactly like any person. If you have the address, house number, street number, whatever city here the same. The address is track number, surface number and location. Once we know that, it is very easy to call this data or the data is stored on a magnetic disk. Because of that, it is called a direct access device. (in Arabic) (Because of this, they call it the direct access device. (Because I only) I know the location of the data (and its) address, (so I can go directly to) track 1, track 2, track 3, track 4 Whatever. But here it is very difficult, because each data or each character is recorded on many, many tracks. Each character, the A for instance, recorded on 8 or 9 nine tracks, depends on whether it is EBCEDIC or ASCII. Right? So it is very easy to cut. For that to reach it on the magnetic tape, we have to scan through until we reach the required data.

One may ask...is the quantity of data recorded on track, say 150 the same as the data recorded on track 1? Abeer?

Abeer - Yes
(a student)

Teacher - Very good. The answer is yes. Also the track, wider, outside track seems bigger and it is bigger indeed, but for data representation; for instance instead of writing the one like that, in the small track we are going to write it like this. Then amount or the quantity recorded on these tracks are the same. So we better write some of what we have been speaking about. ei .. shall I...just...Anything just signal...don't speak...

Disk is a thin metal platter covered on both sides with magnetic recording material. This belongs to the direct access devices. Anybody can tell....what does it mean? Direct Access Device...

Teacher - Come on, Adeeba.

Adeeba - When we want to require data, we directly read the part that the data is in it*.

Teacher - Very good! Very Good. Very Good. Sorry!

- Teacher - If we want to read and write information on a magnetic disk drive, only the first top and the last bottom surfaces ~~doesn't~~ or it won't include any data (It means this surface and the last one under the arms) Read-and-write heads cannot reach them. They are out of reach of the arms. Due to that, we cannot store any information or data and the same for the one beneath. We cannot store data and any of the rest, we can record any number of data. 285
- Student - Shall we write,.....copy them? 290
- Teacher - Yes , if you want. Anyway, we are going to speak about this in full detail, maybe, in the next session. 295
- Students - ...talk.....
- Teacher - laughs, well, I am sorry. Well carry on next lecture. And thank you again. .. Mr. (For Mr. Al-Attili); forgive my mispronunciation. 300

Appendix D 2nd
Course Title: Fundamentals of a computer system.
1st and 2nd term students

Topic "Magnetic Tape And Magnetic disk"

Revision of previous lecture (about magnetic Tape).

Question 1: What are the main uses of a magnetic Tape?

Answer 1: It is used as Input/output (I/O) device, and as secondary memory for storing data.

Question 2: Is the secondary memory connected to the central processing unit (CPU)?

Answer 2: No

Comment: Secondary memory is outside the CPU for that reason it is sometimes called external storage (memory) and main memory is called internal storage (memory).

Question 3: What is the physical description of a magnetic Tape?

Answer 3: It is long plastic tape covered with a magnetic material from one of its sides; its width is about $(\frac{1}{4} - 1)$ " ; the length not fixed could reach 3,600 feet.

Question 4: How data are recorded on a magnetic Tape?

Answer 4: Data recorded on (a) magnetic spots on Tracks.

Comment: The Tape consists of 7 or 8 Tracks. In today's Tape even more Tracks (can be found) Each data or character is recorded on a magnetic spot as shown below.

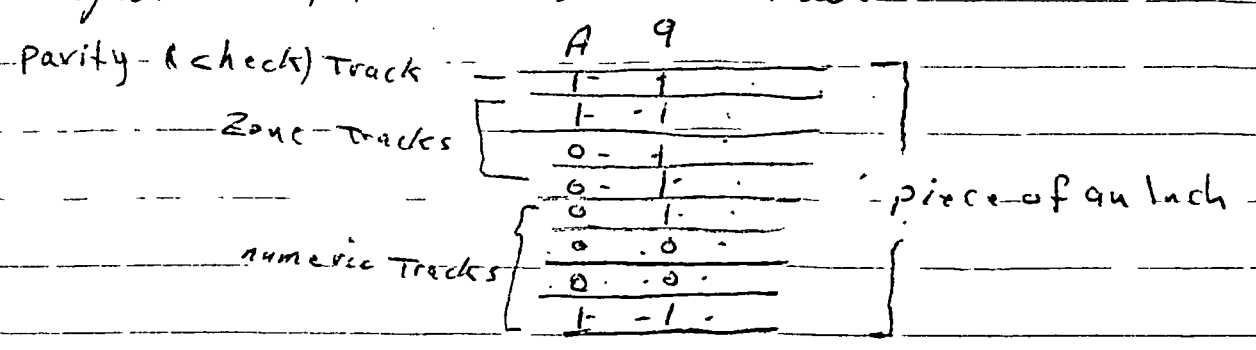

IF for example we are using EBCDIC code for representing data, and suppose A9 is recorded on Tape.

"in EBCDIC"

$$A9 = C1 F9$$

$$A = C1 = 11000001$$

$$9 = F9 = 11111001$$

on magnetic tape A9 is expected to be as above.

One fact we have to remember, Every thing enters the computer is changed into Binary, which contains only 0's and 1's.

Data recorded on magnetic Tape cannot be seen by naked eye since there are thousand of characters ^{that} can be recorded per inch of magnetic Tape.

In ASCII code usually there are 7 instead of 8 Tracks.

Question 5: Explain the main disadvantages of using a magnetic tape.

Answer 5: Tape is a sequential access device, that is, if a certain data are requested, all data prior to it must be read before reaching the required one.

Comment: Operating on tape in the above manner is time consuming and employs ^{takes} extra work to reach certain data unlike magnetic disk which is our lecture for today.

Magnetic Disk: One of the most important devices in storing huge amount of data, it is also used as Input/output (I/O) device.

Disks belong to the direct access devices; if any data is requested from a disk, we can call it directly once its address is known [some how magnetic tape resembles the recording cassette and magnetic disk the gramophone].

Disk: Is a thin metal platter covered from both sides with a magnetic material.

Disk unit: Consists of many boxes in each of these boxes there is at least one magnetic disk, the quantity [?] is varies if more than one, the number of disks are connected with each other from the center.

Disk drive: Consists of many arms fixed from one side and free from other side that contains read and write (R/W) Head. These R/W heads are inserted between disks to R/W data from disks.

Recording data on Magnetic disk :-

Disk is covered on both sides with a recording magnetic material; each side of a disk is called SURFACE; each surface consists of many circular Tracks, data are recorded on these Tracks [on Tape the Tracks are long but on disk they are rounded]. There are large number of Tracks on each surface. The outside numbered 0 and so on toward the center

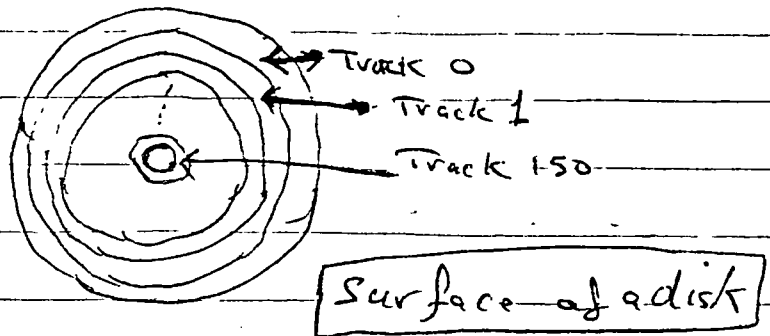

Data recorded on disk as below consider the previous example

A	9
1	1
1	1
6	1
0	1
0	1
2	0
3	3
1	1

Recording data

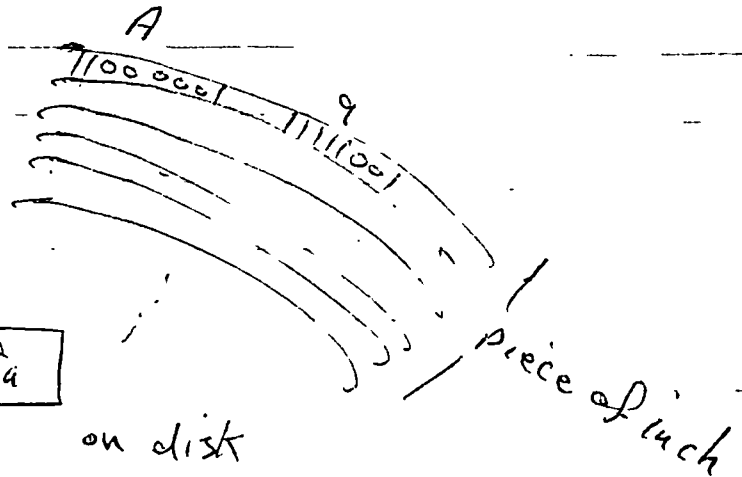

on Tape

As can be seen, it is easier to access certain data from a disk. Once its address is known it can be called directly [unlike the tape where certain data is distributed among many tracks].

The quantity of data on each track on the surface is the same (we can record the same amount of data on each track). Although the outside tracks look wider, the data in the inner tracks are written closely to each other.

R/W data from Disks

the device that

The magnetic disk drive is R/W data from disks.

R/W heads are inserted between disks in a certain mechanism. These disks are spinning in a certain speed, other wise it is not possible for R/W heads to reach all data on the surface of the disks. Data are recorded on all surfaces except the first top and the last bottom surface that R/W heads cannot reach.

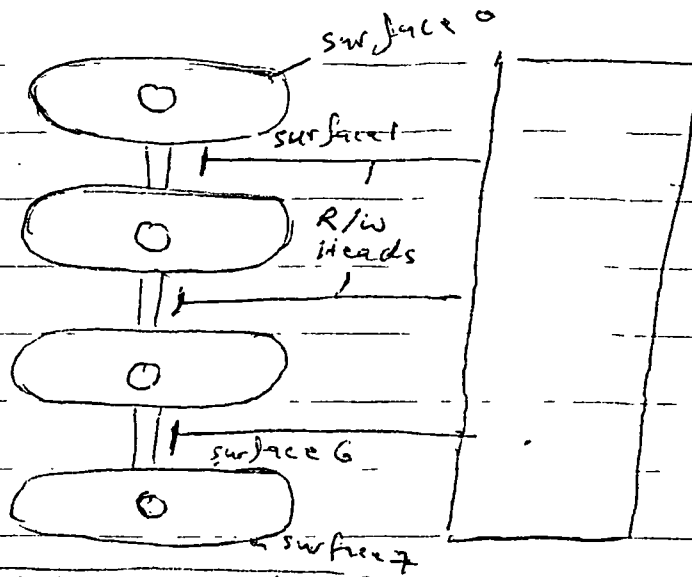

Magnetic disk drive
R/w data from magnetic disks

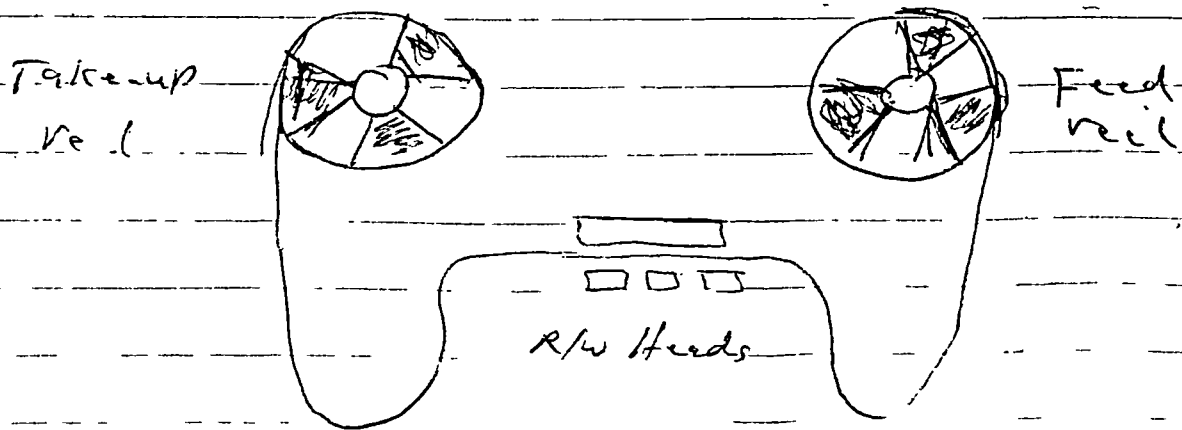

Magnetic Tape drive
R/w data from magnetic Tape

(Time Over)

To continue in next lecture

PERIPHERAL

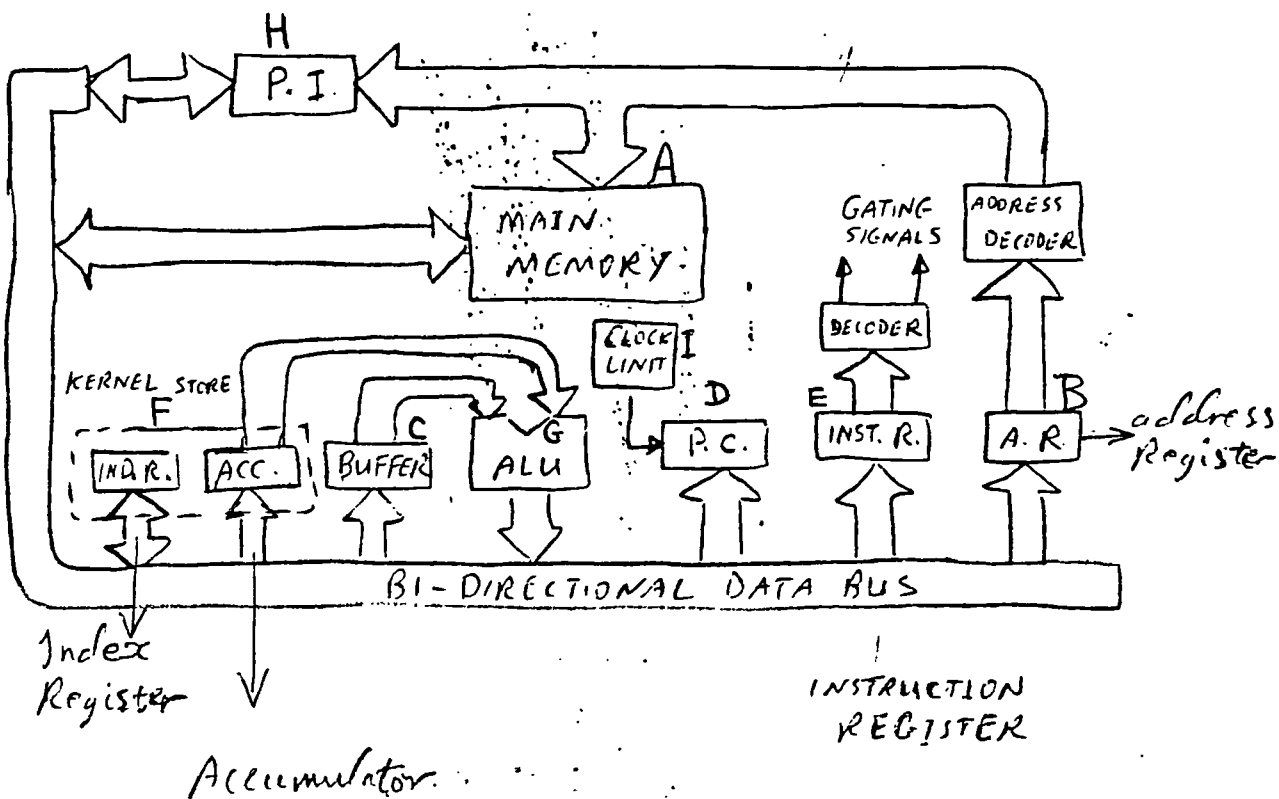

A HYPOTHETICAL COMPUTER

Register

A high-speed device capable of storing a specific amount of data or of storing intermittent results during processing.

From the above figure:

Computer consists of the following important units:

- A) A main memory. It retains several K of 16-bit words each of which may represent a single machine instruction, a signed integer or two 8-bit characters.

b) Address Register

to hold the address of a specified word in main memory.

c) A buffer (register) the function of which is to act as a general purpose data transfer register in which numbers can be stored to be added or subtracted from other numbers in the accumulator.

d) A program counter (PC) which enables the computer to proceed through a program from one instruction to the next.

e) An instruction register (I.R.) which holds the instruction currently to be obeyed. This register is connected to the function decoder in order that the bits which represent the desired function will produce appropriate signals to call into action those parts of the arithmetic unit necessary for executing the function.

f) Acc. and indirect register (kernel store).

These are the accumulator (ACC.), which is referenced in nearly all the available machine instructions and which is used to hold the result of an arithmetic or other operation, and the index register (IND. R), which has important uses in address modification and conditional transfers.

g) An arithmetic and logic unit (ALU) which is used to perform basic arithmetic operations and the various logical functions.

h) A peripheral interface (P.I.) which enables information into and out of the machine to be connected to a range of input and output devices, such as electric typewriters.

i) A clock unit which generates streams of precisely synchronized pulses and distributes them to various parts of the machine. These pulses are used to shift information from one register to another, to open and close gates at the right time and, in general, to provide the whole system with a kind of heart-beat.

Control Gates

by means of which the streams of bits may be directed to correct destinations. Such gating may be performed by means of AND-gates through which the information may or may not be allowed to pass.

The following figure shows how gating may be accomplished.

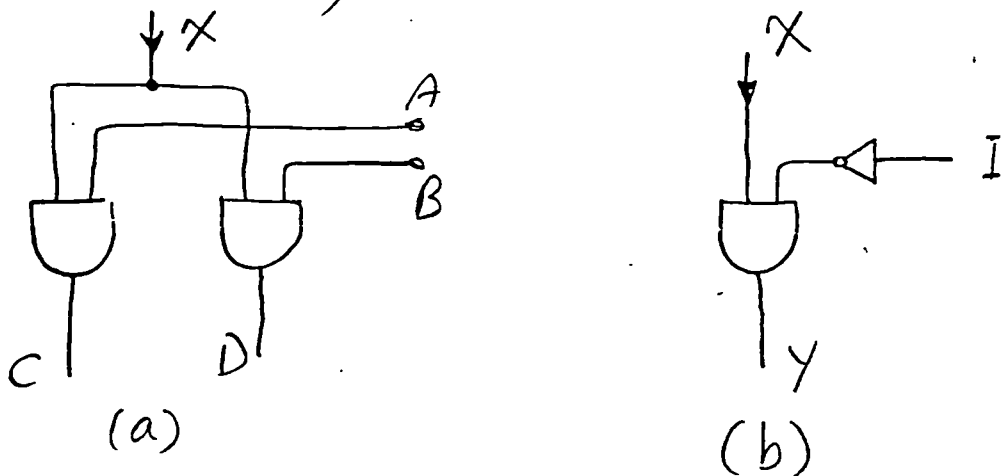

Gating Information

In (a) information may be diverted from the source X to either C or D. A logic 1 at A results in flow to C, while a 1 at B causes the information to be routed to D. Of course, if 1s are presented simultaneously at A and B, then the same bit pattern will appear at both C and D. In (b) a 1 at I acts as an inhibit signal which prevents information flow from X to Y.

The Data Bus.

This ...
 gating system for routing information between registers, main memory and the ALU. Only a single word may be on the highway at any one time, although several registers may have information simultaneously gated into them. The input and output devices are linked via the peripheral interface in the data bus also.

Any word in the machine is simply a set of 16 bits. This set may, however, be interpreted in a number of ways. First, a word may be used to represent a computer instruction, and secondarily, it may represent data such as numbers or characters.

Instruction Format.

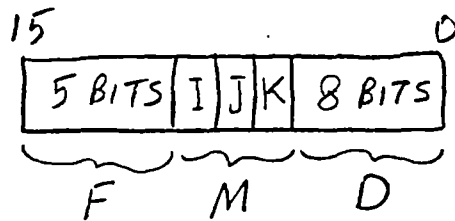

The left-most five bits constitute a function field, F, which may be used to specify a maximum of 32 different functions. These functions listed below together with a mnemonic - a group of 3 letters...

Appendix E

Computers and Their Uses in Kuwait

According to Deeson, E. (1983:7):

"A computer is a modern, general-purpose, high-speed, digital electronic, stored program data processor".

In the book from which this definition is taken, Eric Deeson envisages a readership of young people or adults wanting to learn about computers, then he thinks of parents who want to help their sons and daughters, then teachers in any kind of school or college as wanting to help their students. At the end of his short preface, he finds that he has about 157 different types of user, for whom he tried to cater.

Our section concerns Kuwait Business Institute and the different types of user for whom we try to cater form a formidable assembly, with international significance. ESP courses are obviously presented with a variety of language usage: both lexical items and syntactic structures are coined or re-shaped to meet new purposes. The language thus formed, as a tangent of the English taught to Kuwaiti students, has some sort of resemblance to language-theory as we have known it which becomes evident when we read such comments as: "a computer-language is a rapidly-developing thing" and "The BASIC you get on each micro is a unique dialect of the language. If you know one dialect, such as the BBC version, it is fairly easy to understand programs listed in any other. (Ibid:13)

One of the stated aims of learning in this field is : "to process information for the office, language laboratory or library". This could hardly be more pertinent to the work undertaken by the ESP teacher.

Computer Studies and Applications

The researcher now proceeds to outline some of the applications of the computer and the computer studies at KBI. As with Mr. Deeson, others are constantly being involved.

Speaking about computer science as a subject at KBI assumes that it is a specialism among many others: Business Administration, Accounting, Banking, Insurance, Materials Management, Co-operatives and Medical Secretaryship but it forms an integral part of each.

Computer Study

As a new invention in the modern world, it makes raids on the English language for its own purpose, using, to some extent, the descriptive terms with which we are familiar in language-study. This justifies the use of the terms 'Computer Science' and 'Computer Study'.

The Computer as a Tool

But the computer can also be seen as a tool, one that is easy to use (children use it successfully) modern and attractive in its format, fast. It is automatic and can be programmed. It does not become bored with a routine task, as a work-force easily may. It can minimise the time taken to do a task and is therefore economical; in a small space it has huge storage capacities. Its importance in communications, airline-guides and reservations, information systems and electronic data-processing come to mind as obvious beneficiaries.

Computers In Use

To detail some of the main uses made in the University of Kuwait would be to list admissions, record-keeping and time-tabling, research, estimating and planning for the future, testing and measurement, graduation requirements, typing and word-processing. All this is relevant to KBI where Computer Science is taught.

The Kuwait Institute for Scientific Research - KISR - exists as a separate Institution with its own independent range of researches but it too gives training in research methods to those who need it and so may be said to have students who can benefit from computer-learning, especially those on holidays and wanting to have training as a way of getting into the world of computers.

The Ministry of Planning which relies on such devices as sampling on public health by means of questionnaires and health research, census, and the study of social phenomena in order to draw up and carry out plans for the future looks to the computer for the storage and retrieval of its findings. In fact they seize every opportunity to help develop modern ways of living.

The Ministry of Communications is a very obvious user, granted its dependence on telephone calls, the computation of bills (especially telephone bills), telex, taping calls for answering services, the distribution of mail, coding, the exchange of documents and reservation of trunk calls, are all carried out through computers, if so required by users of their systems.

The Ministry of Public Health, as with the Ministry of Planning, uses the computer for research in illness, for patient-records and the registration of births and deaths. Processes such as scanning and the examination of food stuffs are computer-aided, also the calculation of budgets-services in preventive medicine, immunization, for example, employ the computer.

Perhaps the greatest range of varieties of English may be found in the list of demands made by the Ministry of Interior upon the computer resources. The Police Academy trains and teaches the Police Cadets. Among the many other special purposes of using computers, come election lists, general records, car registration, driving licences, records of expatriates, the details of visitors, their countries of origin together with work and residence permits. In catering for airport safety, the Ministry of Interior must make

all preparations through computer terminals. The calculations relevant to aeronautics; the timetables and visual display units are also used to provide information for citizens and travellers to and from Kuwaiti airports.

The Ministry of Education similarly has a computer centre dealing with budgeting and tenders, pupil-registration, students, employees, their salaries, promotions and allowances. Records of school-leavers and certificate holders are to be kept in storage for further reference. Recently computer science has been added to the curriculum for secondary schools.

For statements on the public life of Kuwait, the Ministry of Information is responsible for public records as on employees and production, informative programs on Kuwait radio and TV, matters of printing and copyright, the monitoring of programs and public announcements.

In a region where such services are of high importance, the Ministry of Electricity and Water deals with bills and records, the control of power stations and generators, as also with research on water desalination. And in trade transactions, The Ministry of Trade and Industry needs to record licences, import and export deals as well as to document research in industry, feasibility studies, and matters concerning metrics, banks, autobanks and insurances have very well utilized computers. They have been competing with one another to offer computerised services to their customers. Whilst the Ministry of Defence undertakes the documentation of conscription and enlistment together with records of the armed forces; on defence, surveillance systems, the charting of planes and naval vessels, also radar and research in these concerns, the Ministry is the responsible body.

In domestic matters: housing its surveying, planning and architecture, comes under the Ministry of Housing, as do applications for houses and the overall survey of types of houses available.

In dealings of the courts of law such as newly-enacted laws, disputes and commercial settlements, the Kuwait Gazette is used by the Ministry of Justice for formal and official announcements. On labour laws, the rights, duties and responsibilities of employers and employed, the Ministry of Social Affairs and Labour has the task of making public the legislation governing these statutes. It also undertakes the provision of work-permits for expatriates and records of labour disputes. On family welfare, it must document families in need of support and the provision of assistance given.

A new user of computer capacity that has recently come into being (1982-) is the Public Authority for Civil Information. This Authority has opened up new doors and created plentiful opportunities for KBI computer science graduates. Its working sphere incorporates information about the population of Kuwait. Besides this it files and stores records of all expatriates. Since its coming into being, KBI students have had their interests enhanced in computing due to some sort of job security being created for them through this Authority. Field training is also availed of, by students

ates

of KBI, on its premises. Even part-time jobs are there for those computer scientists that can afford it.

Within one region this multiplicity of concerns is served, as far as its business commitments go, by KBI and the varieties of English called for are extensive, let alone the computer language which now forms an important part of the programme of studies. The range is from the formal announcement of new laws down to simplified caption language on public-health notices and the correct use of application forms and recorded-delivery receipts. All these are taught within the Business Institute.

It may be thought that one aspect of the use of language within Computer Studies has been missed and that is the application of the new techniques of learning programmes but this has been recently catered for by The Authority for Applied Education and Training.